

Probabilistic Regulation for Inland Vessels Operating at Sea as an Alternative Hinterland Connection for Coastal Harbours

Marc Vantorre¹

Ghent University, Dept EA15, Maritime Technology Division, Ghent, Belgium

Katrien Eloot²

Ghent University, Dept EA15, Maritime Technology Division, Ghent, Belgium, and Flanders
Hydraulics Research, Antwerp, Belgium

Guillaume Delefortrie³

Flanders Hydraulics Research, Antwerp, Belgium

In 2007, the Belgian Federal Authorities issued a Royal Decree concerning “inland vessels that can also be utilised for non-international sea voyages”, allowing inland vessels to operate in coastal areas between the Belgian coastal harbours and the Belgian inland waterway network via the Western Scheldt. These new regulations have a unique character due to their probabilistic approach: among other requirements, a risk analysis must demonstrate that the probability of adverse events such as bottom slamming, overtaking of water on deck and ingress of water in open cargo holds is limited to an acceptable level. Several inland vessels (tankers, container vessels, car carriers) are nowadays operating according to this Decree in significant wave heights up to 1.90 m. Background is provided into these present regulations, with emphasis on the probabilistic aspects. A description is given of the methodology used for performing the required risk analyses. The effect of important parameters is discussed, both ship related (metacentric height, bilge keels) and wave climate dependent, and an overview of the ongoing research at Flanders Hydraulics Research and Ghent University on estuary container vessels is given.

Keywords: estuary traffic, inland vessels, hinterland connection, probabilistic approach.

1. Introduction

Hinterland connections are of major importance for a maritime port, as an increase of traffic and harbour activities is only possible if sufficient means are available to guarantee the flow of cargo between the port and the hinterland. Taking account of the high degree of congestion of the motorways, a sustainable growth of the traffic of the Belgian harbours implies that the majority of

¹ Technologiepark 904, B 9052 Gent, Belgium, T: +3292645555, E: marc.vantorre@ugent.be

² Berchemlei 115, B 2140 Antwerpen, Belgium, T: +3232246035, E: katrien.eloot@mow.vlaanderen.be

³ Berchemlei 115, B 2140 Antwerpen, Belgium, T: +3232246035, E: guillaume.delefortrie@mow.vlaanderen.be

the additional goods need to be transported by alternative means, particularly by inland waterways. Belgium has a dense inland waterway network that is well integrated into the European waterway system and which still has sufficient capacity. The ports of Antwerp and Ghent are accessible for inland vessels without any restriction. As a result, a substantial fraction of the maritime traffic is transported to and from the hinterland in this way: for example, in 2007 the contribution of inland vessels in the modal split reached 36% for Antwerp and even 61% for Ghent (RSD, 2008). The coastal ports of Zeebrugge and Ostend, on the other hand, are currently only accessible for inland vessels of class IV (1350 ton), which, in combination with the long travelling times due to the passage of bridges and locks, is not sufficient to guarantee an efficient hinterland connection. As a result, only about 1% of the hinterland transport of the port of Zeebrugge is realised by inland ships, see Table 1.

Table 1. Port of Zeebrugge (2010): modal split in 10³ ton (Port Authority Zeebrugge, 2011).

Cargo Type	Transshipment Feeder	Estuary Traffic	Inland Navigation	Rail	Road	Pipeline	Total
Roro	459	42	0	380	11,515	0	12,396
Containers	7,712	871	132	6,812	10,877	0	26,404
General Cargo	5	0	90	501	513	0	1,109
Liquid Bulk	1,124	1,219	0	41	676	4,937	7,997
Dry Bulk	0	0	58	0	1,636	0	1,694
Total	9,300	2,132	280	7,734	25,217	4,937	49,600
% Total traffic	18,8%	4.3%	0.6%	15.6%	50.8%	10.0%	100.00%
% Hinterland Traffic	-	5.3%	0.7%	19.2%	62.6%	12.3%	100.00%

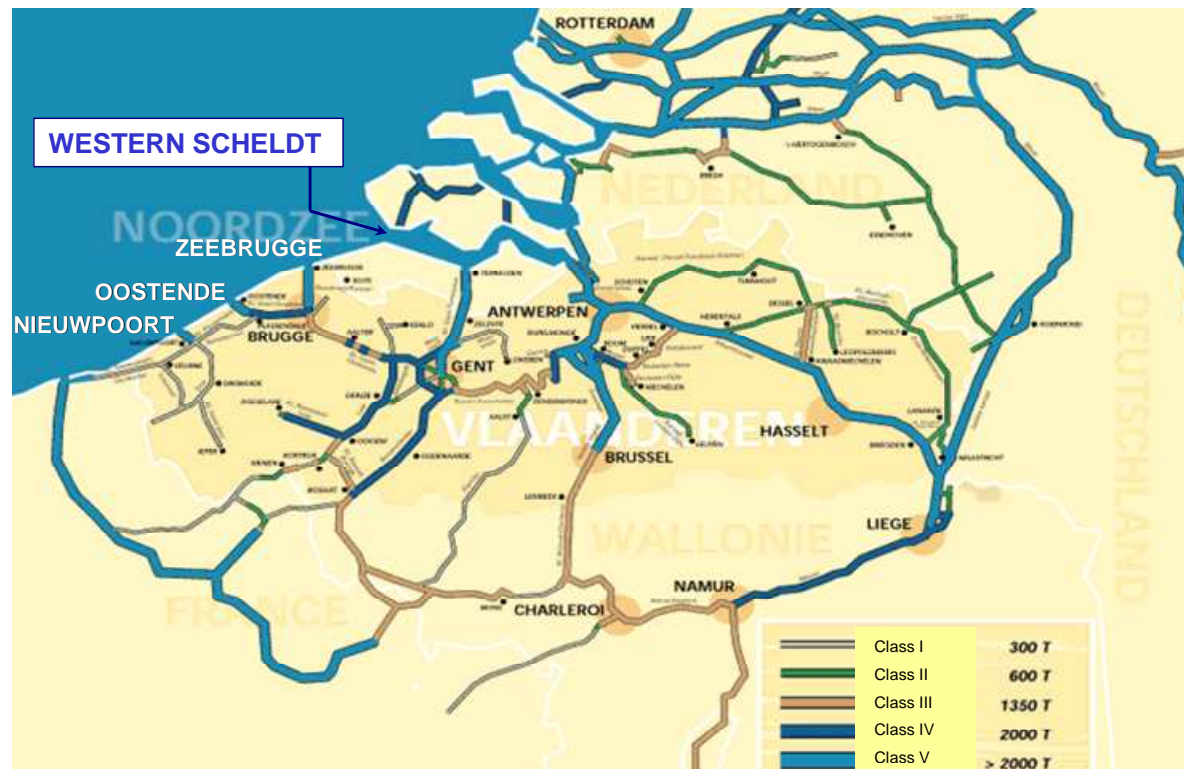

Figure 1. Location of Belgian coastal harbours and inland waterways network. Source: adapted from Promotie Binnenvaart Vlaanderen.

On the other hand, from the outer harbour of Zeebrugge, only a limited trajectory has to be covered to reach the mouth of the Western Scheldt estuary, which gives access to the ports of Antwerp and Ghent and to the European inland navigation network (Figure 1). As a matter of fact, the distance between the breakwaters of Zeebrugge and the line between the Dutch towns of Flushing and Breskens is only 16 nautical miles, while the wave climate in this sea stretch is rather moderate. Although it typically takes only two hours to cover this distance, it is not allowed, even not in favourable weather conditions, to perform this journey by inland vessels. Indeed, the latter are not designed for the additional wave bending moments and do not have a sufficient freeboard. In this respect, it should be mentioned that according to the Directive of the European Parliament and of the Council laying down technical requirements for inland waterway vessels (2006), the Belgian part of this trajectory is geographically not classified as Community inland waterway, while in the Netherlands, the Scheur, the Scheldt and Western Scheldt and its mouth on the sea are classified as Community inland waterways of zone 2. In these zones, inland vessel traffic is allowed, although additional technical requirements can possibly be adopted by the Member State.

The limited access to the coastal harbours for inland ships was, even before the expansion of the port of Zeebrugge in the 1970s, an important issue for bunkering: for bunkering companies having their main activities in Antwerp it was not straightforward to supply fuel to the sea-going vessels calling at Zeebrugge by means of inland vessels. Especially for this type of traffic, a solution was offered by so-called estuary vessels. Classification societies may assign a range of navigation to an inland vessel on stretches of water where waves can develop up to a certain limited wave height, provided that they have a structure with suitable scantlings. For such vessels, a service rule was issued by the Belgian Shipping Inspectorate in 1962 containing the regulations for inland waterway vessels operating between the Western Scheldt and Zeebrugge with qualified crew and in favourable weather conditions, i.e. characterised by a significant wave height (H_s) not greater than 1.2 m (or, in practice, 5 Beaufort wind force).

The additional requirements concerned, among others, life saving appliances, radio equipment, nautical instruments, collision regulations (COLREG), freeboard and strength. The prescribed minimum freeboard depended on length and type of vessel, including minimum values for depth and flare. For strength requirements reference was made to the classification society rules for vessels operating in a maximum of 1.2m significant wave height. Vessels built according to these regulations were mostly smaller tankers with a length of 70 to 80 m, which can easily fulfil the additional strength and safety requirements.

With the dramatic growth of Zeebrugge as a container port in the first decade of the 21st century, as shown in Figure 2, and increasing congestion of the motorways, alternatives for an efficient hinterland connection were more than welcome. Estuary traffic could make a contribution, but the 1.2 m significant wave height restriction appeared to be too strict to guarantee a reliable hinterland connection. This is illustrated in Figure 3, displaying a cumulative distribution of wave observations at location *Bol van Heist*, outside the outer harbour of Zeebrugge. In about 16% of the observations, the significant wave height appears to exceed the 1.2 m value; during the winter months, this value increases up to 29%. For this reason, the Belgian Shipping Inspectorate received several requests from the shipping industry to consider an extension of the limiting conditions for estuary traffic, e.g. up to significant wave heights of 1.6 to 1.9 m. These requests concerned a broad variety of inland vessel types: tankers, container vessels and car carriers.

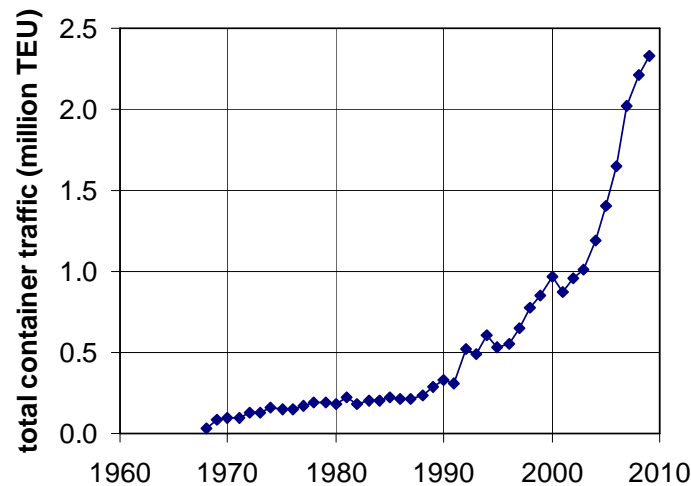

Figure 2. Port of Zeebrugge: evolution of container traffic 1968 – 2009 (Source: Port Authority Zeebrugge, 2009).

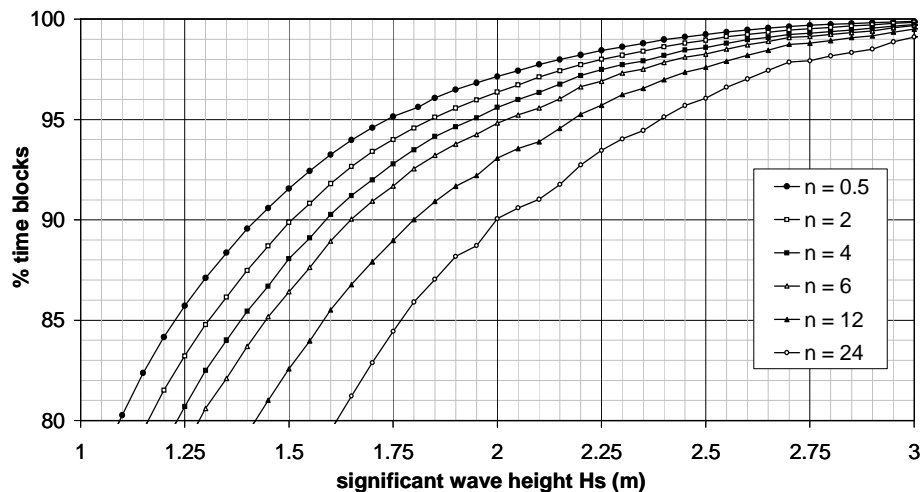

Figure 3. Bol van Heist (Wavec, 1997-2002): Percentage of n hours time blocks during which the significant wave height is not exceeded (Vantorre et al, 2006).

In an initial stage (2004 – 2007), these requests were taken into consideration by the Inspectorate on an individual base, in close consultation with the classification society involved. In March 2007, a *Royal Decree concerning inland vessels also used for non-international sea voyages* (Belgisch Staatsblad / Moniteur Belge, 2007) entered into force, supplying a set of regulations and criteria to be fulfilled by inland navigation ships operating between the Belgian coastal harbours (Zeebrugge, Ostend, Nieuwpoort) and the Belgian inland waterways network via the Western Scheldt estuary.

The present paper intends to describe the general principles of *estuary vessels*, a (non-official) terminology used in practice for *inland vessels also used for non-international sea voyages*, and the outlines of the present regulations. The latter require that for each vessel a risk analysis has to be executed to prove that the probability of occurrence of undesired events caused by waves at sea is acceptably low. The calculations performed in the frame of this risk analysis are described, and a number of typical results are discussed.

2. Principles of estuary navigation

In order to allow ships for inland navigation at sea, two parties are involved: the flag state authority and the classification society. Both have complementary roles in safety at sea. The flag state is committed to the safety of people on board of ships and the protection of the marine environment by means of internationally agreed and national regulations; typical aspects are stability, freeboard, fire safety. The classification society is taking care of the safety of the ship and her cargo through class rules, prescribing minimum requirements for the ship's structure and the major systems on board (Truijens et al, 2006).

Rules and regulations issued by classification societies for inland waterways vessels are framed for ships operating in areas characterised by the absence of wave action. In the Rules of Lloyd's Register (2008), such an area is defined as "Zone 3": "a zone where the maximum significant wave height based on long term significant wave height statistics, excluding the highest five per cent of the observed waves, does not exceed 0.5 m". Zones 1 and 2 are characterised by a maximum significant wave height of 1.6 m and 1.0 m, respectively; for ships intended to operate in these zones, proposed scantlings and arrangements will especially be considered. For instance, concerning longitudinal strength, it is acceptable to neglect wave bending moments and wave shear forces for ships sailing in Zone 3, while for ships designed, modified and/or arranged for navigation in Zones 1 or 2, the additional wave bending moment and shear force have to be taken into account for the calculation of the required hull section modulus.

The Rules for the classification of inland navigation vessels issued by Bureau Veritas (2010) make use of a slightly different, but comparable distinction: navigation notation NI2 is "granted to vessels deemed suitable to navigate on stretches of water where there may be strong currents and a certain roughness of the surface but such as a significant wave could not develop", while the "notation NI1 is granted to a vessel with strengthened structure being considered capable to navigate in semi-maritime stretches of water of lakes when the maximum significant wave height (...) does not exceed 1.20 m". Since about 1991, a notation "NI1 (X m)" is added, for vessels capable to navigate in stretches with a significant wave height up to X meters, X being a value between 1.2m and 2.0m.

Sea states higher than about 1.6 m (i.e. surpassing LR Zone 1) not only imply higher values of the wave bending moments and shear forces; the probability of other critical phenomena increases as well. Sea going vessels are designed to withstand fatigue loads caused by the transient response to impact loadings due to slamming and shipping of water on deck ("green seas"). The structure of inland ships, on the other hand, does not allow these additional loads. In order to guarantee safe operations, either the construction of inland vessels for "estuary" service would have to be modified thoroughly to resist the mentioned transient loads, or both slamming and shipping of water should practically not occur during the ship's lifetime.

It was decided that "estuary" vessels would be conceived as inland vessels with increased longitudinal strength, allowed to operate in seaways up to a specified maximum significant wave height, provided that the draft and the freeboard are sufficient to avoid slamming and green seas, respectively. The range of allowed loading conditions has to be determined by means of a risk analysis which must demonstrate that the probability of occurrence of critical phenomena stays within acceptable limits. Besides slamming and green seas, these phenomena also include deck wetness limitations and shipping of water in the cargo holds in case of open hatch (container) vessels. Additionally, an estimation must be made of the wave loads (bending and torsional moments), rolling angles and accelerations that the vessel will encounter during its lifetime. Finally, the vessel has to meet intact stability criteria similar to those imposed by IMO to sea going general dry cargo vessels.

In the period 2004 – 2007, several inland vessels received a certificate for the stretch between the Western Scheldt and Zeebrugge in seaways up to 1.6 to 1.75 m significant wave height, based on individual studies supported by a risk analysis. In that period, preparations were made for new regulations replacing the old 1962 service rule.

3. Present regulations: Royal Decree of 8 March 2007

3.1. Overview

Instead of adapting the 1962 regulations for estuary vessels, it was decided to develop a completely new set of regulations, taking advantage of the experience gained over several decades with seagoing inland waterway vessels but also introducing the principle of risk analysis. The new regulations entered into force in March 2007 with the publication of a Royal Decree (Belgisch Staatsblad / Moniteur Belge, 2007). The validity of certificates for existing ships under the 1962 service rule will cease on a fixed date in the future.

The scope of the new regulation is restricted to fully certified inland waterway vessels transporting cargo on non-international voyages and going out to sea in a restricted area between the Scheldt estuary and the ports on the Belgian coast under verifiable restrictions regarding swell, freeboard, speed and loading condition. These restrictions are annotated in the Supplementary Community inland navigation certificate of the vessel. This annotated certificate, delivered by the Belgian inspection body for inland navigation, has a validity of five years and is subject to a yearly survey. It is mandatory to register the vessel with an approved organisation; it must be classified, for the hull and the machine installations, in the highest class of its category. The vessel needs full ADN certification (Regulation for the carriage of dangerous substances on the Rhine) and the competence of the crew will have to be supplemented with specific STCW-certification.

Annex I to the regulations gives a list of requirements supplementing those under the existing regulations for inland waterway vessels further ensuring the vessel's 'restricted seaworthiness':

- Chapter 1 requires full compliance with the European marine equipment directive as well as with MARPOL and COLREG regulations.
- Chapter 2 requires compliance with restrictions of a statistical type, on slamming, water intake, roll of vessel, bending moment, torsion and accelerations, which has to be demonstrated through a risk analysis for certain types of ships (see 3.2). The methodology of the analysis is described in the Appendix to Annex I. The restrictions annotated in the Supplementary Community inland navigation certificate of the vessel are based on the results of this risk analysis endorsed by the Belgian maritime inspectorate. For vessels with watertight steel hatch covers or with a watertight deck (tankers) operating in significant wave heights of 1.2 m and less, a risk analysis is not required; instead, they have to fulfil the following requirements:
 - Minimal freeboard $0.5 \text{ m} + (L - 50) * 0.005 \text{ m}$ (L = length between perpendiculars, m);
 - For vessels with a watertight deck (tankers), the freeboard may be reduced by 0.1 m provided that they have a continuous trunk at least 0.7 m high;
 - For ships with watertight steel hatches, hatch covers must be at least 0.9 m high;
 - The sheer must be at least 0.9 m at the bow and 0.5 m at the stern.

- These requirements are identical to those mentioned in the 1962 service rule. If a risk analysis were executed for an inland vessel meeting the requirements mentioned above, the allowable significant wave height would be approximately 1.2 m.
- Chapter 3 formulates supplementary requirements on the different aspects of fire safety measures, stability, freeboard, container stowage and structural strength. The stability requirements, to be fulfilled by ships operating in a significant wave height over 1.2 m, are based on the Code on intact stability for all types of ships covered by IMO instruments, including the Severe wind and rolling criterion, although some of the requirements are somewhat reduced. A heeling experiment is required.
- Chapters 4-10 give requirements on draft scales, manoeuvrability, navigation aids, communication equipment, propulsion, bilge pumps, electrical installations, fire fighting equipment, anchor equipment, personal life saving equipment, bulwarks and railings.

Annex II determines the minimum standards of the assessment procedures for the captain to decide whether or not to start the voyage. On the basis of actual measurements and predictions of weather and wave height from an approved information provider, the procedure will provide the captain with a 'go / no go' answer subject to the annotated restrictions. The procedure needs basic approval by the Belgian Shipping Inspectorate.

3.2. Risk analysis

Criteria

Concerning the behaviour of the vessel in a seaway, the new regulations require a number of probabilistic conditions to be fulfilled. For all probability calculations, it is assumed that the vessel performs 300 round trips per year during a 20 years' lifetime.

- The probability that the most forward point of the ship's keel (point 1 in figures 4a/b) emerges from the water (which may cause slamming) must not be more than once a year.
- The probability that the water reaches the fore deck or the top of watertight bulwarks on the forecastle (points 2, 3, 4 in figures 4a/b), causing green water, must not exceed once in a lifetime. In determining the relative vertical motion at the bow (point 2), an allowance δz must be taken into account for the height of the bow wave and the dynamic piling-up as a result of diffraction and radiation. If no reliable empirical data from model or full-scale tests are available, the regulations provide a formula to calculate this allowance δz :

$$\delta z = 0.2z_1 + 0.6 \frac{V^2}{2g} \quad (2)$$

- z_1 being the level reached once in a lifetime of the vessel (m), V the speed (m/s) of the ship reached with 80% of the propulsive power and g the acceleration of gravity (9.81 m/s^2). The first term ($0.2 z_1$) accounts for the dynamic piling-up, the second term for the height of the bow wave. A typical value for the latter is 0.81 m for a speed of 10 knots (18.5 km/h, 5.14 m/s). Watertight bulwarks must extend at least 7% of the length between perpendiculars aft of the fore perpendicular.
- The probability that the water level exceeds a reference level at the sides must not be greater than once in a lifetime. This reference level is defined as follows:
 - in case of vessels with watertight steel hatch covers: at the top of the hatch coamings;

- in case of vessels with open hatches, the lowest of the following two levels (points 5 through 10 in Figure 4b):
 - at a safety distance under the top of the hatch covers, being 20% of the vertical distance between the waterline and the top of the hatch covers (Figure 4c: level 1),
 - 0.90 m above the deck at side (Figure 4c: level 2);
- in case of vessels with a continuous watertight deck (Figure 4d): 0.90 m above the deck at side at the midship section (Figure 4a/b: points 5-6); 1.35 m above the deck at other sections (points 7, 8, 9, 10). If lower decks are located aft of the main deck (Figure 4a: points 9b-10b), these decks need to fulfil this requirement as well.
- The probability that the water reaches the aft deck or the top of watertight bulwarks on the aft deck must not exceed once in a lifetime (Figures 4a/b: points 11 to 14). Watertight bulwarks must extend at least 7% of the ship's length fore of the aft perpendicular.
- The probability that the roll angle exceeds 67% of either the angle of flooding (i.e. the angle at which openings that cannot be sealed are immersed) or the angle corresponding with the maximum of the stability curve must not be greater than once in a lifetime; the roll angle must never exceed 15 degrees.
- With respect to strength conditions to be fulfilled, the values occurring once in a lifetime of following phenomena due to wave action must be calculated as well: the vertical longitudinal bending moment, the torsional moment (except for ships with a continuous watertight deck), the lateral accelerations of the telescopic wheelhouse in its highest position (point 15 in figures 4a/b), if present, and of cargo carried on deck (points 16 through 21 in Figure 4b).

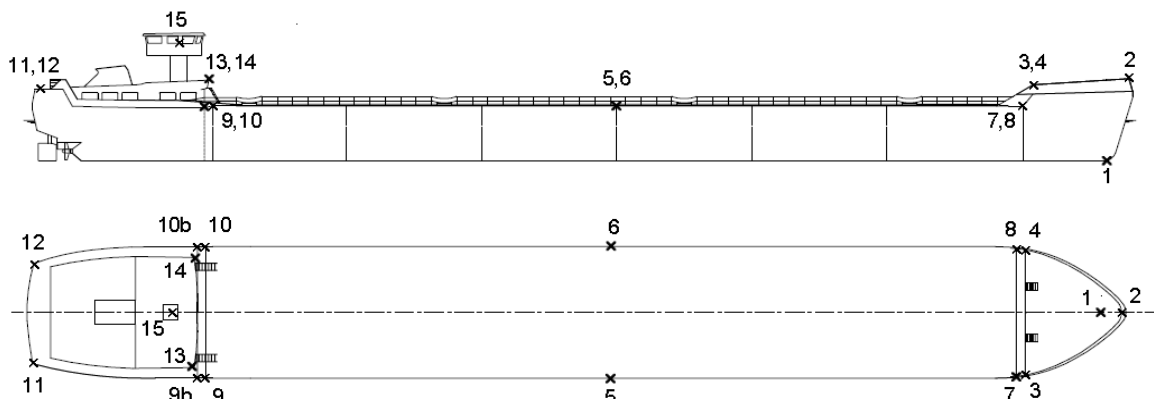

Figure 4a. Critical points to be considered in a risk analysis: tanker.

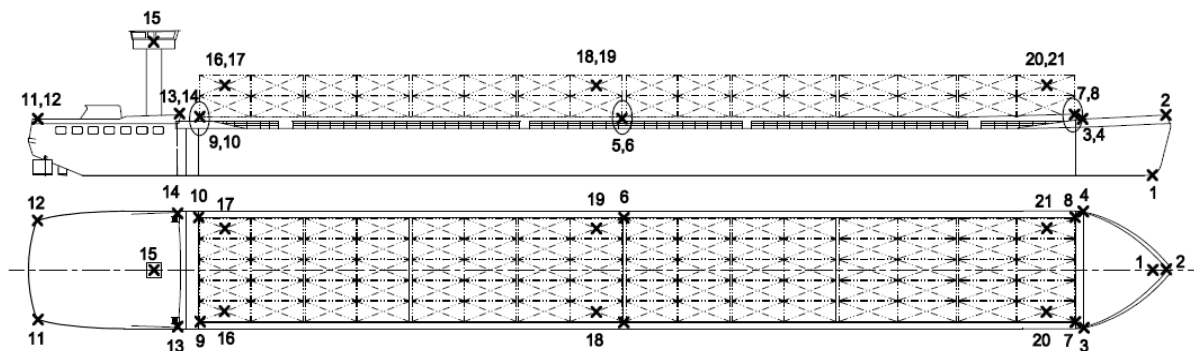

Figure 4b. Critical points to be considered in a risk analysis: container carrier.

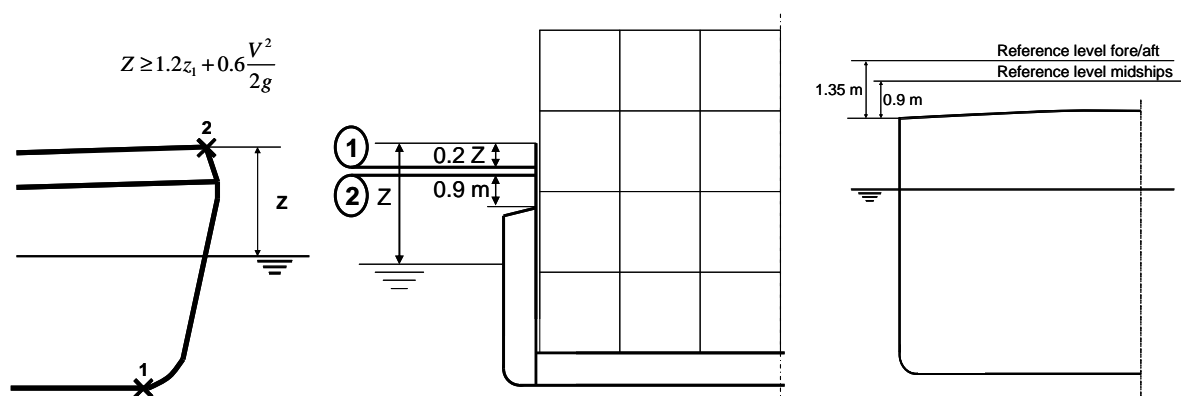

Figure 4c (left). Required height of fore deck or top of bulwark on the forecastle ($z_1 =$ level reached once in a lifetime).

Figure 4d (middle). Reference levels at the side to be considered in case of vessels with open hatches, referring to points 5 to 10 in Figure 4b).

Figure 4e (right). Reference levels at the side to be considered in case of vessels with a continuous watertight deck (referring to points 5 to 10 in Figure 4a).

Calculation method

The ship's response must be calculated in wave conditions that are considered to be realistic and representative for the navigation area. The study must be based on the response on all directional wave spectra derived from observations during one year. For the determination of the response, it is allowed to use response amplitude operators (RAO) for the relative vertical motion of the selected points on the hull, the bending and torsional moments, the roll angle and the accelerations based on a linear theory in the frequency domain. The calculations must be executed for realistic loading conditions and weight distributions.

The sea trajectory is approximated by a number of subsequent linear tracks for which the ship's heading and speed are considered to be constant; a distinction has to be made between the outbound and inbound passages. For each sub-trajectory, the response spectra are calculated, which allows calculation of the following required statistical information:

- the significant response value, from which the exceedance probability per oscillation of a considered level can be calculated;
- the average period of the response;
- the exceedance probability of a considered level during the entire out- and inbound trip.

For each of the events linked to the criteria, the maximum significant wave height needs to be determined for which the accepted exceedance probability is reached. The following methodology is applied:

- the response of the ship is calculated for each directional wave spectrum observed during the year considered; for each event the number of expected exceedances is calculated;
- all individual directional wave spectra are grouped in wave height classes with an interval not exceeding 0.05 m . For each of the classes, the minimum, maximum and average values are plotted as a function of H_s ; these values are called the conditional minimum, maximum and average number of exceedances per journey, respectively;
- as a function of H_s , the cumulative average number of exceedances per journey is calculated, which is defined as the average number of times the critical value is expected to be exceeded

during any return trip, if a particular value of the significant wave height is considered as a maximum allowable value and is therefore never exceeded. Special attention is paid to the values of the maximum allowable significant wave height for which this cumulative average equals 1/300 (once a year) and 1/6000 (once in a lifetime).

3.3. Present fleet

The present fleet (November 2011) of *inland vessels also used for non-international sea voyages* consists of ten tankers (5 for $H_{s,max} = 1.2\text{m}$; 3 for 1.6m; 1 for 1.9m; 1 for 2.0m), three car carriers (1.75m) and four container carriers (3 for 1.7m; 1 for 1.9m); one more tanker is under construction. Classification societies involved are Bureau Veritas and Lloyd's Register. As can be derived from Figure 3, a significant wave height limitation to 1.75 m and 1.90 m reduces the downtime to about 5% and 3.5%, respectively. A further reduction to 1%, for example, would imply that the ships should be adapted to a significant wave height of 2.4 m, which is considered to be unrealistic.

4. Practical approach

This paragraph intends to describe the way the risk analysis for the present fleet of estuary vessels has been performed by the Maritime Technology Division of Ghent University.

4.1. Trajectories

Most of the estuary shipping traffic is limited to the trajectory between the mouth of the Western Scheldt and Zeebrugge, which can be approximated by a straight line with heading 250 deg outbound and 70 deg inbound; a distance of 16 nautical miles (one way) is covered. If, however, the ship owner plans to cover the complete coastal zone, an additional trajectory Zeebrugge - Nieuwpoort, with a length of 22 nm, has to be covered, which can be approximated by a straight line with heading $\mu_0 = 235 \text{ deg} / 55 \text{ deg}$ and distance 22 nm.

4.2. Wave data

A hydrometeo-system has been set up to deliver real-time hydrometeo information and forecasts in order to optimise safe and fluent vessel traffic to and from the Belgian harbours. A monitoring network in the Belgian part on the North Sea and along the coast, consisting of measuring piles and buoys, measures wind, waves, water levels, currents and other parameters. These data are transmitted to the coast, processed and distributed in real-time to the key-users. The Oceanographic Meteorological Station (OMS), a hydrometeo forecast centre located in Ostend, produces four forecasts a day, seven days a week. These weather bulletins are distributed to the key-users: nautical authorities (pilots, shipping assistance and VTS), port authorities and other partners. The monitoring network and the forecast centre are managed and operated by the Agency for Maritime and Coastal Services (MDK) of the Flemish Government.

For the risk analysis, the vessel's response to all directional spectra measured at location *Bol van Heist* during one year is calculated for the trajectory Western Scheldt - Zeebrugge. For the stretch Zeebrugge - Nieuwpoort, the data of a directional wave buoy near Oostende are used (Figure 5). For both locations, directional spectra based on wave records taken with 30 minutes interval are available for several years. For a one-year period, about 15,000 spectra are available, taking account of periods of failure. The directional spectra consist of values for the spectral density, the average wave direction and the directional spreading for 100 frequencies; for further processing, these data are converted into a 100*36 table containing spectral density values $S_{\zeta}(\omega, \mu)$ for each combination of frequency ω and direction μ .

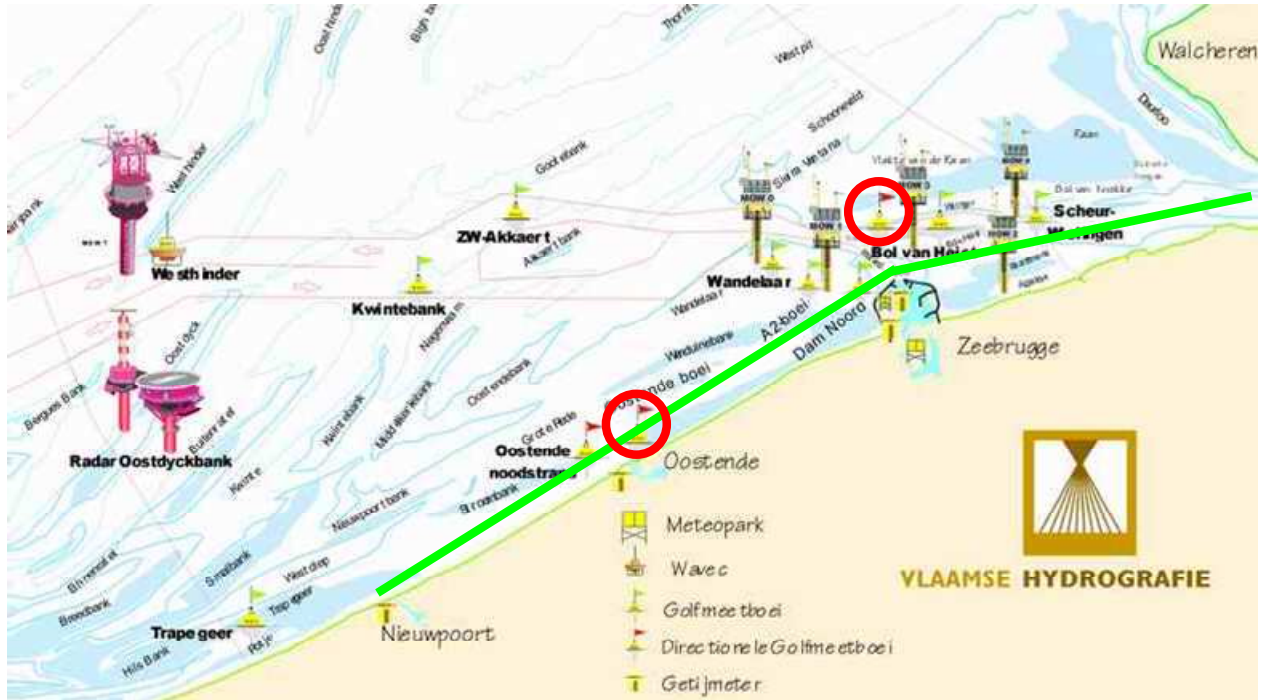

Figure 5. Measuring Network Flemish Banks (Meetnet Vlaamse Banken). Trajectories (green lines) for estuary traffic Western Scheldt – Zeebrugge – Nieuwpoort and locations of directional wave buoys (red circles) Bol van Heist and Oostende. Source: adapted from Vlaamse Hydrografie.

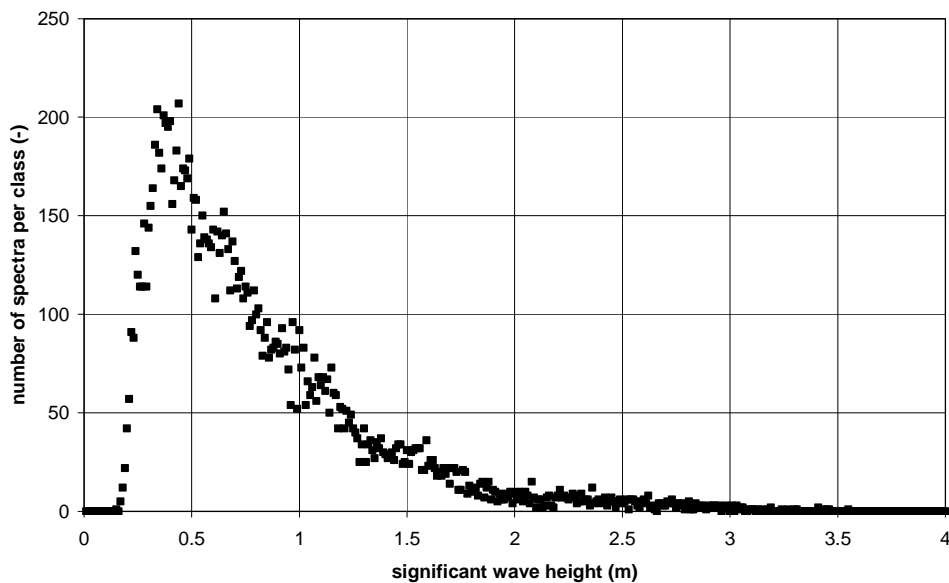

Figure 6. Spectra Bol van Heist 1998: distribution of wave height classes (0.01 m interval).

The spectra are grouped in discrete H_s -classes $]H_{sj} - \delta H_s ; H_{sj}]$, with $H_{sj} = j \delta H_s$. Taking account of the large number of data, wave height classes are defined with $\delta H_s = 0.01$ m intervals. Figure 6 shows the number of spectra in each interval for the measurements at Bol van Heist in 1998. The number of spectra in wave height class j is denoted n_j^{cond} .

4.3. Response calculation

The RAOs required for calculating the response spectra and the exceedance probability of the critical levels have been calculated with *Seaway*, a software package developed by Journée Shipmotions bv, presently incorporated into Octopus (Amarcon bv). It is a frequency-domain ship motions PC program based on the linear strip theory to calculate the wave-induced loads, motions, added resistance and internal loads for six degrees of freedom of displacement ships and yachts, barges, semi-submersibles or catamarans, sailing in regular and irregular waves. The program is suitable for deep to very shallow water. Viscous roll damping, bilge keels, anti-roll tanks and linear springs can be added. Work of acknowledged hydromechanical scientists (like Ursell, Tasai, Frank, Keil, Newman, Faltinsen, Ikeda, etc.) has been used, when developing this modified strip theory based code.

The *Seaway* output files are converted into a number of 100 (frequencies) * 36 (directions) tables containing the response functions; the amplitude of a response R to a regular wave with a unity amplitude, frequency ω and relative direction μ_R is denoted $Y_{R\zeta}(\omega, \mu_R)$.

The RAOs depend on the ship's speed and the local water depth. As prescribed, the calculations are carried out with the speed reached with 80% of the installed power, typically 10–11 knots. An estimation for this speed is made by empirical methods. The calculations are performed for a water depth $h = 10$ m, which can be considered as an average temporal and spatial value for the stretch between Zeebrugge and the Western Scheldt.

4.4. Calculation of exceedance frequencies of ship responses for a given wave condition

Based on the directional wave spectrum and the RAO, a directional response spectrum for a particular response of a ship navigating with a heading μ_0 can be calculated:

$$S_R(\omega, \mu) = S_\zeta(\omega, \mu) \cdot Y_{R\zeta}^2(\omega, \mu - \mu_0) \quad (2)$$

Integration of this response spectrum yields:

$$m_{0,R} = \int_0^\infty \int_0^{2\pi} S_R(\omega, \mu) d\mu d\omega \quad (3)$$

Similar to the significant wave height H_S , a significant (peak to trough) value $H_{R,S}$ for the response R can be defined as follows:

$$H_{R,S} = 4.0 \sqrt{m_{0,R}} \quad (4)$$

Assuming that the peak to trough values H_R of the response follow a Rayleigh distribution:

$$p(H_R) = 4 \frac{X_R}{H_{R,S}^2} e^{-2 \left(\frac{H_R}{H_{R,S}} \right)^2} \quad (5)$$

The exceedance probability of a particular value H_{R0} during each individual oscillation is:

$$P[H_R > H_{R0}] = \int_{H_{R0}}^\infty p(H_R) dH_R = e^{-2 \left(\frac{H_{R0}}{H_{R,S}} \right)^2} \quad (6)$$

The average apparent period of one oscillation, i.e. the average time between two upwards zero-crossings for the considered response, can be estimated as follows:

$$T_{z,R} = 2\pi \sqrt{\frac{m_{0,R}}{m_{2,R}}} = 2\pi \sqrt{\frac{\int_0^{\infty} \int_0^{2\pi} S_R(\omega, \mu) d\mu d\omega}{\int_0^{\infty} \int_0^{2\pi} \omega_e^2 (\mu - \mu_0) S_R(\omega, \mu) d\mu d\omega}} \quad (7)$$

ω_e being the encounter frequency:

$$\omega_e = \omega - kV \cos(\mu - \mu_0) \quad (8)$$

with V the ship's speed, and k the wave number:

$$k \tanh kh = \frac{\omega^2}{g} \quad (9)$$

The average number of oscillations N_i occurring in a sub-trajectory with length L_i equals:

$$N_i = \frac{L_i}{VT_{z,R}} \quad (10)$$

As a result, the average number of exceedances during the passage of the sub-trajectory can be estimated as $N_i P[H_R > H_{R0}]$. Summation over all sub-trajectories results into the expected total **number of exceedances** per round trip NER in the given sea condition.

4.5. Assessment of the criteria

The calculations described in 4.4 are performed for all spectra of the considered year. For each wave height class j (see 4.2), the following values are calculated:

$$NER_{\max}^{cond}(Hs_j) = \max_{i=1}^{n_j} NER_{ij} \quad (11)$$

$$NER_{\min}^{cond}(Hs_j) = \min_{i=1}^{n_j} NER_{ij} \quad (12)$$

$$NER_{avg}^{cond}(Hs_j) = \frac{1}{n_j^{cond}} \sum_{i=1}^{n_j} NER_{ij} \quad (13)$$

NER_{ij} being the expected total number of exceedances per round trip in wave spectrum i of wave height class j ; NER^{cond} stands for **conditional number of exceedances**.

The **cumulative average number of exceedances** can be calculated as follows:

$$NER_{avg}^{cum}(Hs_j) = \frac{\sum_{k=1}^j n_k^{cond} NER_{avg}^{cond}(Hs_k)}{\sum_{k=1}^j n_k^{cond}} = \frac{\sum_{k=1}^j n_k^{cond} NER_{avg}^{cond}(Hs_k)}{n_j^{cum}} \quad (14)$$

It is the average number of times the critical value is expected to be exceeded during any crossing, if a particular H_s value is selected as a maximum allowable value. Figure 7 shows an example of the conditional and cumulative number of exceedances as a function of significant

wave height. Two values for the cumulative average are of particular importance: 1/300 (corresponding with an occurrence of once in a year) and 1/6000 (once in a lifetime).

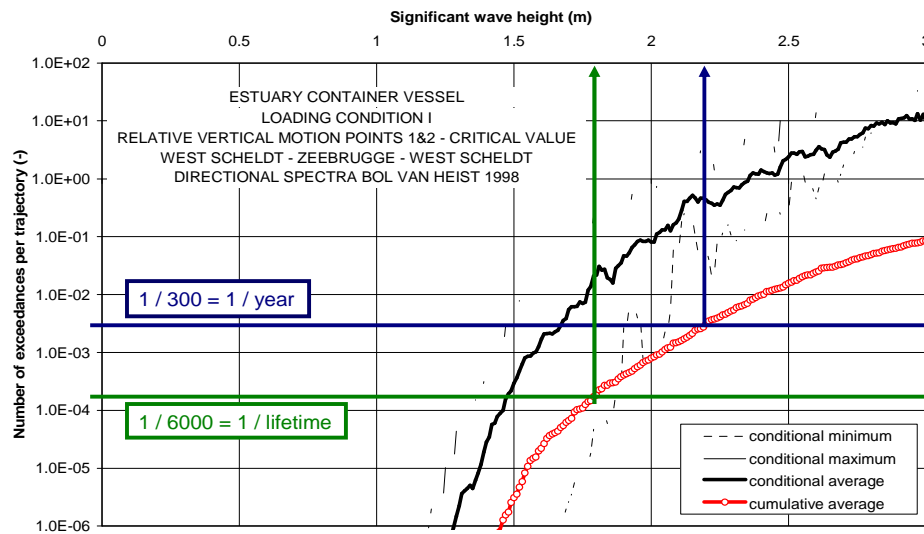

Figure 7. Example of a plot showing the relation between the actual significant wave height and the (conditional) minimum, maximum and average number of times a given critical level is expected to be exceeded during a crossing, as well as the relation between the maximum allowable significant wave height and the (cumulative) average number of times the critical value is expected to be exceeded during any crossing (Vantorre et al, 2006).

4.6. Special considerations

In order to optimise the ship's operations, the conditions in which a vessel is allowed to navigate may depend on the weather conditions or the trajectory. Two examples:

Two values of the maximum draft can be considered, for two different maximum values for the significant wave height. For example, in seas up to a significant wave height of $H_{s,j1} = 1.60$ m, a draft of $T_1 = 4.50$ m is allowed, while for seas between $H_{s,j1} = 1.60$ m and $H_{s,j2} = 1.90$ m, navigation is still allowed if the draft is not greater than $T_2 = 4.05$ m. In that case, the cumulative probability can be calculated as follows:

$$\begin{aligned}
 NER_{avg}^{cum}(H_{s,j_2}) &= \frac{\sum_{i=1}^{j_1} \sum_{k=1}^{n_i} NER_{ik}(T_1) + \sum_{i=j_1+1}^{j_2} \sum_{k=1}^{n_i} NER_{ik}(T_2)}{\sum_{i=1}^{j_2} n_i} \\
 &= \frac{\sum_{i=1}^{j_1} n_i^{cond} NER_{avg}^{cond}(H_{s_i}; T_1) + \sum_{i=j_1+1}^{j_2} n_i^{cond} NER_{avg}^{cond}(H_{s_i}; T_2)}{n_{j_2}^{cum}} \\
 &= \frac{n_{j_1}^{cum} NER_{avg}^{cum}(H_{s_{j_1}}; T_1) + n_{j_2}^{cum} NER_{avg}^{cum}(H_{s_{j_2}}; T_2) - n_{j_1}^{cum} NER_{avg}^{cum}(H_{s_{j_1}}; T_2)}{n_{j_2}^{cum}} \\
 &= NER_{avg}^{cum}(H_{s_{j_2}}; T_2) + \frac{n_{j_1}^{cum}}{n_{j_2}^{cum}} (NER_{avg}^{cum}(H_{s_{j_1}}; T_1) - NER_{avg}^{cum}(H_{s_{j_1}}; T_2))
 \end{aligned}$$

(15)

A ship can be allowed to navigate in the complete coastal zone between the Western Scheldt and Nieuwpoort, with different values for the maximum allowable significant wave height for the stretches Western Scheldt – Zeebrugge and Zeebrugge – Nieuwpoort. As mostly the first stretch is the most important one, the limiting H_s for the trajectory Western Scheldt – Zeebrugge has the greatest value.

5. Important parameters

The examples given in this chapter are based on risk analyses carried out for existing ships. So as not to reveal the identity of the ships, only a limited amount of data will be given.

For most existing estuary vessels, the most critical criterion appears to concern overtaking of water in the most forward points of the main deck. However, this is due to the fact that the bow height of most ships is rather over-dimensioned, that the deck and the coamings are preferably horizontal, and that the poop deck is designed sufficiently high while the accommodation under this deck is equipped with windows with proven seaworthiness. Other requirements may become critical if bow, decks and coamings are optimised with respect to the criteria. For different types of inland container vessels, minimum levels are shown as a function of maximum allowable significant wave height by Vantorre et al (2006).

5.1. Loading condition

The most important parameters determining the loading condition are the drafts fore and aft. An inland vessel that is allowed to perform non-international sea travels is entitled to do so between a minimum and maximum value for the draft as mentioned on the certificate. The exceedance probability of critical levels due to motions in waves directly depends on the draft fore and aft, due to their direct relation to the limiting values. On the other hand, the response of ships in waves, and more specifically the roll motion, is highly dependent on the vertical position of the centre of gravity, which determines the metacentric height GM .

This effect is illustrated in Figures 8a/b, which show the maximum allowable significant wave height for which a specific estuary container carrier still fulfils the criterion concerning shipping of water at the side as a function of draft and GM . The allowable significant wave height clearly decreases with increasing metacentric height. The validity of the curve in Figure 8a for low GM values should be questioned. Indeed, the calculation method only accounts for the response of the vessel to waves, while (unsteady) wind action will cause additional roll motions. Wind effects will particularly be of importance for container carriers and ro-ro vessels, but only to a lesser degree for tankers. The safety of vessels subject to a combined action of beam waves and beam wind is studied by Hofman and Bačkalov (2005) and Bačkalov (2010) making use of a nonlinear model; they show that the probability of reaching critical roll angle values initially decreases with decreasing GM , but increases dramatically for (very) low GM values. For realistic GM values, however, which for the vessel considered in Figures 8a/b are typically 1.75 – 3.0 m, the plotted tendency is still valid. As the risk analysis has to cover the complete range of realistic loading conditions, the calculations have to be carried out for at least two GM values. Therefore, an accurate and reliable estimation of the GM range in the design stage is of great importance. This is especially true for container and ro-ro vessels, for which a large number of loading conditions is possible for a given draft. For tankers, on the contrary, the GM variation is much smaller.

The GM value is of particular importance due to its direct effect on the ship's natural roll period, as illustrated in Figure 9 for a tanker. With increasing GM , this natural period decreases and coincides more frequently with the range in the wave spectrum with high energy content (typically 5 – 6 s in the considered coastal zone). Moreover, the height of the peak in the response

amplitude operator increases with the GM value, at least within the considered range, due to the increasing steepness of the waves at resonance frequency.

The metacentric height is a very important parameter for the safety of any ship, and should therefore be known at any time. However, the natural frequency and, therefore, the roll response not only depend on draft and GM , but also on the radius of inertia along the longitudinal axis (k_{xx}). This is illustrated in Figure 9b, for the same tanker. The difference between both response functions has only a minor effect on the allowable H_s , of the order of magnitude of 0.01 - 0.02m; the smallest k_{xx} value leads to a lower limiting wave height.

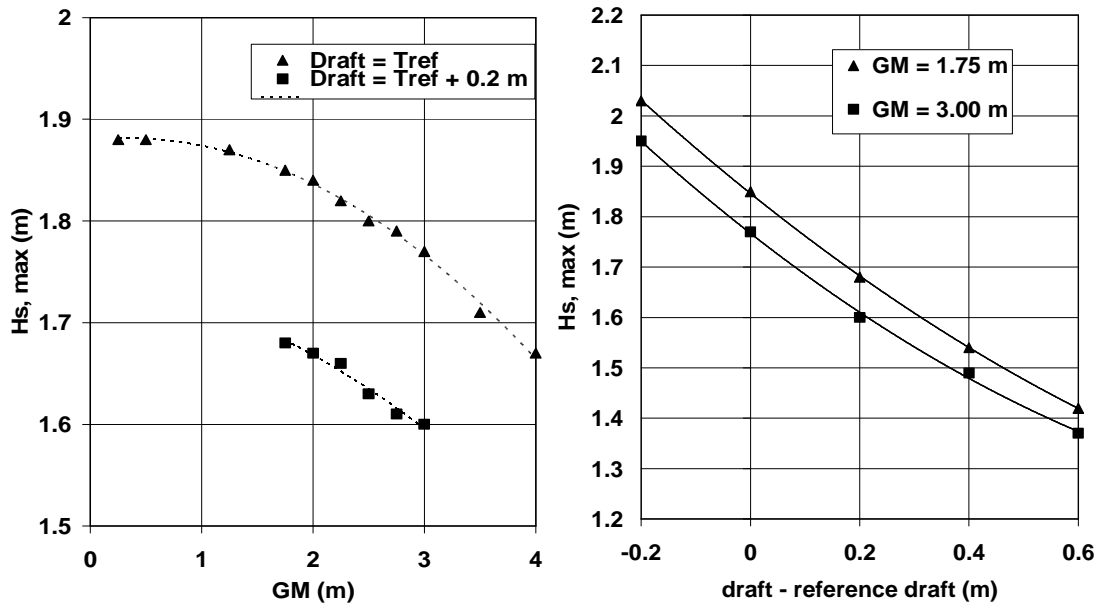

Figure 8. Estuary container vessel: maximum allowable significant wave height as a function of draft and metacentric height (GM).

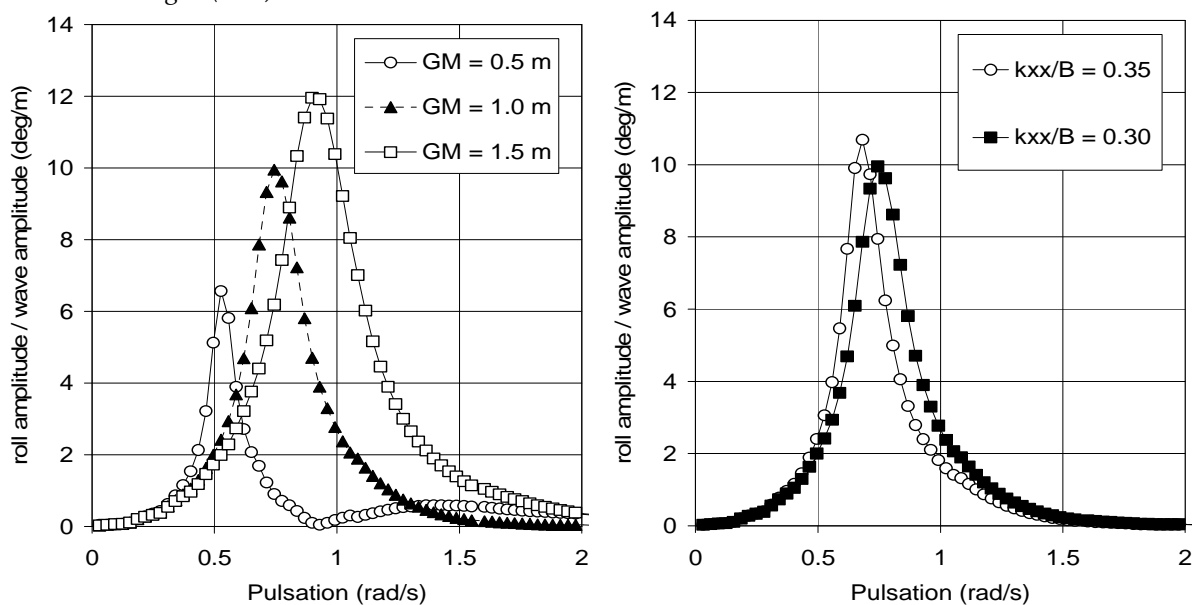

Figure 9. Estuary tanker: effect of loading condition parameters on roll response amplitude operator. Figure 9a (left): effect of metacentric height (GM). Figure 9b (right): effect of radius of inertia along longitudinal axis (k_{xx}).

5.2. Bilge keels

While the GM and k_{xx} values have a direct influence on the natural roll period of a vessel, the magnitude of the peak of the RAO is determined by the damping coefficient. As the hydrodynamic damping, caused by wave radiation, is rather low, the main contribution to roll damping consists of viscous damping. The latter can be increased significantly by adding bilge keels, which is not customary in inland shipbuilding, as contact with structures such as lock walls and quays may lead to severe damage if bilge keels are mounted. As for beam seas bilge keels may reduce the resonance peaks for roll by 25 to 75%, a substantial reduction of roll motions can be realised in this way. The advantage depends very much on the vessel characteristics; as an example, for one type of container carrier the effect in terms of allowable H_s can be estimated as 0.10 m. Such an advantage can alternatively be realised by an increase in freeboard (or a draft reduction) of about 0.13 m in this particular case.

5.3. Trajectory

For several reasons, the trajectory for which the risk analysis is carried out has an important effect on the allowable significant wave height.

The orientation of the trajectory affects the relationship between the wave period and the encounter period experienced by the vessel for each harmonic wave component and, hence, the ship's response. For the same reason, the travel direction is also of importance, so that for a round trip the transit in both directions has to be calculated separately.

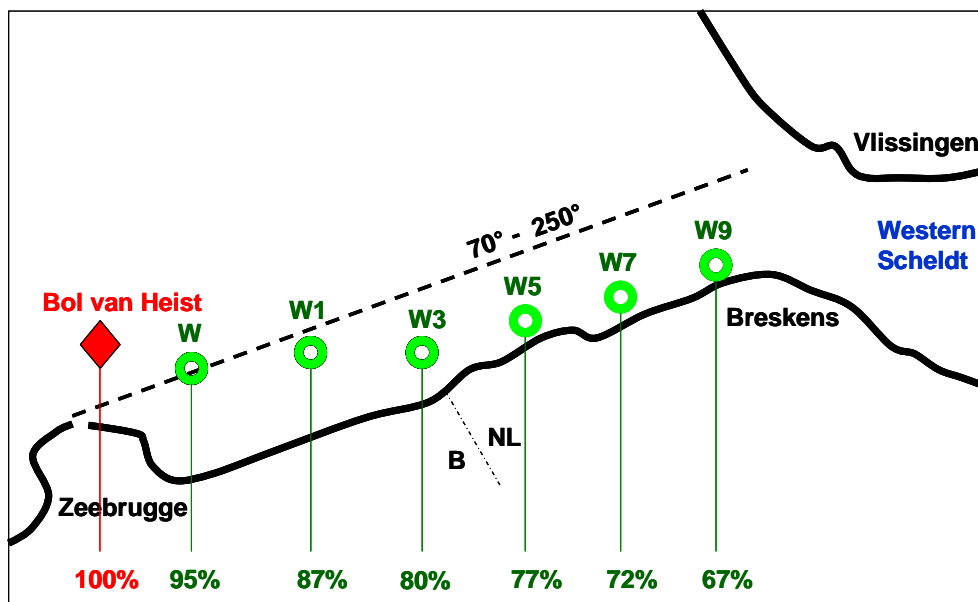

Figure 10. Wave climate variations between Zeebrugge and the Western Scheldt (based on De Beck, 2007).

Even if a rather restricted coastal area is considered, the wave climate may be spatially variable. For this reason, separate datasets are used for the stretches Western Scheldt - Zeebrugge and Zeebrugge - Nieuwpoort. For the traffic between the Western Scheldt and Zeebrugge, the selection of *Bol van Heist* as a reference location implies an approach on the safe side: indeed, an attenuation of the wave conditions can be observed between this location and the mouth of the river Scheldt. The average ratio of the significant wave height at the navigation buoys (W, W1, W3, W5, W7 and W9) on the southern bank of the *Wielingen* channel compared to *Bol van Heist*, based on calculations by Verelst (2006), is shown in Figure 10. The effect of this attenuation on the

results of the risk analysis for estuary container carriers has been studied by De Beck (2007); it was concluded that the relative water levels expected to be reached once in a lifetime are reduced by 6 to 8%, resulting into an extra margin of 0.20 – 0.25 m fore and aft and 0.15 m amidships. Accelerations are reduced by 6 to 7%, bending moments by 6 to 9%.

The length of the trajectory is of importance, as the number of wave cycles encountered by the ship during a voyage depends on the travelling time; consequently, the exceedance probability of critical levels is affected as well. Most estuary vessels have a certificate for the stretch between the Western Scheldt to Zeebrugge, but if a certificate is issued for the whole Belgian coastal area, up to Nieuwpoort, the length of the trajectory is more than doubled. While the regulations stipulate that all probability calculations are based on 6000 round trips during the ship's lifetime, this has a severe consequence on the allowable significant wave height. For this reason, mostly two different maxima for the allowable wave height are used for the stretches Western Scheldt – Zeebrugge and Zeebrugge – Nieuwpoort. Typically, the allowable H_s is maximised for the first stretch, while a lower value (1.20 m or slightly more) is adopted for the zone west of Zeebrugge.

6. Further research

6.1. Research topics

Since 2004, estuary tankers and car carriers are operating in the coastal stretch between Zeebrugge and the river Scheldt in seaways with significant wave height up to 1.80 m; in 2007, container carriers joined the estuary fleet. In this way, the last few years experience has been built up and practical information is available on the operation and exploitation of estuary vessels beyond the 1962 Service Rule. This offers an opportunity to examine some of assumptions on which the new Belgian Royal Decree of 2007 are based. Although the latter is considered to be one of the first safety regulations based on probabilistic rather than purely deterministic principles, a number of effects is still accounted for in a rather pragmatic way.

Flexible admittance policy

For most of the estuary vessels designed and operated according to the 2007 Royal Decree the draft allowed at sea is significantly less than the maximum allowable draft in inland waters, which implies that they are not loaded to full capacity. A relationship can be defined between the maximum allowable significant wave height and the maximum draft at sea, see Figure 8b. With decreasing wave height limit, the downtime increases, but the amount of cargo increases, so that an optimisation from the viewpoint of the ship owner can be carried out. From the point of view of a terminal operator, on the other hand, there is a maximum limit for the downtime in order to guarantee a reliable hinterland connection. As a compromise between both parties, a stepped approach can be considered, so that navigation up to relatively severe sea states is possible with reduced draft, while in moderate waves the ship can be loaded to a deeper draft (see paragraph 4.6). The Belgian federal authorities are willing to accept such a two-stepped certificate, if supported by a risk analysis.

Such an approach could principally be extended to a multiple step or even continuous relationship between wave height and draft, so that the loading condition could be optimally adapted to the actual wave conditions. One of the practical objections against a more complicated admittance policy, however, concerns the wave height forecasts, from which a much higher degree of reliability and accuracy is expected in such an approach, as ships will be operating more frequently in conditions close to their limitations. Especially for vessels loading at an inland terminal, the draft is based on wave forecasts several (6 – 10) hours ahead. In case the forecast

underestimates the significant wave height, the ship will possibly have to wait near the Western Scheldt mouth to start the sea voyage, leading to additional downtime. Therefore, the quality of wave forecasts is clearly of great importance.

Wind induced loads

The risk analysis does not take wind loads into account; instead, deterministic margins are introduced. For example, vessels must meet requirements similar to the *Severe wind and rolling criterion*; the maximum roll angle experienced once in a lifetime must not exceed 67% of the flooding angle; for vessels with open hatches a 0.90m margin is prescribed. A case study by Bačkalov (2010) confirms that the margin for roll is sufficient to compensate for unsteady wind; nevertheless, the overall effect of wind on the probability of shipping of water should be assessed more thoroughly to obtain a deeper understanding of the real limits.

Wave climate

Both risk analyses and operations are based on wave measurements in specific locations, while the wave climate may be variable along the trajectory. This is illustrated in paragraph 5.3, where the effect of wave attenuation in the Wielingen channel is discussed. In this case, the effect is beneficial, but in other areas, e.g. the zone near the breakwaters, the local wave climate could be disadvantageous. Especially in these zones, but also in shallow areas bordering deep water, it can be questioned whether non-linear phenomena still can be neglected.

Other complications may occur when several trajectories are possible. For instance, between Zeebrugge and Oostende, depending on the draft and the tide, navigation is possible inside or outside the Wenduine Bank, which is parallel to the coastline; not only the wave climate may be significantly different, but also the ship's heading and the distance to be covered will affect the relevant exceedance probabilities.

It can also be noticed that the present regulations do account for the effect of other hydro-meteo parameters and their interaction with the wave climate. This is particularly the case for the important tidal currents parallel to the coastline, which not only influences the ship's speed but also may affect the wave characteristics and even cause non-linearities.

Ship response

A risk analysis is always based on a series of numerically calculated response functions. Although potential theory is sufficiently reliable for determining response amplitude operators, some aspects need further consideration. This is particularly the case for the roll motion, which is dominated by phenomena that are highly nonlinear. The results are therefore rather sensitive to the way of linearization of roll damping. In general, a validation of the calculation methods used for the risk analysis is recommendable.

The present regulations imply some margins to account for uncertainties and effects that are not taken into consideration. Besides wind, see paragraph 6.1.2, these margins also are intended to compensate for the effect of diffraction and radiation waves. Similarly, the bow wave elevation could be estimated in a more accurate way than using expression (2).

6.2. Research methods

Presently, a research project is being carried out at Flanders Hydraulics Research (Flemish Government, Antwerp) with the scientific support of Ghent University, concerning the hydrodynamic properties of a specific type of estuary container vessel. A model test program

consisting of captive manoeuvring tests and sea-keeping tests will be carried out in the first half of 2011 in the towing tank for manoeuvres in shallow water. Additionally, the sea-keeping tests will allow the determination of the response of the vessel to regular and irregular waves; the results can be used to validate the RAOs on which the risk analysis is based and, moreover, allows to pay special attention to the relative motion between the ship and the free water surface.

The main purpose of this test program is the development of a mathematical manoeuvring model for a dedicated full mission bridge simulator for inland vessels, LENA (LEarn to NAVigate), that has been developed by Flanders Hydraulic Research for a training centre at Syntra (Sint-Niklaas, Belgium). An inland vessel simulator for research purposes, LARA, was taken into service in December 2010 at Flanders Hydraulics Research. Although until present only the manoeuvring behaviour of inland vessels is simulated, so that the mathematical models are limited to the horizontal degrees of freedom, an extension to six degrees of freedom is planned. Such a time-domain approach can also incorporate nonlinear effects, which offers opportunities to acquire a better understanding of their importance.

Another way of collecting validation data consists of full-scale measurements. Recently Flanders Hydraulics Research has invested in an on-board monitoring system for investigating the behaviour of sea-going and inland vessels, including estuary vessels. The first monitoring campaigns on board of estuary vessels have already taken place.

7. Concluding remark

Estuary traffic by inland vessels can be considered as an alternative way of connecting coastal ports to the hinterland. However, the construction cost of an estuary vessel is higher compared to a vessel strictly operating in inland waterways only, so that this investment has to be used in an optimal way. On the other hand, the safety of the vessel has to be guaranteed in all operating conditions. In order to acquire an acceptable balance between economic efficiency and safety, it is important to gain more insight into the behaviour of estuary vessels in the specific conditions – including the wave climate – of the area where the ship operates.

The examples in this paper are focused on the Belgian situation and legislation. Nevertheless, the overall principles of the followed methodology can be generally applied. In this way, estuary traffic is potentially applicable in other coastal areas and may offer an alternative hinterland connection for other ports.

References

Bačkalov, I. (2010). Probabilistic safety of estuary vessels based on nonlinear rolling in wind and waves, *Transactions RINA*, Vol 152, Part A1, *International Journal of Maritime Engineering*, Jan-Mar 2010.

Belgisch Staatsblad / Moniteur Belge (2007). Koninklijk besluit betreffende binnenschepen die ook voor niet-internationale zee-reizen worden gebruikt / Arrêté royal relatif aux bateaux de navigation intérieure qui sont aussi utilisés pour effectuer des voyages non internationaux par mer. BS/MB, 16.03.2007, N. 2007 – 1187, p. 14699-14711

Bureau Veritas (2010). Rules for the Classification of Inland Navigation Vessels – March 2010 Edition. <http://erules.veristar.com> (last access on 12 November 2011).

De Beck, V. (2007). *Influence of the local wave climate on the results of the risk analysis for estuary vessels*. Dissertation submitted for obtaining the academic degree of Master in Engineering: Electromechanics, option Maritime Technology. Ghent University.

European Parliament and Council of the European Union (2006). Directive of the European Parliament and of the Council of 12 December 2006 laying down technical requirements for inland waterway vessels and repealing Council Directive 82/714/EEC' (2006/87/EC). Official Journal of the European Union, 30.12.2006, L389/1-260.

Hofman, M. and Bačkalov, I. (2005). Weather criterion for seagoing and inland vessels - Some new proposals, Proceedings of *International Conference on Marine Research and Transportation*, ICMRT'05, University of Naples "Federico II", 2005, pp. 53-62.

Lloyd's Register (2008). Rules & Regulations for the Classification of Inland Waterways Ships'.

Port Authority Zeebrugge (2011), Uw Wereld Onze Haven - Jaarverslag 2010, 47 pp, p. 29.

http://www.poz.be/sites/all/files/MBZ_NED_jaarverslag2010.pdf (last access: 12 November 2011)

Promotie Binnenvaart Vlaanderen. De Vlaamse waterwegen onderverdeeld in klassen. http://www.binnenvaart.be/nl/waterwegen/kaart_5klassen.html (last access on 12 November 2011).

RSD (2009). Multimodaal Actieplan RSD in Europees perspectief', Rijn-Schelde Delta Samenwerkingsorganisatie, Bergen op Zoom. http://www.rsdelta.org/nl/UserFiles/Documenten/Mobiliteit/Multimodaal_actieplan/advies_notaMMAjuni2009.pdf (last access on 12 November 2011).

Truijens, P., Vantorre, M. and van der Werff, T. (2006). On the design of ships for estuary service. *Transactions RINA, Part A2 - International Journal of Maritime Engineering (IJME)* 148, p. 1-15.

Vantorre, M., Vandevorde, B., De Schrijver, M., Smits, H., Laforce, E., Mesuere, M., Heylbroeck, B., Wackenier, B., Claeysens, P., Van Steen, J., Van Rompuy, F., van der Werff, T. and Calluy, L. (2006). Risk analysis for inland vessels in estuary service. *Proceedings 31st PIANC Congress*, Estoril, Portugal. 10 pp.

Verelst, K. (2006).. Determination of a Directional Correlation for wave height and wave direction for Estuarine Traffic', Flanders Hydraulics Research, Antwerp.

Vlaamse Hydrografie. Meetnet Vlaamse Banken. (not accessible; replaced by <http://www.meetnetvlaamsebanken.be/default.aspx?Page=Map> (last access on 12 November 2011)).