

Space layout and energy performance

Parametric optimisation of space
layout for the energy performance
of office buildings

Tiantian Du

Space layout and energy performance

Parametric optimisation of space
layout for the energy performance
of office buildings

Tiantian Du



21#15

Design | Sirene Ontwerpers, Véro Crickx

Cover image (background) | *Along the River During the Qingming Festival*, painted by the Song dynasty painter Zhang Zeduan (1085–1145)

ISBN 978-94-6366-435-6

ISSN 2212-3202

© 2021 Tiantian Du

This dissertation is open access at <https://doi.org/10.7480/abe.2021.15>

Attribution 4.0 International (CC BY 4.0)

This is a human-readable summary of (and not a substitute for) the license that you'll find at: <https://creativecommons.org/licenses/by/4.0/>

You are free to:

Share — copy and redistribute the material in any medium or format

Adapt — remix, transform, and build upon the material

for any purpose, even commercially.

This license is acceptable for Free Cultural Works.

The licensor cannot revoke these freedoms as long as you follow the license terms.

Under the following terms:

Attribution — You must give appropriate credit, provide a link to the license, and indicate if changes were made. You may do so in any reasonable manner, but not in any way that suggests the licensor endorses you or your use.

Unless otherwise specified, all the photographs in this thesis were taken by the author. For the use of illustrations effort has been made to ask permission for the legal owners as far as possible. We apologize for those cases in which we did not succeed. These legal owners are kindly requested to contact the author.

Space layout and energy performance

Parametric optimisation of space
layout for the energy performance
of office buildings

Dissertation

for the purpose of obtaining the degree of doctor
at Delft University of Technology
by the authority of the Rector Magnificus, prof.dr.ir. T.H.J.J. van der Hagen
chair of the Board for Doctorates
to be defended publicly on
Tuesday, 06 July 2021 at 12:30 o'clock

by

Tiantian DU
Master of Architecture, Harbin Institute of Technology, China,
born in Liaocheng, China

This dissertation has been approved by the promotor.

Composition of the doctoral committee:

Rector Magnificus,	chairperson
Prof.dr.ir. A.A.J.F. van den Dobbelsteen	Delft University of Technology, promotor
Dr.ir. S.C. Jansen	Delft University of Technology, copromotor
Dr. M. Turrin	Delft University of Technology, copromotor

Independent members:

Prof.dr. L.C.M. Itard	Delft University of Technology
Prof.dr. K. Steemers	University of Cambridge
Prof. Dr.-Ing. P. Geyer	Technical University of Berlin
Dr. H.T. Remøy	Delft University of Technology
Prof. dr.ir. A. Boerstra	Delft University of Technology, reserve member

Acknowledgements

People always say that PhD is a long journey, and one might need so long time to finish it. I would say, it is not only long, but also tough, in which there are traps, floors, and beasts. I cannot forget the nights when I struggled and finally decided to give up all I had had, and started to enter a new field to pursue a doctoral degree. I cannot forget the days when I concentrated myself in the office doing experiments and even did not remember to have meals. I cannot forget all the research roads I walked on alone at the beginning, but luckily to have so many friends to go through together. In China, there is a prevalent saying to describe the highest level of learning knowledge. That is “*In the crowd once and again, I look for her in vain. When all at once I turn my head, I find her here where lantern light is dimly shed*” (众里寻他千百度，蓦然回首，那人却在灯火阑珊处). Like doing research, after many twists and turns, you learnt, and grew up, and then suddenly enlightened, and finally achieved the success. Whenever you looked back, all pay was worth it, no matter sweat, tears, or the incredible efforts you made. I am happy that I am now almost reaching this point. However, all these achievements are not my own credits, and all of you should be credited. I know that without you, my friends, let me call you all friends here, I cannot make it. Hereby, I want to say thank you to all of you here who ever supported me, help me, and shared with me.

First of all, I want to show my great gratitude to my promotor **Sir. Prof. Andy van den Dobbelsteen**. Thank you for offering me an opportunity to join the team and being a PhD candidate work with you. You are a role model of a diligent and rigorous researcher to PhD students. Thank you for the discussion whenever I had pretty challenging questions. Thank you for reviewing our papers, which usually makes you still work at midnight. Thank you for trusting and supporting me when I was challenged. It would not be possible to finish this dissertation without your guidance, support, and encouragement. All I can say is, thanks!

I want to acknowledge my two female co-promoters and supervisors **Sabine Jansen** and **Michela Sabine**. It is so great to have the two ladies helping me during the long PhD journey. I will never forget the time when both of you reviewed my papers at night, at weekend, even on flights. You have built a life model for me to be a female researcher in academia. Sabine, I owe you many thanks for teaching me the knowledge of energy performance, and helping me solve problems that I met in my PhD. Every time I met with a problem, you always sincerely helped me out. Every

time I received your detailed comments, I felt lucky to have you. From you, I learnt how to be a rigorous researcher. Your enthusiasm in work and sincere character is the best part that I could expect from a promoter. Michela, please accept my endless gratitude for bringing me to the world of computational design. You are the most hard-working person that I have ever met. I still kept the scene of our three-hour meeting in my mind, which is one of the most unforgettable moment in my life. From you, I learnt how to continue research when meeting with lots of uncertainty. Also, thank you for offering me the chance to talk with industry, supervising master students, and assisting with conference organisation. Especially, thanks for teaching me how to supervise student. I saw how master students like you.

It is my honor to have **Prof.Dr. L.C.M. Itard**, **Prof.Dr. K. Steemers**, **Prof.Dr. -Ing. P. Geyer**, **Dr. H.T. Remøy**, and **Prof.Dr.Ir. A. Boerstra** as my PhD defence committee members.

I would like to express my sincere gratitude to my Master supervisor in China, **Prof. Hongyuan Mei** (梅洪元教授) and **Prof. Jianfei Chen** (陈剑飞教授). Thanks for fully supporting me pursuing a PhD degree in Delft University of Technology. The time that I spent in Harbin Institute of Technology as a student and architect was the most indispensable and unforgettable period in my life, in which I grew up so fast and obtained all kinds of competence for a further research life.

I truly appreciate you, **Prof. Kas Oosterhuis**, for providing me the opportunity to come to TU Delft. I would like to extend my thanks to **Nimish Bitoria**, for your continuous help and also for hosting me in your house in Sydney.

Big thanks to **Francesco De Luca**, for our collaboration on daylighting simulation with Honeybee and Ladybug. **ESTECO**, especially **Gabriele Degrassi**, thanks for every quick response and technical help with modeFRONTIER. **Aytac Balci**, thanks for your generous help with RenderFarm, and your extra work on Fridays and weekends to help me. **Nienke Blaauw** from BK, thanks for helping formatting the final layout of the thesis. **Dr. Eleonora Brembilla**, I sincerely thank you for help with daylighting and shading simulation. Without your help, I could not finally finish my simulation model. **Martin Tenpierik** and **Regina Bokel**, thanks for your time and help with EnergyPlus. Raquel Viula, I appreciate your help with Radiance. **Samuel Vries**, from TU Eindhoven, thank you for suggestions on the simulation of the shading system. I owe thanks to you, **Andrea Fumagalli**. Thank you for believing in me and choosing your graduation topic from my research direction. It is my honour to be your supervisor for your master graduation project and it was a lovely experience to work with you.

My best Dutch friend, **Nick ten Caat**, I like the time we shared about music and life, especially the dark time during lockdown. Great thanks for helping me with the Dutch summary. I would also like to express my gratitude to all my colleagues, **Tatiana Armijos Moya, Federica Marulo, Pedro de la Barra Luegmayer, Hamza Hamida**, the luckily healthy group during pandemic, for sharing the nice time together in O1 West 250, the lovely PhD office with 'pets'. Thank you, **Yu-chou Chiang, Emeline Lin, Ahmed Felimban, Marco Ortiz Sanchez, Marjolein Overtoom, Tess Blom, Lia Tramontini, Michiel Fremouw, Tanya Tsui, Zoheir Haghighi** for sharing lunch time together. The shared food and talks with international background during our lunch time is the part that I will miss the most. Thank **Miktha Alkadri, Phan Anh Nguyen, Berk Ekici, Cemre Çubukçuoğlu** for sharing the experience in simulation, optimisation and computational design. I want to say thank you to my Chinese colleagues in AET, **Nan Bai, Ding Yang, Frank Pan, Xiao Guo, Xiaoyu Du, Eric Ding**, and the nice time and dinners we shared together left me such wonderful memory.

Dadi Zhang, my paranymp, thank you for helping me every time I asked. You are a lovely girl and deserves a perfect life. Special thanks go to **Bo Song**, for all daily helps during my PhD journey. You are the 'mom' of PhDs in AET. Also, thanks for the drinks and food that you prepared for me. It is so great to have you as a friend. Thank my friends in Hyperbody, **Veronika Laszlo, Arwin Hidding, Jia-Rey Chang**. It is you guys around me that make my start in the Netherlands friendly and pleasant.

It is so awesome of you, **Prof.Dr. H.Peter Hofstee**. Thanks for inviting Jian and me for nice dinners every time you flew from US to Delft. From you, I understood how things look like from a computer scientist point of view. Looking forward to talk to you next time.

Thank you, my team partners from PUBG Mobile, **Ling Jia** (the happiest girl that I have met), **Jiefang Ma** (Sister Mao, the bravest fighter in the team). Although my right hand was ruined, I learnt the importance of team work from the game, as well as how to cooperate effectively and efficiently. My confidantes from Zumba courses, **Lingling Lao, Mingjuan Zhao**, thanks for your accompany and the time we danced together. The virtual Zumba dance is the most special and happiest thing during pandemic. **Hongjuan Wu**, my dearest sportive girl, especially thank you for opening your door at my darkest moment. Love you.

Thanks a millions my great buddies from 'Wolf group', **Yu Xin, Zhijie Ren, Xing Li, Yue Zhao, Zhaokun Guo, Xiang Fu, Lingling Lao, Zixuan Zheng**, for every interesting night we spent together, drinking, chatting, playing games. I enjoy the time when all of us were there. Special thanks go to **Shengzhi Xu**, for the daily help and code assistance. BTW, you were the best driver at Tenerife. **Peng Lin, Jianping Wang**,

Zixun Liu, Dan Cheng, Yanze Yang, every talk with you is nice experience. You always shared very helpful and interesting topics with me, which broadened my vision and knowledge.

Juan Yan, Mei Liu, Taozhi Zhuang, Yan Song, every night that we spent together was always the most energetic and loud night. I cannot thank you enough. Yanchen Sun, Anxiao Zhang, Shi Xu, Yuan Li, Xin Du, Chuan Sun, Na Chen, Yan Liu, Meng Meng, Fengnian Tian, Yi Xia, great to have dinners with you. Tao Lv, Yang Qu, Guangliang Chen, Jintao Yu, it is my pleasure to have you swimming together in Delft.

My bestie **Chunlong Jiang**, and my homie **Zaining Tao**. Thank you for the support you gave me every time, and also every nice dinner. It is hard to find words to express my gratitude.

COVID-19 changed my life, and also changed my attitude to life. I realised the heaviest value from friends. It is not only helping each other, but also accompany, share, support, understanding, encouragement, trust, and even only a smile. There are so many friends I met these years, and I would like to express my great gratitude to **all of you**. Once again, thanks!

My dearest family, **Dad, Mom, Weiwei, Lingling**, and my three cute nieces (**Zixuan, Ziyu, Youxuan**), thanks for the endless and unconditional love. Thank you for standing on my side for every decision I made, even though you did not know whether the decisions were good or not.

My love, **Jian Fang**, my 'bro'. Thank you for cheering me up every time and allowing me to be a little and happy girl. Being together with you is the happiest time in my life. If you still need an answer from me formally, my answer is: 'Yes, I do'.

Tiantian Du

July 1st, 2021

Delft, the Netherlands

Contents

List of Tables	15
List of Figures	17
List of Abbreviations	19
Summary	21
Samenvatting	25

1 Introduction 29

1.1	Background	30
1.1.1	Space layout design and energy performance	30
1.1.2	Performative computational architecture	31
1.1.3	Office building	32
1.1.4	Conclusion	33
1.2	Research framework	33
1.2.1	Problem statement	33
1.2.2	Research objectives	33
1.2.3	Research questions	34
1.3	Research methodology	36
1.4	Scientific and societal relevance	38

2 Effects of Architectural Space Layouts on Energy Performance: A Review 41

2.1	Introduction	42
2.2	Mechanism for How Space Layouts Affect BEP	44
2.2.1	Different Occupancy and Comfort Requirements Between Functions	44
2.2.2	Daylighting	45
2.2.3	Natural Ventilation	45
2.2.4	Control of the Heating, Cooling, Ventilation and Lighting System	46

2.3	Methodology for Studying the Effects of Space Layouts on BEP	46
2.3.1	Proposed Methodology for Studying the Effects of Space Layouts	50
2.3.2	An Example of the Review Procedure for Each Article	53
2.4	Effects of Space Layouts on Energy Use	58
2.4.1	Effects on the Energy Use for Space Heating and Cooling	58
2.4.2	Effects on the Energy Use for Lighting	62
2.4.3	Effects on the Energy Use for Ventilation	63
2.5	Effects of Space Layouts on Occupant Comfort	64
2.5.1	Effects on Thermal Comfort	64
2.5.2	Effects on Visual Comfort	66
2.6	Conclusions and Recommendations	67
2.6.1	Isolated Effects of Space Layouts on BEP	67
2.6.2	The Influence of Other Parameters	68
2.6.3	Recommendations	69
3	Effect of Space Layouts on the Energy Performance of Office Buildings in Three Climates	75

3.1	Introduction	76
3.2	Investigated space layouts and climates	78
3.2.1	Reference building and investigated space layouts	78
3.2.2	Investigated climates	80
3.3	BEP assessment of layouts	80
3.3.1	Procedure for integrating daylighting simulation with energy simulation	81
3.3.2	Simulation model and constructions	82
3.3.3	Daylighting simulation and artificial lighting system	84
3.3.4	Energy simulation	87
3.4	Results and analysis	89
3.4.1	Comparison of energy demand	90
3.4.2	Comparison of the final energy	94
3.4.3	Discussion	95

3.5	Sensitivity analysis of design parameters	97
3.5.1	Sensitivity analysis for different WWRs	97
3.5.2	Sensitivity analysis for different U values	99
3.5.3	Overall conclusion on the sensitivity analysis	100
3.6	Conclusions, recommendations and limitations	100
3.6.1	Conclusions	100
3.6.2	The building physics behind finding the optimal space layout	101
3.6.3	Recommendations for building designers and owners	101
3.6.4	Recommendations for further research	102
3.6.5	Limitations	103
4	Gaps and Requirements for Automatic Generation of Space Layouts with Optimised Energy Performance	109

4.1	Introduction	110
4.1.1	Automatic generation with optimised energy performance	112
4.1.2	Research questions	113
4.1.3	Selection of references	114
4.2	Literature review on G-EPO	115
4.2.1	Methodology of G-EPO	118
4.2.2	Generated layouts and layout representation method	119
4.2.3	Design variables	120
4.2.4	Objectives of optimisation	120
4.2.5	Energy performance calculation method	120
4.2.6	Optimisation algorithm	121
4.2.7	Energy performance improvement and conclusions	121
4.3	GSL method: categorisation and combination with optimisation	122
4.3.1	Design requirements for layout functionality	126
4.3.2	GSL methods categorisation	126
4.3.3	Evaluation of the 7 GSL methods	134
4.3.4	Optimisation of GSL for layout functionality	137
4.4	Requirements for EPO regarding the combination with GSL	138
4.4.1	Requirements for energy performance assessment	138
4.4.2	Requirements for energy performance optimisation	140

4.5	Conclusions, summaries and recommendations	144
4.5.1	Conclusions	144
4.5.2	Summaries	145
4.5.3	Recommendations	146
5	Relationship analysis and design optimisation of space layouts to improve the energy performance of office buildings	155

5.1	Introduction	156
5.2	Method for DOE and optimisation	159
5.2.1	Workflow of the method	159
5.2.2	Generation of space layout	162
5.2.3	Energy and daylighting performance assessment	166
5.2.4	Automation of generation and assessment	168
5.3	Proposed design indicators	170
5.3.1	Design indicators for the whole layout	173
5.3.2	Design indicators for each function	176
5.4	DOE and relationship analysis	179
5.4.1	DOE algorithm and results	179
5.4.2	Method for relationship analysis	180
5.4.3	Analysis of the relationship between energy demands	180
5.4.4	Analysis of the relationship between energy demands and design indicators for the layout	183
5.4.5	Analysis of the relationship between energy demands and design indicators for each function	185
5.4.6	Comparison between four types of design indicators	188
5.5	Optimisation for minimising energy demands	189
5.5.1	Single-objective optimisation for minimising each energy demand	190
5.5.2	Multi-objective optimisation for minimising all energy demands	196
5.6	Conclusions and recommendations	199
5.6.1	Conclusions	199
5.6.2	Recommendations	201

6 Design Recommendations for Energy-Efficient Space Layout 207

- 6.1 **Introduction** 207
- 6.2 **General recommendations** 209
- 6.3 **Function allocation** 211
 - 6.3.1 Potential effect 211
 - 6.3.2 Theoretical explanation of the effect 211
 - 6.3.3 Recommendations 212
- 6.4 **Internal partitions between rooms** 213
 - 6.4.1 Potential effect 213
 - 6.4.2 Theoretical explanation of the effect 214
 - 6.4.3 Recommendations 214
- 6.5 **On optimisation of space layouts together with building geometry** 215
- 6.6 **On optimisation of space layout together with the building envelope** 215
- 6.7 **On optimisation of space layouts when including functional requirements** 216
- 6.8 **Designing for different climates** 217
 - 6.8.1 Potential effect 217
 - 6.8.2 Theoretical explanation of the effect 218
 - 6.8.3 Recommendations 219
- 6.9 **Optimisation when taking into account energy system efficiency** 220
 - 6.9.1 Potential effect 220
 - 6.9.2 Theoretical explanation of the effect 220
 - 6.9.3 Recommendation 221

7 Conclusions 223

- 7.1 **Introduction** 223
- 7.2 **Answers to the research questions** 224
 - 7.2.1 Sub-questions 224
 - 7.2.2 Main research question 232

7.3	General conclusion	234
7.3.1	Most important findings	234
7.3.2	Scientific contribution	235
7.3.3	Societal contribution	235
7.4	Discussion	236
7.4.1	Limitations and challenges	236
7.4.2	Recommendations for future development	238
7.5	Outlook	240
	Curriculum Vitae	243
	List of Publications	244

List of Tables

- 2.1 Keywords for searching references. 43
- 2.2 Collection of the studies focusing on the effects of space layouts on building energy performance (BEP). 48
- 2.3 Classification of design variables affecting BEP, regarding their relationship with space layout design. 50
- 2.4 Energy demand comparison between the layouts with same occupancy, adapted from [42]. 56
- 2.5 Annual energy demand comparison between three layouts, adapted from [64]. 59
- 2.6 Annual final energy comparison between cell and open layouts, adapted from [65]. 60
- 2.7 Energy demand comparison between the selected four layouts, adapted from [67]. 61
- 2.8 Comparison of the fresh air volume supplied by natural ventilation, adapted from [63]. 63
- 2.9 Energy performance comparison between the selected layouts, adapted from [68]. 65
- 2.10 Hourly thermal discomfort comparison between layouts, adapted from [69] (TDP: thermal discomfort penalty. The higher the thermal penalty, the worse the thermal performance). 66
- 3.1 Details of walls, floors and glazing used for the layouts in three climates 84
- 3.2 Control strategy for the shading system 87
- 3.3 Maximum internal gains of different spaces 88
- 3.4 Energy demand of all layouts in the three climates 90
- 3.5 The sum of the final energy for heating, cooling and lighting for the three climates 94
- 3.6 Maximal and minimal energy demand and the maximum difference (%) among 11 layouts with the WWR of 20% and 60% in three climates 98
- 3.7 U values of exterior wall and glazing for poor insulated buildings in the three climates 99
- 3.8 Maximal and minimal energy demand and the maximum difference (%) among 11 layouts with U values for poor insulated buildings with the WWR of 40% in three climates 99
- 4.1 Keywords used for searching references 114
- 4.2 Studies relevant to G-EPO 116
- 4.3 Analysis of references to elaborate different GSL methods 124
- 4.4 Requirement for layout functionality 126
- 4.5 Classify studies into different GSL methods 133
- 4.6 Compare the properties of GSL methods 135
- 4.7 Design variables for energy performance optimisation, relating to space layout design 140
- 5.1 Maximum internal gains of different functions 167
- 5.2 Detailed information for simulation 167
- 5.3 Radiance parameters used for daylighting simulation 168

5.4	Design variables and their domains	169
5.5	Outputs and constraints	170
5.6	Nomenclature	172
5.7	The regression coefficients of three rounds of regression analysis for heating, cooling, and lighting demand respectively, between energy demand of the layout and energy demands of different functions	183
5.8	The resulting improvement in each energy demand from single-objective optimisations	191
6.1	Classification of building design parameters affecting BEP, regarding their relationships with space layouts	207
6.2	Requirement for layout functionality	216
7.1	Classification of building design parameters affecting BEP, regarding their relationships with space layouts	238

List of Figures

- 1.1 Relevant research domains 30
- 1.2 Research methodology and outline of the thesis 35
- 2.1 Relevant research domains 43
- 2.2 Different boundaries for BEP assessment, adapted from [76] 52
- 2.3 Five layouts with a boundary of 12 m × 12 m in [42] 53
- 2.4 Three layouts modelled with different thermal zoning strategies in [64]. The interior partitions divide the layout into different thermal zones. 59
- 2.5 Cell and open layouts in [65]. The interior partitions divide the layout into different thermal zones. 60
- 2.6 Four different layouts with the same geometry in [67]. Different colours represent different thermal zones. 61
- 2.7 Three layouts with similar WWRs in [68]. The interior partitions divide the layout into different thermal zones. 64
- 2.8 Examples of two layout sets in [69] (left: layout with one floor, right: layout with two floors). The interior partitions divide the layout into different thermal zones. 65
- 3.1 Space layout of the reference building, adapted from [20] 78
- 3.2 Proposed 11 variants of the reference layout 79
- 3.3 Procedure to integrate daylighting simulation with energy simulation 82
- 3.4 Simulation models for one layout 83
- 3.5 Test points and lighting zones for lighting system control (the two middle rooms do not have daylighting) 86
- 3.6 Occupancy schedule for different functions 89
- 3.7 Heating demand of layout-c and layout-k without the shading system for Amsterdam 92
- 3.8 Energy demand of each function in different locations 95
- 3.9 Simulation models with WWR of 20% and 60%. 97
- 4.1 Framework of G-EPO 112
- 4.2 Relevant research domains of G-EPO 113
- 4.3 Workflow of G-EPO, used in [9,21,23–26] 118
- 4.4 Workflow of G-EPO, used in [10,22,27–31] 119
- 4.5 Two methods of G-EPO 122
- 4.6 Generation process in [44] (also the source of images) 127
- 4.7 Generation process used in [24,25] (also the source of images) 128
- 4.8 Generation process used in [52] (also the source of images) 129
- 4.9 Generation process in [23] (also the source of images) 130
- 4.10 Generation process in [56] (also the source of images) 130
- 4.11 Generation process in [58] (also the source of images) 131

- 4.12 Collected space layout and colour labelled map in [59] (also the source of images) 132
- 4.13 Three different zoning methods, adapted from [116] 139
- 4.14 Proposed alternative methodology for G-EPO 147
 - 5.1 Integration procedure of the method for DOE and optimisation 159
 - 5.2 Workflow of the method for DOE and optimisation 160
 - 5.3 Procedure to create layouts 163
 - 5.4 Ignored scenario for splitting the layout. 165
 - 5.5 An example layout illustrating the calculation of design indicators 171
 - 5.6 Matrix of correlation coefficients and scatter plots, for energy demands and ff-ratio for the layout 181
 - 5.7 Matrix of correlation coefficients and scatter plots, for energy demands and ff-orientations for the layout 184
 - 5.8 Matrix of correlation coefficients, between energy demands of each function and ff-function-orientations 186
 - 5.9 Matrix of correlation coefficients, between energy demands of canteen and all design indicators for canteen 187
 - 5.10 Matrix of correlation coefficients, between energy demands of canteen and all design indicators for canteen 188
 - 5.11 The layout with the minimum lighting demand, the layout with the moderate lighting demand, and the layout with the maximum lighting demand, resulting from the optimisation for minimising lighting demand 192
 - 5.12 The layout with the minimum heating demand, the layout with the moderate heating demand, and the layout with the maximum heating demand, resulting from the optimisation for minimising heating demand 193
 - 5.13 Layouts in which no room orients the West and satisfy layout area constraint, resulting from the optimisation for minimising heating demand 194
 - 5.14 The layout with the minimum cooling demand, the layout with the moderate cooling demand, and the layout with the maximum cooling demand, resulting from the optimisation for minimising cooling demand 195
 - 5.15 3D chart and history charts for the three objectives of the multi-objective optimisation, with only feasible layouts (i.e. satisfying the layout area constraint) 198
- 6.1 11 layouts tested in Chapter 3 209
- 6.2 The layouts with the minimum cooling, heating and lighting demand, resulting from the single-objective optimisations in Chapter 5 213
- 6.3 The biggest maximum differences in heating and cooling demands caused by function allocation for the three climates shown in Chapter 3 218
- 7.1 Main studies of the research 223

List of Abbreviations

(In order of appearance)

— BEP	building energy performance
— WWR	window-to-wall ratio
— PCA	Performative computational architecture
— DOE	Design of Experiments
— HVAC	heating, ventilation and air conditioning
— PMV	predicted mean vote
— ASHRAE	American Society of Heating, Refrigerating and Air-Conditioning Engineers
— TAS	Thermal Analysis Software
— IDA ICE	IDA Indoor Climate and Energy
— AV	air volume from natural ventilation
— IS	illuminance set-point satisfaction
— DL	indoor daylight level
— SL	shading level
— TDP	thermal discomfort penalty
— Cfb	Temperate oceanic climate
— Dfb	Humid continental climate
— BSk	Cold semi-arid climate
— Dwa	Humid continental climate
— Csb	Temperate Mediterranean climate
— GSL	automatic generation of space layouts
— G-O	automatic generation of space layouts combined with optimisation
— EP	energy performance assessment of space layouts
— EPO	energy performance optimisation of space layouts
— G-EPO	automatic generation of space layouts with optimised energy performance
— GH	Grasshopper
— mF	modeFRONTIER
— DOE	Design of Experiments
— ULH	Uniform Latin Hypercube

— SOM	Self-Organising Maps
— ff-ratio	façade area to floor area ratio
— floor-orientation	floor area ratio per orientation e.g. floor-S
— façade-orientation	façade area ratio per orientation, e.g. façade-S
— ff-orientation	façade area to floor area ratio per orientation, e.g. ff-S
— hd-orientation	height to depth ratio per orientation, e.g. hd-S
— floor-function-orientation	floor area ratio per function per orientation, e.g. floor-office-S
— façade-function-orientation	façade area ratio per function per orientation, e.g. façade-office-S
— ff-function-orientation	façade area to floor area ratio per function per orientation, e.g. ff-office-S
— hd-function-orientation	height to depth ratio per function per orientation, e.g. hd-office-.

Summary

Architectural design greatly influences building energy performance (BEP), and energy-efficient design is therefore often studied. Architectural space layout also can affect BEP. However, only a few of the numerous studies on energy-efficient design considered the effect of space layout. Within these studies, the isolated effect of space layout on the BEP has hardly have been analysed systematically.

The framework of Performative Computational Architecture (PCA) had been proven to be effective to improve BEP. PCA includes form generation, performance evaluation, and computational optimisation. With this framework, the building's geometry and material properties are parametrised, and the performance is assessed for different combinations of design parameters. It aims to find the proper parameters that satisfy the defined objectives. This method can include the generation and assessment of space layouts. However, only a few studies have tried to combine the automatic generation of space layout with energy performance optimisation; nor the systematic analysis of the effects and relations between space layout and energy performance.

Hence, the aim of this research is to investigate how space layout affects BEP, and to develop a computational method to support such investigation and the optimisation of space layout in order to improve BEP. The scope of this research is focussed on office buildings. This thesis addresses the following research questions:

- 1 *How does space layout affect building energy performance and what are the relevant parameters, based on current research?*
- 2 *What is the isolated effect of space layout on building energy performance?*
- 3 *What are the current gaps and requirements for the automatic generation of space layout with energy performance optimisation?*
- 4 *How to computationally optimise space layout to improve the building energy performance?*
- 5 *What is the relationship between space layout and energy performance?*

6 *How to apply the results of this research to practice?*

Several approaches were used to address these research questions, including literature review, computational simulation, optimisation, Design of Experiments (DOE), and relationship analysis.

A literature review was conducted in Chapter 2, and the studies relevant to space layout and energy performance were collected. It was found that many studies on either space layout or energy performance could be found, but only a few studies combined both. Based on the review of the references collected, three topics were studied and conclusions were drawn: (1) the mechanism of how space layout affects BEP was identified; (2) the related design variables that affect BEP were identified and classified; (3) based on the relatively small number of papers that combined energy performance and space layout, a preliminary conclusion could be drawn on the potential effect of space layout on BEP.

In Chapter 3 a study was performed to identify the isolated effect of space layout, i.e. to investigate how much the energy performance can be improved solely by space layout design. For this aim, 11 layouts were proposed with a different allocation of various functions, given the same external boundaries of the floorplan and the same internal partitions. Hence, the difference in BEP was caused by the different function allocation alone. The energy demands were investigated for three climates (temperate, cold and tropical), with three typical cities (Amsterdam, Harbin and Singapore). A dynamic simulation was conducted for the energy performance assessment, which included the integration of daylight simulation with energy (heating, cooling and lighting demand) simulation. For each layout and each climate, two situations were simulated: one having no shading system, and another one assuming an exterior screen for shading. Based on the simulation results, it was found that the lighting demand is affected most by the layout variance. The maximum difference (difference between the highest demand and the lowest demand, divided by the highest demand) was found in Harbin, being 46% for the situation without shading and 35% with shading. The maximum difference in heating demand was smaller, and the highest value occurred in Amsterdam, being 11% for the situation without shading and 18% for the situation with shading. The maximum difference in cooling demand was the smallest, and the highest value occurred in Amsterdam, i.e. 8% for the situation without shading and 11% for the situation with shading. In addition to the separate demands, the effect on total final energy was also studied, assuming certain efficiencies for the production of lighting, heating and cooling. The maximum difference in total final energy was found to be 8% for the layouts studied, both without and with shading system occurring in Amsterdam.

Another literature review was conducted in Chapter 4, focussed on studies relevant to the automatic generation of space layout and including energy performance optimisation. Based on 66 studies investigated, seven methods for the automatic generation of space layout were categorised and evaluated. An analysis was proposed for the requirements of space layout generation and of energy performance optimisation regarding their combination.

In Chapter 5, the relationship between space layout and BEP was studied and a computational optimisation of energy performance was carried out. For this aim, a computational method was proposed according to the PCA framework of form generation, performance assessment and computational optimisation. This method includes: a method to parametrically generate schematic space layouts featuring energy related variables; and an assessment method integrating daylighting simulation and energy simulation in a temperate climate; additionally it uses advanced computational methods to generate and analyse the results.

To investigate the relationship between space layout and BEP, a Design of Experiments (DOE) was performed with the proposed method, providing 500 evaluations, of which the results were used to investigate the relationship. Correlation analysis and regression analysis were conducted based on DOE results to identify the relationship between space layout and energy performance. The relationship analysis shows that regarding the effect on energy demands, the façade area to floor area ratio (ff-ratio) of corner rooms are more influential than the ff-ratio of the other locations; the location of offices is more influential than the location of other functions; ff-ratio (which is related to the compactness of the layout) is more influential than the other types of design indicator.

With the same computational method to generate schematic space layouts and assess energy performance, optimisations were run with the objectives to minimise heating, cooling and lighting demands. The optimisation studies showed that the resulting improvement (same as the maximum difference) was up to 54% for the lighting demand, 51% for heating demand and 38% for cooling demand. The optimisations confirm the conclusions of chapter 3. This improvement is much higher than the improvement found in the 11 layouts studied in chapter 3, which shows the optimisation was able to find more diverse space layouts, or, which can be explained by the fact that the external boundary was also a variable.

Finally, the results and conclusions of the previously described studies were translated into design recommendations for energy-efficient space layout in Chapter 6. Following the classification of design variables of space layout as introduced in Chapter 2.

As was shown with the analysis of all the results in chapter 3 and 5, some general relationships are found between design variables related to space layout and energy performance. These are described in the conclusions of chapter 5. Façade area to floor area ratio is proven to be significantly influential on building heating, cooling and lighting demands, in terms of the entire layout and also for each function. Furthermore, corner rooms show a stronger correlation with the energy demand than other locations within a layout. Awareness on these relations is important and is expected to be useful for the designers. However, it does not suffice in order to predict the best space layout in terms of energy performance. This is because the best space layout highly depends on the tested functions and the related properties, and more explanation can be found in Section 7.2.1. Thus, for each specific design case a computational analysis and optimisation might still be needed, also in consideration of the specificities of the design case and its functions.

To sum up, the thesis has proven that space layout can significantly affect the BEP, and can thus be used to improve it. The lighting demand is especially highly affected by the space layout chosen. The relationship between space layout and energy performance was studied and several indicators were found to be influential. However, it is difficult to predict the best space layout in terms of energy performance, as the best layout depends on the requirements and properties of functions required in a floorplan. Hence, a case by case computational analysis is needed to improve or optimise a space layout for a given set of functions.

Samenvatting

Architectonisch ontwerp heeft een significante impact op de energieprestaties (EP) van gebouwen en energie efficiëntie is daarom een veel bestudeerd onderwerp. Ruimtelijke indeling van gebouwen kan ook van invloed zijn op de EP. Echter nemen maar enkele van de talloze studies rondom energie efficiënt ontwerpen de ruimtelijke indeling in beschouwing. Binnen deze kleine selectie studies is het geïsoleerde effect van ruimtelijke indeling op de EP nog maar nauwelijks systematisch geanalyseerd.

Performative Computational Architecture (PCA) is een onderzoekskader dat bewezen effectief is om de EP van gebouwen te verbeteren. Elementen van PCA zijn: vorm genereren, prestatie evaluatie en gecomputeriseerde optimalisatie. PCA kan worden ingezet om de gebouwgeometrie en de materiaaleigenschappen te parametriseren en kan de prestaties van verschillende combinaties ontwerpparameters berekenen. Daarbij tracht PCA de geschikte parameter-combinaties te isoleren die de gedefinieerde doelen behalen. Deze methode kan ook worden toegepast om ruimtelijke indelingen te produceren en te berekenen. Echter, tot op heden hebben nog maar enkele studies getracht om geautomatiseerde productie van ruimtelijk ontwerp te combineren met EP optimalisatie, laat staan een systematisch analyse van de effecten en relaties tussen ruimtelijke indeling en EP.

Het doel van dit onderzoek is te bepalen hoe ruimtelijke indeling de energieprestatie van gebouwen beïnvloed en om een gecomputeriseerde methode te ontwikkelen die ruimtelijke indeling kan optimaliseren ten behoeve van de energieprestatie. Kantoorgebouwen vormen het onderwerp van deze studie. Voor dit onderzoek zijn de volgende onderzoeksvragen geformuleerd:

- 1 *Hoe beïnvloedt de ruimtelijke indeling de energieprestatie van gebouwen en wat zijn de relevante parameters volgens bestaande onderzoeken?*
- 2 *Wat is het geïsoleerde effect van de ruimtelijke indeling op de energieprestatie van gebouwen.*
- 3 *Wat zijn de huidige vraagstukken en vereisten voor ontwerp-automatisering van ruimtelijke indeling ter energieprestatie optimalisering?*

- 4 *Hoe kan ruimtelijke indeling ter verbetering van energieprestatie computationeel geoptimaliseerd worden?*
- 5 *Wat is de relatie tussen ruimtelijke indeling en gebouw energieprestatie?*
- 6 *Hoe kunnen de resultaten van dit onderzoek worden toegepast in de praktijk?*

Verschillende onderzoeksmethoden zijn toegepast om deze onderzoeksvragen te beantwoorden, waaronder een literatuur review, computer simulatie + optimalisering, Design of Experiments en relatie-analyse.

In hoofdstuk 2 wordt een literatuuronderzoek gepresenteerd waarin de relevante onderzoeken op het gebied van ruimtelijke indeling en energieprestatie zijn verzameld. Voor beiden onderwerpen is veel bestaand onderzoek beschikbaar, echter zijn er maar enkele studies die beide onderwerpen combineren. Op basis van dieper onderzoek naar de relevante publicaties zijn de volgende drie conclusies getrokken: (1) het mechanisme tussen ruimtelijk indeling en EP is geïdentificeerd, (2) de onderzoekvariabelen die de EP beïnvloeden zijn geïdentificeerd en geclassificeerd, en (3) op basis van de beperkt beschikbare publicaties die de twee onderwerpen combineren kunnen voorlopige conclusies op het effect van ruimtelijke indeling op de EP worden geformuleerd.

Hoofdstuk 3 beschrijft een onderzoek waarin het geïsoleerde effect van ruimtelijke indeling op de EP wordt geïdentificeerd, m.a.w.: hoe kan de energieprestatie van gebouwen worden verbeterd enkel door middel van ruimtelijke (her)indeling. Om dit te achterhalen zijn elf ruimte-configuraties voorgesteld waarbij alleen de functies van de verschillende ruimtes werd gewisseld binnen ongewijzigde binnen- en buitenwanden. Deze methode verzekerd dat de gemeten verschillen enkel hun oorzaak vinden in deze functie verschuivingen. De energievragen zijn onderzocht voor drie klimaten (gematigd, koud en tropisch) in drie typerende steden (Amsterdam, Harbin en Singapore). Een dynamische simulatie is toegepast voor de EP berekening, waarbij daglicht simulaties met energiesimulaties voor verwarming, koeling en verlichting zijn geïntegreerd. Voor elke indeling en elk klimaat zijn twee scenario varianten gesimuleerd: zónder zonweringsysteem en met een extern scherm voor zonwering. Op basis van de simulatieresultaten kan worden aangetoond dat de verlichtingsvraag is het meest wordt beïnvloed door variatie in ruimtelijke indeling. Het grootste verschil (verschil tussen hoogste en laagste vraag, gedeeld door de hoogste vraag) is berekend in Harbin: 46% voor de situatie zonder zonwering en 35% met zonwering. De maximale variatie in warmtevraag was kleiner en het grootste verschil werd berekend in Amsterdam, namelijk 11% voor de situatie zonder zonwering en 11% met zonwering. Tot slot was de kleinste variatie waarneembaar

voor de koelvraag en werd nogmaals het maximale verschil berekend in de simulatie voor Amsterdam: respectievelijk 8% en 11% voor de situatie met en zonder zonwering. Naast de separate analyses voor warmte, koeling en verlichting werd ook het totale effect op de finale energievraag gesimuleerd, waarbij bepaalde aannames werden toegepast voor de efficiëntie van de verlichting, verwarming en koeling. Het grootste verschil in deze totaal-simulatie voor alle voorgestelde indelingen, 8%, werd gevonden in Amsterdam voor zowel de situatie met als zonder zonwering.

In hoofdstuk 4 staat een tweede literatuuronderzoek beschreven. In deze studie worden bestaande onderzoeken relevant voor de ontwerp-automatisering van ruimtelijke indeling en energieprestatie optimalisering samengebracht. Op basis van 66 bestaande onderzoeken zijn zeven methoden voor ontwerp-automatisering gecategoriseerd en geëvalueerd. Voor zowel de ontwerp-automatisering van ruimtelijke indeling als de EP optimalisatie is een analyse van de gecombineerde vereisten voorgesteld.

In hoofdstuk 5 wordt de samenhang tussen ruimtelijk indeling en EP bestudeerd door middel van gecomputeriseerde optimalisatie. Om deze samenhang helder te krijgen, is een gecomputeriseerde methode voorgesteld volgens het PCA kader voor vorm-generatie, presentatie berekeningen en optimalisaties. Deze aanpak omvat: een methode om op parametrische wijze een schematische ruimtelijk indeling te genereren aan de hand van energievariabelen, een rekenmethode om daglichtsimulatie en energiesimulatie te integreren in een gematigd klimaat en tot slot past het geavanceerde computergestuurde methodes toe om de resultaten te produceren en analyseren.

Aan de hand van deze voorgestelde methode is een *Design of Experiments (DOE)* uitgevoerd om de relatie tussen ruimtelijke indeling en EP verder te onderzoeken. Dit heeft geleid tot 500 evaluaties waarvan de uitkomsten werden gebruikt om de samenhang te in kaart te brengen. Correlatieanalyse en regressieanalyse zijn toegepast op de DOE resultaten om het verband tussen ruimtelijke indeling en energieprestatie te identificeren. De relatieanalyses toont aan dat de verhouding gevel-vloeroppervlak meer van invloed is op de energievraag in hoekruimtes dan op de overige ruimtes. Ook heeft de locatie van de kantoorfuncties een sterkere invloed dan de locatie van de overige functies. Tot slot kan worden gezegd dat de gevel-vloer ratio meer invloed heeft dan de andere types ontwerpindicatoren.

Met dezelfde voorgestelde methode zijn optimalisaties uitgevoerd met als doel de warmte-, koel- en verlichtingsvraag te verminderen. De optimalisatie tonen aan dat verbeteringen mogelijk zijn tot 54% voor de verlichtingsvraag, 51% voor de warmtevraag en 38 voor de koelvraag. Deze optimalisatie experimenten bevestigen

de conclusies gevormd in hoofdstuk 3. Deze verbeteringen liggen aanzienlijk hoger dan de verbeteringen gemeten voor de elf indelingen in hoofdstuk 3. Dit toont aan dat door middel van optimalisatie, meer gediversifieerde ruimtelijke indelingen geproduceerd worden. Mogelijk kan het verschil ook worden toegekend aan het feit dat de buitengrenzen van het gebouw in de optimalisaties variabel waren.

Tot slot worden in hoofdstuk 6, volgend op de classificering van ontwerpvariabelen voor ruimtelijke indeling geformuleerd in hoofdstuk 2, de resultaten en conclusies van dit onderzoek vertaald naar ontwerpaanbevelingen voor energie efficiënte ruimtelijke indelingen.

Op basis van de resultaatanalyses uit hoofdstuk 3 en 5 zijn enkele algemene relaties gevonden tussen ontwerpvariabelen voor ruimtelijke indeling en energieprestatie. Deze worden verder beschreven in de conclusies van hoofdstuk 5. De analyses tonen aan dat de gevel-vloeroppervlak verhouding het meest van invloed is op de warmte-, koeling en verlichting vraag van het gebouw voor zowel de totale ruimtelijke indeling alsook voor individuele functies. Verder kan worden opgemerkt dat de hoekruimtes een sterkere correlatie vertonen met de energievraag dan de andere locaties binnen een indeling. Inzicht in deze relaties is belangrijk en mogelijk nuttig voor ontwerpers. Echter, is dit niet voldoende om de beste ruimtelijke indeling te voorspellen ten behoeve van de energievraag. Dit komt doordat de meest optimale indeling sterk afhankelijk is van de gekozen functies en de bijbehorende eigenschappen, wat verder toegelicht wordt in sectie 7.2.1. Zodoende zal mogelijk voor elk ontwerp een afzonderlijke gecomputeriseerde analyse en optimalisatie nodig zijn om ook rekening te houden met de specifieke kenmerken van een ontwerpvragestuk en de bijbehorende functies.

Dit onderzoek bewijst dat de ruimtelijke indeling de EP aanzienlijk kan beïnvloeden en zodoende kan worden ingezet om de gebouwprestaties te verbeteren. De verlichtingsvraag is het sterkst beïnvloed door de gekozen ruimtelijk indeling. De samenhang tussen ruimte indeling en energieprestatie is bestudeerd en verschillende invloedrijke factoren zijn gevonden. Het is echter lastig om de beste indeling te voorspellen ten behoeve van de energieprestatie aangezien de beste indeling afhankelijk is van de vereisten en kenmerken van de verschillende functies noodzakelijk in een plattegrond. Mede daardoor is een gecomputeriseerde analyse nodig voor elk afzonderlijk ontwerp om de ruimtelijke indeling te verbeteren ofwel te optimaliseren ten behoeve van een gedefinieerde groep functies.

1 Introduction

The energy consumption in buildings makes up around 40% of the total primary energy consumption in the US and EU [1]. Due to the need for reducing carbon emissions, the demand for energy-efficient building design is urgent. Design of architectural space layout is one of the most important tasks of an architect, dealing with the allocation of different functions within a building, including interior layouts and placement of interior walls. It is also affected by the boundaries, shape or geometry of the building. Studies have shown that space layout design is expected to affect the building energy performance (BEP) and thus can be used to reduce energy demands. However, still relatively little is known about how space layout design affects the BEP, and how to optimise the space layout design to improve energy performance.

The goal of this research is to investigate how space layout affects the BEP, and to develop a computational method for the optimisation of space layout to improve the BEP for office buildings. In order to realise the goal, this thesis presents the following content:

- A detailed literature review of the state-of-the-art knowledge of how space layout affects energy performance and of the relevant design parameters of space layouts (Ch. 2);
- Analysis of the isolated effect of space layout on the building energy performance (Ch. 3);
- A detailed literature review to analyse the gaps and requirements for the automatic generation of space layout with energy performance optimisation (Ch. 4);
- Development of a computational method to optimise space layout design for the improvement of energy performance (Ch. 5);
- An analysis of the relationships between space layout and energy performance (Ch. 5);
- Design recommendations regarding energy-efficient space layouts (Ch. 6).

This introduction chapter presents the background literature study used to formulate the problem statement and research questions, followed by the research framework – including problem statement and research objectives and questions – and the research methodology. It concludes with the scientific and societal relevance of this thesis.

1.1 Background

1.1.1 Space layout design and energy performance

Architectural space layout design is one of the most important architectural design tasks, taking place around ‘scheme design’ and ‘design development’ in the early design phase [2]. In this thesis, space layout is defined as the allocation of different functions within a building, which includes interior layouts and placement of interior walls. It is also affected by the boundaries, shape or geometry of the building.

Studies have shown that, among all phases of the life-cycle, the phase of architectural design presents the highest potential for decreasing the environmental impacts and costs [3]. Space layout design is one of the important tasks in the architectural design phase, and studies have proven that space layout design is promising to improve the BEP. A brief literature review is conducted in the following paragraph regarding recent research on the effect of space layouts.

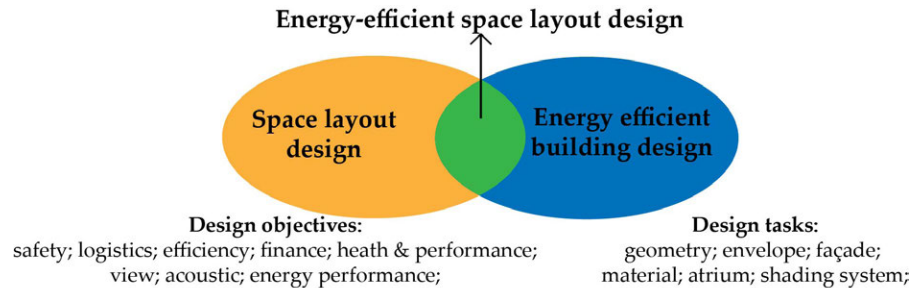

FIG. 1.1 Relevant research domains

Only a few studies [4–13] deal with the combination of space layout design and energy performance. The relevant research domains are shown in Figure 1.1. These studies have shown that space layout can affect the energy use for heating, cooling, lighting and ventilation, as well as the thermal and visual comfort for occupants. For instance, in the study of Musau and Steemers [4], five space layouts of an office building in the UK were simulated and their energy demands were compared, and

there turned out to be a difference¹ of 57% between the highest and lowest heating demand (measured in kWh during a peak winter day). In the study of Yi [9], several layouts with the same boundary for an office building in South Korea were simulated and compared, and the difference in Predicted Mean Vote (PMV) between these layouts was up to 15%.

However, these relevant studies changed not only space layouts, but also the other design parameters simultaneously. For instance, in addition to space layouts, the studies of [4,5] also changed space use density, occupancy, and distribution of workstations; the studies of [7–10] also changed the window-to-wall ratio (WWR). Therefore, these studies show that space layout design is promising to improve the BEP, whereas its isolated effect has not been identified yet. Based on traceable literature, the relationship between space layout and energy performance has been investigated very limitedly.

1.1.2 Performative computational architecture

Performative computational architecture (PCA) is a method supporting the design of high-performance buildings, based on form-finding optimisation at early design stages [14]. It aims to improve the building performance by informing the decisions during the design process by means of performance evaluation. It supports architectural design by allowing designers to explore different design alternatives by gaining awareness of their performance [15]. With PCA, the building's geometry and material properties are parametrised, and designers vary the design parameters to satisfy the design objectives relevant to certain building performance. PCA includes three phases: form generation, performance evaluation, and optimisation [14]. Different design parameters of buildings have been explored for PCA, including geometry, façade, materials, shading, orientation, WWR, etc. Different objectives have been studied, such as energy, daylight, thermal comfort, life cycle cost, logistics, etc. Recent studies have proven that using PCA to optimise BEP helps to reduce the energy demand significantly, as shown in [16].

Evins [16] extensively reviewed studies on computational energy optimisation, and his study reveals a dominant attention to building envelopes, mechanical systems and energy generation. However, among the analysed precedents, space layout

¹ Difference calculated by dividing the difference between the highest demand and lowest demand by the highest demand.

was rarely used. A similar conclusion can be drawn from the review study of Ekici et al. [14], who collected studies on PCA. This review paper shows that, among all the form-finding parameters, the WWR, shading, orientation, window dimension, and building shape are the most commonly used design variables for optimisation. However, among the 100 studies collected, only 6 studies were relevant to space layout design. According to these reviews, it appears that PCA has been studied and applied to different design tasks, while it is rarely applied to space layout design.

Designing space layout with PCA can help to improve the energy performance of the building. Several studies have proven this potential. The study of Dino and Üçoluk [8] optimised space layouts for the improvement of energy and daylighting performance, as well as the functionality of space layout. The study of Rodrigues et al. [10] developed a method to automatically generate space layout and to assess the thermal performance of the layout created. These studies show promising results for improving energy performance by optimising space layout design.

1.1.3 Office building

Offices are one of the most energy consuming building types. According to the survey conducted by Building Performance Institute Europe [17], offices comprise 23% of the useful floor area and 26% of the final energy use among all non-residential buildings for different countries across Europe. Under the 2015 Paris Climate Agreements, the energy use of office buildings needs to be reduced to nearly zero energy. Space layout design is expected to help saving a considerable part of energy in office buildings.

Office buildings have typical functions, i.e. offices, meeting rooms, break rooms, core and staircases. These functions have different requirements for comfort, in terms of thermal, acoustic and visual properties. For instance, the set-points for cooling and heating vary between different functions. Also, the required illuminance levels vary between different functions. It is the difference in comfort requirements between functions that makes the function allocation matter for the energy performance of the whole layout. Therefore, for this research office buildings were chosen to test how space layout design can impact the BEP.

1.1.4 **Conclusion**

Studies have shown that space layout design can significantly impact the BEP. However, few studies have been done, and its isolated effect on the BEP has not been identified yet. Additionally, the relationship between space layout and energy performance has hardly been analysed. PCA has been proven to be effective to improve the BEP, whereas there are only several studies that applied PCA to space layout design in combination with energy performance. The results of these studies show that it is promising to apply PCA to space layout design to improve energy performance.

1.2 **Research framework**

1.2.1 **Problem statement**

Only a few studies have tried to combine the automatic generation of space layout with energy performance optimisation. These studies have shown that there can be a significant impact. However, it is not clear how space layout design affects the BEP, and space layout design is rarely used for energy performance optimisation compared to other design tasks. Hence, the potential of space layout design to improve building energy performance is not fully identified; especially the isolated effect of changing only space layout is not known. In addition, the general relationship between space layout and energy performance has never been investigated. The method of performative computational architecture is promising in improving building energy performance. However, so far it is much less applied to space layout design compared to the other design tasks.

1.2.2 **Research objectives**

The aim of this research is to investigate how space layout affects building energy performance, and to develop a computational method for the optimisation of space layout in order to improve the building energy performance (BEP) of office buildings.

1.2.3 Research questions

1.2.3.1 Main research question:

How does space layout design affect the building energy performance and how can space layout design be optimised to improve the energy performance of office buildings?

1.2.3.2 Sub-questions:

1 How does space layout affect building energy performance and what are the relevant parameters, based on current research?

The first step of the research is to investigate the current knowledge on how space layouts affect the BEP and to identify the relevant design parameters of space layout, to build the foundation for the following studies.

2 What is the isolated effect of space layout on building energy performance?

After a detailed review of current studies, it was found that most studies mixed space layout design with other design parameters, which made it impossible to identify the isolated effect of space layouts on energy performance. So, new research is needed to identify the isolated effect of space layouts on energy performance. The energy performance involves heating, cooling and lighting demands in this research.

3 What are the current gaps and requirements for the automatic generation of space layout with energy performance optimisation?

Before developing a new computational optimisation method for space layout, the requirements for the generation of space layout with energy performance optimisation need to be identified.

4 How to computationally optimise space layout to improve the building energy performance?

A computational method needs to be developed to support improving the building energy performance by space layout design.

5 What is the relationship between space layout and energy performance?

For a deeper understanding of how space layouts affect the energy performance, the relationship between space layout and energy performance needs to be investigated. In order to analyse this relationship, relevant design indicators, which represent the architectural features of space layout, need to be identified.

6 How to apply the results of this research to practice?

The results and conclusions of this research need to be translated into design recommendations and guidelines for building designers and owners.

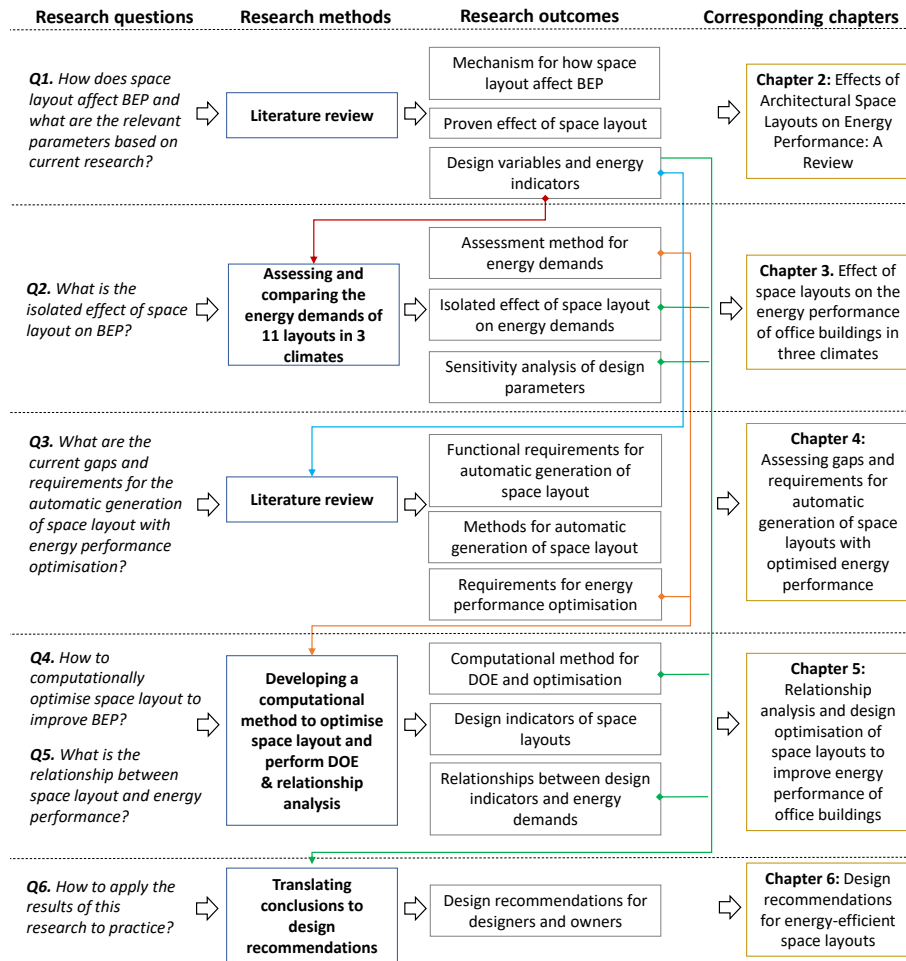

FIG. 1.2 Research methodology and outline of the thesis
 Note: BEP = Building Energy Performance

1.3 Research methodology

As shown in Figure 1.2, the methodology includes five steps: (1) literature review on how space layout affects the BEP and design variables of space layout; (2) assessing and comparing energy demands to identify the isolated effect of space layout; (3) literature review on the requirements for the automatic generation of space layout and energy performance optimisation; (4) developing a computational method to optimise space layout and perform Design of Experiments (DOE), leading to analysis of and insight into the relationship between space layout; (5) finally, translating the conclusions into design recommendations.

1 Literature review on how space layout affects the building energy performance and the design variables of space layout

Regarding the first research question, a literature review was conducted and the results are presented in Chapter 2. The studies relevant to both space layout and energy performance were collected. From these studies, the mechanism of how space layout affects the BEP was determined; the design variables of space layout and the energy indicators for evaluation were identified; finally, the effects of space layout on both energy use and occupant comfort were identified.

2 Assessing and comparing energy demands of 11 layouts in 3 climates

As shown in Chapter 3, in order to identify the isolated effect of space layout, 11 layouts with different function allocations were proposed, keeping the same layout boundary and internal partitions. An assessment method was developed integrating daylighting simulation with energy simulation. The energy demands (heating, cooling and lighting) of the different layouts were simulated and compared for three climates, i.e. temperate, cold and tropical. Additionally, two design parameters, i.e. the window-to-wall ratio (WWR) and thermal transmittance (U value), were tested for their influence on the effect of space layout.

3 Literature review on the requirements for the automatic generation of space layout with energy performance optimisation

Regarding the third research question, a literature review was conducted and the results are presented in Chapter 4. The studies relevant to space layout, energy, and automation were collected; based on the studies collected, the requirements for the automatic generation of space layout with energy performance optimisation were identified.

4 Developing the computational method and performing Design of Experiments (DOE)

This step aims to find the relationship between space layout and energy performance, as well as develop a computational method to optimise space layout to improve energy performance. As shown in Chapter 5, a computational method was developed, including the parametric generation of space layout variants, energy and daylighting performance assessment. The method was implemented using software that allow the automation of the iterative loops. Design of Experiments (DOE) was performed based on the computational method, and the relationship between space layout and energy demands was identified based on the DOE results. In order to identify the relationships, four types of design indicators were proposed. For each design variant generated, its values were calculated with regard to both layout and each function. The energy performance trends were then analysed in relation to the variations of each indicator. Finally, the computational method was also used for the optimisation of a space layout, with the objectives of minimising heating, cooling and lighting demands.

5 Translating conclusions to design recommendations for designers and owners

In order to help architectural designers and building owners design energy-efficient space layouts, the results and conclusions of this research were translated into design recommendations, as shown in Chapter 6.

1.4 Scientific and societal relevance

The scientific relevance is explained from the perspectives of different research disciplines. From the perspective of energy performance, the thesis contributes to identify the effect of space layout on the BEP, which helps to thoroughly explore the effective measures to improve a building's energy performance. The thesis explicitly extracts the knowledge of how space layout affects the BEP, and this helps designers and researchers to better understand space layout design from the perspective of energy. From the perspective of PCA, the thesis expands the application of PCA to space layout design.

As mentioned in the introduction, there is a need for sustainable energy systems for the built environment and thus for energy-efficient building design. The thesis provides new inspiration and an operative method for architects to design space layout driven by the goal of improving energy performance. It allows designers to explore large numbers of design variations with consciousness on the consequences for energy performance, while being eventually inspired toward new design directions. It helps to extend the role of architects as energy designers, and can also raise the attention of building owners and designers to space layout design for both building renovation and new building design.

References

- [1] X. Cao, X. Dai, J. Liu, Building energy-consumption status worldwide and the state-of-the-art technologies for zero-energy buildings during the past decade, *Energy Build.* 128 (2016) 198–213. <https://doi.org/10.1016/j.enbuild.2016.06.089>.
- [2] D. Lobos, D. Donath, The problem of space layout in architecture: A survey and reflections, *Arquitetura Rev.* 6 (2010) 136–161. <https://doi.org/10.4013/arq.2010.62.05>.
- [3] N. Kohler, S. Moffatt, Life-cycle analysis of the built environment, *Ind. Environ.* 26 (2003) 17–21. <http://bases.bireme.br/cgi-bin/wxislind.exe/iah/online/?IsisScript=iah/iah.xis&src=google&base=REPDISCA&lang=p&nextAction=lnk&exprSearch=19108&indexSearch=ID> (accessed December 3, 2018).
- [4] F. Musau, K. Steemers, Space Planning and Energy Efficiency in Office Buildings: The Role of Spatial and Temporal Diversity, *Archit. Sci. Rev.* 51 (2008) 133–145. <https://doi.org/10.3763/asre.2008.5117>.
- [5] F. Musau, K. Steemers, Space Planning, Ventilation and Energy Efficiency in Offices, *Int. J. Vent.* 8 (2009) 9–22. <https://doi.org/10.1080/14733315.2006.11683828>.
- [6] C.B. de Souza, S. Alsaadani, Thermal zoning in speculative office buildings: discussing the connections between space layout and inside temperature control, in: *Proc. 1st Build. Simul. Optim. Conf.*, Loughborough, UK, 2012; pp. 417–424. <http://www.ibpsa.org/proceedings/BSO2012/6C1.pdf> (accessed April 11, 2017).
- [7] H. Poirazis, Å. Blomsterberg, M. Wall, Energy simulations for glazed office buildings in Sweden, *Energy Build.* 40 (2008) 1161–1170. <https://doi.org/10.1016/j.enbuild.2007.10.011>.
- [8] I.G. Dino, G. Üçoluk, Multiobjective Design Optimization of Building Space Layout, Energy, and Daylighting Performance, *J. Comput. Civ. Eng.* 31 (2017) 04017025. [https://doi.org/10.1061/\(ASCE\)CP.1943-5487.0000669](https://doi.org/10.1061/(ASCE)CP.1943-5487.0000669).
- [9] H. Yi, User-driven automation for optimal thermal-zone layout during space programming phases, *Archit. Sci. Rev.* 59 (2016) 279–306. <https://doi.org/10.1080/00038628.2015.1021747>.
- [10] E. Rodrigues, A.R. Gaspar, Á. Gomes, Automated approach for design generation and thermal assessment of alternative floor plans, *Energy Build.* 81 (2014) 170–181. <https://doi.org/10.1016/j.enbuild.2014.06.016>.
- [11] T. Dogan, C. Reinhart, P. Michalatos, Automated multi-zone building energy model generation for schematic design and urban massing studies, in: *IBPSA Esim Conf.*, Ottawa, Canada, 2014. <http://www.ibpsa.org/proceedings/eSimPapers/2014/5B.2.pdf> (accessed March 23, 2017).
- [12] R. Baušys, I. Pankrašovaite, Optimization of architectural layout by the improved genetic algorithm, *Civ. Eng. Manag.* 13 (2005) 37–41. <https://doi.org/10.1080/13923730.2005.9636328>.
- [13] J. Michalek, R. Choudary, P. Papalambros, Architectural layout design optimization, *Eng. Optim.* 34 (2002) 37–41. <https://doi.org/10.1080/03052150214016>.
- [14] B. Ekici, C. Cubukcuoglu, M. Turrin, I.S. Sariyildiz, Performative computational architecture using swarm and evolutionary optimisation: A review, *Build. Environ.* 147 (2019) 356–371. <https://doi.org/10.1016/j.buildenv.2018.10.023>.
- [15] M. Turrin, P. Von Buelow, R. Stouffs, Design explorations of performance driven geometry in architectural design using parametric modeling and genetic algorithms, *Adv. Eng. Informatics.* 25 (2011) 656–675. <https://doi.org/10.1016/j.aei.2011.07.009>.
- [16] R. Evins, A review of computational optimisation methods applied to sustainable building design, *Renew. Sustain. Energy Rev.* 22 (2013) 230–245. <https://doi.org/10.1016/j.rser.2013.02.004>.
- [17] M. Economidou, *Europe's Buildings Under the Microscope: Executive Summary*, 2011.

2 Effects of Architectural Space Layouts on Energy Performance: A Review

This chapter is adapted from a journal paper published on 29 Feb 2020: T. Du, S. Jansen, M. Turrin, A. van den Dobbelen, Effects of Architectural Space Layouts on Energy Performance: A Review, Sustainability. 12 (2020) 1829. <https://doi.org/10.3390/su12051829>.

ABSTRACT As one of the most important design tasks of building design, space layout design affects the building energy performance (BEP). In order to investigate the effect, a literature review of relevant papers was performed. Ten relevant articles were found and reviewed in detail. First, a methodology for studying the effects of space layouts on BEP were proposed regarding design variables, energy indicators and BEP calculation methods, and the methodologies used in the 10 articles were reviewed. Then, the effects of space layouts on energy use and occupant comfort were analysed separately. The results show that the energy use for heating, cooling, lighting and ventilation is highly affected by space layouts, as well as thermal and visual comfort. The effects of space layouts on energy use are higher than on occupant comfort. By changing space layouts, the resulting reductions in the annual final energy for heating and cooling demands were up to 14% and 57%, respectively, in an office building in Sweden. The resulting reductions in the lighting demand of peak summer and winter were up to 67% and 43%, respectively, for the

case of an office building in the UK, and the resulting reduction in the air volume supplied by natural ventilation was 65%. The influence of other design parameters, i.e., occupancy and window-to-wall ratio, on the effects of space layouts on BEP was also identified.

2.1 Introduction

Architectural design highly affects the building energy performance (BEP), and energy-efficient design is therefore often studied [1]. Space layout design is one of the most important tasks in architectural design, taking place around the stages of ‘scheme design’ and ‘design development’ in the early design phase [2,3]. In this paper, the architectural space layout is defined as the allocation of different spaces, and it is decided based on the placement of interior partitions as well as exterior walls. The design variables of space layout design include function allocation, space dimension (width, length, height), space form, interior partition and interior opening. Moreover, the layout boundary can also be the design variables of the space layout design with a non-fixed boundary as a consequence of changing interior and exterior walls. These will be explained in more detail in Section 2.3.1.1.

There are plenty of studies exploring the effects of geometry on BEP, such as the studies on boundary dimensions [4–8], forms [9–12] and orientations [4,5,13]. Most studies have been reviewed in [1]. These studies imply that space layouts affect BEP greatly, as geometry can be a consequence of the space layout design within a non-fixed layout boundary. Moreover, different functions have different comfort requirements such as thermal comfort and lighting levels, which result in different internal gains. Hence, if spaces can be mapped to the proper orientations and locations that have sufficient daylight and natural ventilation within a building, the building is expected to require less energy demand in total.

Although architectural space layout is expected to highly affect BEP, it is rarely included in the studies on energy-efficient building design. Numerous studies exist on energy-efficient design, and most of them focus on geometry [11,14], envelope [15,16], façade [17,18], material [19,20], atrium [21,22] and shading systems [23,24]. On the other hand, researchers have been working on space layout design for decades [25,26]; however, they mainly focused on other design objectives rather than energy performance. These objectives include safety [27,28], logistics [29,30], efficiency [31,32], finance cost [33,34], occupant health and performance [35,36],

view connection [37,38] and acoustics [39,40]. These two research domains, space layout design and energy-efficient building design, are shown in Figure 2.1. The overlapping area of the two domains, i.e., energy-efficient space layout design, is the focus of this paper. This paper aims at the effects on BEP caused by changing space layouts, without considering the possible influence on the indirect cost of the building, such as space usability and workability.

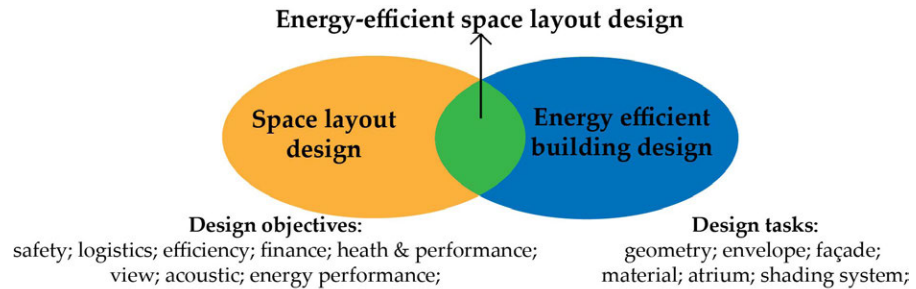

FIG. 2.1 Relevant research domains

The review was performed by searching in engines of Google Scholar, ScienceDirect, Web of science and the library of the Delft University of Technology. The keywords used to search the relevant references include two types of terms: space layout and energy, as shown in Table 2.1. Moreover, we limited the discipline to architectural design.

TABLE 2.1 Keywords for searching references.

Terms (space layout)		Terms (energy)
Space layout	and	Energy use
Space planning		Energy consumption
Space allocation		Energy performance
Interior layout		Energy saving
Floor plan		Heating
		Cooling
		Lighting
		Ventilation

The paper is structured as follows: first, as background, the mechanism for how space layouts affect BEP is formulated. Second, the methodology for studying the effects of space layouts on BEP is proposed as the guideline to review each relevant article; then, the procedure for reviewing one article is shown as an example and each article is reviewed following the same procedure. Next, the methodologies used in the relevant articles are analysed and compared. Third, the effects of space layouts on energy use and occupant comfort are identified and analysed separately.

2.2 Mechanism for How Space Layouts Affect BEP

It is important to analyse the mechanism for how space layouts affect BEP before the detailed review. Based on the studies found with the keywords of space layout terms and energy terms, we identify the following factors that determine how space layouts affects BEP below.

2.2.1 Different Occupancy and Comfort Requirements Between Functions

Different layouts accommodate different occupant densities. For instance, an open office has a higher occupant density than a cellular office [41,42]. Space layouts also affect the occupant behaviour, such as attending an activity or changing the location where the activity happens, as shown in [43]. Different occupancy has different internal gains and also different requirements for comfort purpose, such as the total amount of ventilation. Eventually, the different occupancy affects the energy demand. Additionally, different functions have various levels of comfort requirements. For instance, as shown in the Dutch standard of NEN 16798-1 [44], the minimum operative temperature for space heating is 20 °C for sedentary activity like in offices, while the value is 16 °C for standing-walking activity like in corridors. As recommended in [45], the illuminance set-point is 500 lux for offices and 300 lux for meeting rooms, while the value is 200 lux for canteens and 150 lux for staircases. Thus, different comfort requirements between functions affect the whole energy demand eventually.

2.2.2 Daylighting

The effect of daylighting can be explained with the following three points. First, different layouts impart different levels of daylight into the building. This is proven by the studies on the daylighting performance of the building with atriums [46–48] and courtyards [49]. These studies show that by changing the shape, location and dimension of atriums or courtyards, the daylighting performance of the whole building changes. Secondly, an appropriate space layout combined with the glazing design boosts the application of daylight within a building. For instance, the function with a higher lighting requirement can be located near the south façade for more solar radiation, and the function with a lower lighting requirement can be located in the middle or near the north façade to make a concession for other spaces, in the Northern Hemisphere. Thirdly, the interior partitions also affect the application of daylight, considering the visual comfort of occupants, as shown in [50].

2.2.3 Natural Ventilation

By combining with openings, an appropriate space layout distributes fresh air to the rooms based on their demands. For instance, the function with higher occupancy can be located near the windward façade and the function with a lower ventilation requirement, like a storage or facility room, can be located near the leeward façade. The study of [51] shows that by changing the shape of interior partitions for corridors, a higher mean flow velocity can be obtained, increasing up to 33%, as well as a steadier airflow within the building. Moreover, by changing the location and dimension of buffer spaces, such as a courtyard [52], solar chimney [53], atrium [54] and light-well [55], the natural ventilation within buildings changes significantly. The study of [56] showed that the building with a better space connection and integration has a higher natural ventilation velocity. For instance, the corridor and dining room have high permeability and accessibility, and the measured data shows that they also have higher ventilation velocities. Another study [57] showed that a vernacular building with courtyards, patios and gardens has a better microclimate than a modern building without buffer spaces, in terms of air temperature, relative humidity and wind velocity.

2.2.4 Control of the Heating, Cooling, Ventilation and Lighting System

Different space layouts are suitable for different types of control for space heating, space cooling, ventilation and lighting systems. For instance, the individual control is more suitable for a cellular office than an open office, as shown in [58,59]. The blind control is more difficult in an open office than in a cellular office, as shown in [60]. Different control types result in different energy performance. Moreover, the indicators relevant to daylighting and natural ventilation can be used as indicator for controlling, for instance, the availability of daylight for lighting system control [61] and air quality and thermal comfort for ventilation system control [62]. Using dynamic control based on the available daylight and natural ventilation, the effects of space layouts on BEP are boosted.

2.3 Methodology for Studying the Effects of Space Layouts on BEP

There are plenty of studies that only studied the effects of geometry (such as boundary dimensions, building forms and orientations) on BEP without changing interior layouts. They are not included in the detailed review below, and the following detailed review is limited to the studies that also changed interior layouts. Ten articles were found focusing on the intersection of space layouts and energy performance, as shown in Table 2.2. First, in Section 2.3.1, a methodology for how to study the effects of space layouts on BEP is proposed, which was used as the guideline for reviewing the 10 articles. Then, the procedure for reviewing one article is shown as an example, and the other articles were reviewed following the same procedure. It is unnecessary to show the procedures for all articles, as similar procedures were used. After that, the 10 articles were reviewed following the same procedure as shown in Section 2.3.2 and their methodologies are analysed and compared in Section 2.3.3. Moreover, the resulting effects of space layouts on BEP derived from the 10 articles are analysed and compared in Section 2.4 and 2.5.

Following the methodology proposed in Section 2.3.1 and the example procedure in Section 2.3.2, the 10 articles were reviewed in terms of climates, building types, floor areas, constant parameters, design variables, energy indicators, BEP calculation method, BEP calculation tools, multi-domain integration and resulted biggest reduction. All this information is shown in Table 2.2. In order to quantify the effects of space layouts on BEP, the term of reduction (%) was used, referring to the highest value minus the lowest value, and divided by the highest value. The reduction means the percentage of the studied indicator that the best layout reduces compared to the worst layout. The values shown in the column of the resulting biggest reduction in Table 2.2 are based on the analysis in Section 2.4 and 2.5.

TABLE 2.2 Collection of the studies focusing on the effects of space layouts on building energy performance (BEP).

Ref.	Author	Year	Location	Cli- mate	Build- ing type	Floor Area (m ²)	Constant parameters	Design variables	
[42]	Musau & Steemers	2008	Garston, UK	Cfb	office	144 (1floor)	boundary dimension, form and orientation, heating and cooling set-points, WWR, material, opening for ventilation, occupancy schedule	function allocation, interior partition, lighting and ventilation requirements, occupancy, number and distribution of workstations	
[63]	Musau & Steemers	2009	Garston, UK	Cfb	Office	144 (1 floor)	Same as in [42]	closed or opened doors, state of opening windows, the others are the same as in [4]	
[64]	Souza & Al-saadani	2012	London, UK	Cfb	office	658 (1 floor)	boundary dimension, form and orientation, material, WWR	function allocation, interior partition, air exchange rate, internal gains	
[65]	Poirazis et al.	2008	Gothenburg, Sweden	Dfb	office	6177 (6 floors)	boundary dimension, form and orientation, occupancy schedule, material, infiltration rate	function allocation, interior partition, occupancy, lighting power density, illuminance requirement, equipment power density, ventilation rate, WWR	
[67]	Dino & Ucoluk	2017	Ankara, Turkey	BSk	library	7200 (4-8 floors)	material, internal gains from equipment, occupancy schedule	function allocation, interior partition, WWR, boundary dimension and form	
[68]	Yi	2016	Seoul, South Korea	Dwa	Office	936 (1 floor)	boundary dimension, form and orientation, material, occupancy schedule	function allocation, interior partition, WWR	
[69]	Rodrigues et al.	2014	Coimbra, Portugal	Csb	apartment	141-163 (1floor); 158-189 (2 floors)	Material, schedule, occupancy, internal gains	boundary dimension and form, function allocation, interior partition, WWR, type and size of shading system	
[70]	Dogan et al.	2014	/	/	/	/	Boundary dimension, form and orientation, material, internal gains	inter zone heat flows	
[71]	Baušys & Pankrašovaite	2005	/	/	/	136-214 (minimal: 119, 1floor)	Material, occupancy, schedule	function allocation, interior partition, WWR	
[33]	Michalek et al.	2002	/	/	/	165 (minimal, 1 floor)	boundary dimension, form and orientation, material, internal gains	function allocation, interior partition, WWR	

Note: '/': the information is not shown in the reference. WWR: window to wall ratio; HVAC: heating, ventilation and air conditioning; PMV: predicted mean vote; ASHRAE: American Society of Heating, Refrigerating and Air-Conditioning Engineers; TAS: Thermal Analysis Software; IDA ICE: IDA Indoor Climate and Energy; H: heating demand or final energy; C: cooling demand or final energy; L: lighting demand or final energy; AV: air volume from natural ventilation; IS: illuminance set-point satisfaction; DL: indoor daylight level; SL: shading level; TDP: thermal discomfort penalty.

The tested climates are identified based on the Köppen-Geiger climate classification as shown in [72]. Cfb: Temperate oceanic climate; Dfb: Humid continental climate; BSk: Cold semi-arid climate; Dwa: Humid continental climate; Csb: Temperate Mediterranean climate.

	Energy indicators (unit)	BEP calculation period	BEP calculation tools	Multi-domain integration	Resulted biggest reduction
	heating demand (kWh/day) cooling demand (kWh/day) lighting demand (kWh/day)	peak winter and summer day	-lighting: Lightscape -thermal: TAS -natural ventilation: TAS	daylight + thermal; natural ventilation + thermal;	H: 57% C: 11% L (winter): 43% L (summer): 67%
	air volume from natural ventilation (m ³)	peak winter and summer day	-lighting: Lightscape -thermal: TAS -natural ventilation: TAS	Same as in [42]	AV: 65%
	heating demand (kWh/m ² a) cooling demand (kWh/m ² a)	One year	EnergyPlus	No	H: 52% C: 24%
	final energy for heating (kWh/m ² a) final energy for cooling (kWh/m ² a) final energy for lighting (kWh/m ² a)	One year	IDA ICE 3.0 [66]	No	H: 14% (30% WWR) C: 57% (30% WWR) L: 4.1 kWh/m ² a (40% WWR)
	heating demand (kWh/day) cooling demand (kWh/day) lighting demand (kWh/day) Illuminance set-point satisfaction	four seasonal days	OpenStudio (EnergyPlus)	No	H: 19% C: 20% L: 10% IS: 27%
	PMV Indoor daylighting level (daylight illuminance, lux) shading level	One year	Ecotect (no longer available)	No	PMV: 13% DL: 11% SL: 2%
	thermal discomfort penalty based on air temperature (°C)	One year	EnergyPlus	No	TDP: 33% (1 floor), 29% (2 floors)
	heating demand (/) cooling demand (/)	One year	No mention	No	/
	final energy of heating (/) final energy of lighting (/)	One year	Steady state calculation	Daylight + artificial lighting	/
	final energy of lighting (/) final energy of heating (/) final energy of cooling (/)	One year	Steady state calculation (based on recommendation of ASHRAE)	Daylight + artificial lighting	/

2.3.1 Proposed Methodology for Studying the Effects of Space Layouts

Based on the methodologies used in the 10 articles (Table 2.2) and also the mechanism for how space layouts affect BEP, a methodology is proposed for systematically studying the effects of space layouts on BEP. It is also used as the guideline to review and analyse the 10 articles.

2.3.1.1 Design Variables

In order to analyse the isolated effects of space layouts, the design variables influencing energy balance are classified, regarding their relationships with space layouts, as shown in Table 2.3.

TABLE 2.3 Classification of design variables affecting BEP, regarding their relationship with space layout design.

Design variables of space layouts (with a non-fixed boundary)		Space properties		Envelope design
Space layout design (within a fixed boundary)		Functional requirements	Use of spaces	
<ul style="list-style-type: none"> – Function allocation – Space dimension – Space form – Interior partition – Interior opening 	<ul style="list-style-type: none"> – Boundary dimension – Boundary form – Orientation 	<ul style="list-style-type: none"> – Set-point temperature for heating – Set-point temperature for cooling – Lighting requirements (e.g., illuminance) – Ventilation requirement (e.g., air flow rate) – Control types 	<ul style="list-style-type: none"> – Occupancy, activity and schedule – Internal gains from appliances and lighting – Opening state of windows and doors 	<ul style="list-style-type: none"> – Thermal transmittance – Window area – Window location – Glazing type – Shading type and effectiveness – Air tightness

Note: 'Function allocation' means allocating different functions to different rooms. 'Control types' means the different types of the control for lighting, ventilation, heating and cooling systems. 'Appliances' include the used devices, equipment and machines.

Firstly, the design variables belonging to space layouts include function allocation, space dimension, space form, interior partition and interior opening [33,42,68,73]. Secondly, if space layouts are designed within a non-fixed layout boundary, the boundary dimension, form and orientation can also be changed consequently [69,74].

Thirdly, the space properties that influence BEP include functional requirements and the use of spaces: functional requirements mean that if different functions are located in different spaces, they have different requirements for heating, cooling, lighting and ventilation; the use of spaces refers to the profiles of internal gains resulting from occupants, lighting, appliances, etc. Lastly, the envelop design of buildings is important for BEP, and it influences the effects of space layouts on BEP. A systematic methodology for studying the effects of space layouts on BEP should first keep the other design variables constant and only change the design variables of space layouts in order to assess the isolated effects of space layouts on BEP, and after this, by adding the other design variables one by one, evaluate their influence on the effects of space layouts.

2.3.1.2 Energy Indicators

Energy indicators differ in three ways: energy end-use, assessment period and system boundary. They are classified and explained below:

- The energy end-use in buildings include space heating, space cooling, water heating, lighting, ventilation, electricity for appliances, etc. [75]. The more energy end-use is included, the more exhaustive the resulted effects of space layouts are.
- Regarding the assessment period, energy can be calculated on an annual basis or for a shorter time period, like a summer day and a winter day. The assessment period is decided depending on the located climate zone. For instance, if the heating demand is dominant compared to the cooling demand in one climate, the heating period is more representative and the BEP calculation should be calculated at least for the heating period.
- There are different system boundaries for the BEP assessment, including the conditioned space perimeter of a building or building unit, building site, and outside building site [75]. The corresponding energy inputs regarding the system boundaries are energy demand (or energy needs), final energy and primary energy, respectively, as shown in Figure 2.2. The used assessment boundary should be clearly stated.



FIG. 2.2 Different boundaries for BEP assessment, adapted from [76]

2.3.1.3 BEP Calculation Methods

The way in which the space layout affects BEP highly depends on how daylighting and natural ventilation is used in buildings. Thus, in order to assess the effect, the BEP calculation with multi-domain integrations is necessary, like integrating daylighting and natural ventilation with energy assessment. Moreover, the type of BEP calculation methods highly influences the accuracy of BEP results.

- **Multi-domain integrations for BEP calculations:** As mentioned in Section 2.2, the daylighting and natural ventilation in buildings is highly affected by space layout design. The possible multi-domain integrations include calculating the reduction of artificial lighting as a result of the available daylighting and calculating the reduction of mechanical ventilation as a result of the available natural ventilation. The possibility of integrations depends on whether the located climate zone prefer daylighting or natural ventilation. Integrating multi-domain influences is also needed to accurately predict BEP for building simulations, as shown in [77]. However, no single simulation tool can simulate all physical domains accurately, thus, exchanging information between different simulation software across multi-domains is needed, as shown in [78,79]. Some tools can help to do this, such as a functional mock-up unit in EnergyPlus [79] and a co-simulator for TRNSYS and ESP-r [80].
- **Types of BEP calculation methods:** There are mainly two different types of BEP calculation methods: the steady-state calculation and the dynamic simulation. The steady-state calculation, in principle, is based on energy balance without considering dynamic effects for a given moment [81]. It can also be used for a long time, like one month or a whole season, by taking into account the dynamic effects with empirically determined gain and loss utilisation factors. The dynamic simulation calculates energy balance with a short time step, typically 15 minutes or one hour, taking into account the heat stored in and released from the mass of buildings. The steady-state method does not take into account or roughly calculate the dynamic response of the

building thermal mass, and its results are less accurate. National norms are usually based on the steady-state method. A large number of tools are available for dynamic simulation nowadays, such as TRNSYS [82], EnergyPlus [83], IDA Indoor Climate and Energy (IDA ICE) [66], ESP-r [84], and Clim2000 [85].

2.3.2 An Example of the Review Procedure for Each Article

The 10 articles in Table 2.2 are reviewed systematically following the proposed methodology shown in Section 2.3.1. The methodologies of previous articles analysed in Section 2.3.3 and the results shown in Section 2.4 and 2.5 are fully based on the systematically review of the 10 articles. In order to explain how each article is reviewed, an example of the procedure for reviewing one article is presented in this section. The other articles are reviewed following the same procedure as shown in this example. In order to avoid unnecessary similar content, the review procedures of the other articles are not presented.

The study of Musau and Steemers [42] is taken as an example, as it provided detailed information on energy simulation and clear results. This article investigated the energy demand for heating, cooling and lighting with five different office layouts in Garston, the UK, in a temperate oceanic climate (Cfb). The five layouts are Hive (open plan), Den, Club, Combi and Cell, as shown in Figure 2.3. Occupancy differs between layouts. We extract the following information from the original article, following the methodology shown in Section 2.3.1, in order to identify the isolated effects of space layouts.

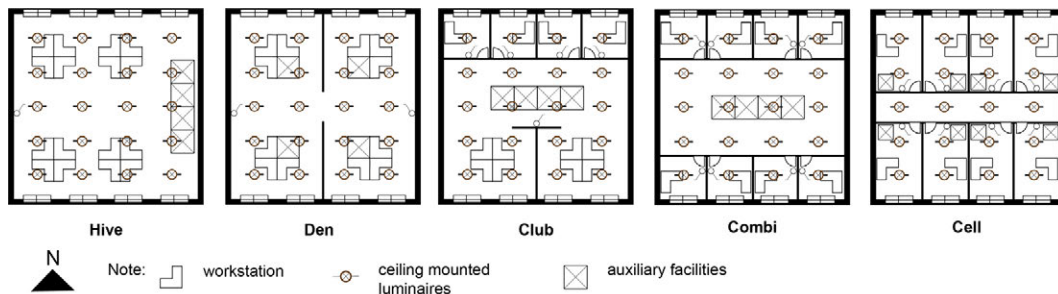

FIG. 2.3 Five layouts with a boundary of 12 m × 12 m in [42]

2.3.2.1 Identifying Design Variables

In order to identify the isolated effects of space layouts, each article needs to be analysed and selected for the cases which only changed the design variables of space layout design while keeping the other variables, such as materials and window-to-wall ratio (WWR), constant. Regarding the design variables influencing BEP as shown in Table 2.3, the following variables were changed in this article:

- **Space layout design:** function allocation and interior partition.
- **Functional requirements:** lighting and ventilation requirements. The used control types of lighting and ventilation systems were related to the distribution of occupants. For instance, when a room had no occupants, the lighting and ventilation supply was reduced to the lowest level. Different layouts had different distributions of occupants, resulting in different requirements for lighting and ventilation.
- **Use of spaces:** occupancy and number of workstations. Different layouts had different numbers of occupants and workstations.

2.3.2.2 Identifying Constant Parameters

Except for design variables, it is also necessary to identify the constant parameters used in each article, in order to compare the results from different articles. Regarding the design variables influencing BEP as shown in Table 2.3, the following design parameters were kept constant in this article:

- **Layout boundary:** boundary dimension, boundary form and orientation.
- **Functional requirements:** temperature set-points for heating and cooling.
- **Use of spaces:** occupancy schedule.
- **Envelope design:** WWR (30% for the north and south façade, and 0% for the east and west façade), materials (including the reflectance and conductance of roofs, floors and external walls) and size and location of openings for ventilation (800 mm wide door shutters at the bottom of each door).

2.3.2.3 Identifying Energy Indicators and the BEP Calculation Method

Energy indicators need to be identified for each article, in order to classify the resulting effects of space layouts from different articles. The used BEP calculation method in each article influences the accuracy of results. In this article, the used indicators include heating demand, cooling demand and lighting demand in the peak winter (21st of December) and peak summer (12th of July). This study was performed with dynamic simulation, using Thermal Analysis Software (TAS) for energy and natural ventilation simulation and Lightscape for daylighting simulation. The effects of daylighting and natural ventilation were integrated with energy simulation. The required artificial lighting was reduced based on the daylighting simulation result, and the required mechanical ventilation was reduced based on the natural ventilation simulation result, and these were used as inputs into the energy simulation.

2.3.2.4 Selecting Cases and Analysing Results

Most articles present multiple cases and some of them mixed the design variables of space layouts with other variables. In order to identify the isolated effects of space layouts, the cases in each article should be strictly selected. Among all cases presented in this article, we selected and compared only the cases with the same number of occupants. The results of the cases with the same occupancy are reorganised and shown in Table 2.4. Table 2.4 shows the isolated effects of space layouts as well as the influence of occupancy, as follows:

- **Isolated effects of space layouts:** The heating demand differs highly between layouts with low occupancy. The biggest reduction in the heating demand is 57%, which is between the layouts with six occupants. In contrast, the reduction in the cooling demand is relatively small (11%).
- **Influence of occupancy on the effects of space layouts on BEP:** With the increase of occupancy, the reductions in heating and cooling demands decrease apparently. The values of the heating and cooling demands are almost the same in different layouts when layouts are highly occupied (12 occupants). This is because when most rooms are highly occupied, the interior partitions that enable different energy requirements in different rooms have less influence.

TABLE 2.4 Energy demand comparison between the layouts with same occupancy, adapted from [42].

Space layouts	Heating demand in peak winter	Lighting demand in peak winter	Cooling demand in peak summer	Lighting demand in peak summer
a) space layouts with 4 occupants (kWh/day)				
Hive	4	14	14	3
Combi	5	10.5	13	1
Cell	7	8.5	13	1
Reduction (%)	43%	39%	7%	67%
b) space layouts with 6 occupants (kWh/day)				
Den 1	3	14	19	4
Den 2	7	8	17	2
Club	6	12	18	3
Combi	4	12	18	2
Cell	6	10	19	3
Reduction (%)	57%	43%	11%	50%
c) space layouts with 8 occupants (kWh/day)				
Hive	3	15	23	3
Combi	3	14	25	2
Cell	3	15	25	4
Reduction (%)	0%	7%	8%	50%
d) space layouts with 12 occupants (kWh/day)				
Hive	3	15	32	3
Den	3	15	33	3
Club	3	15	34	2
Reduction (%)	0%	0%	6%	33%
Biggest reduction	57%	43%	11%	67%

2.3.3 Methodologies Used in Previous Studies

Following the same procedure shown in Section 2.3.2, the other nine articles were reviewed and the information is shown in Table 2.2. The methodologies for studying the effects of space layouts on BEP used in the 10 articles are analysed and compared in this section, in terms of design variables, energy indicators and BEP calculation methods.

2.3.3.1 Design Variables

The following design variables of space layouts were used in these articles: function allocation and interior partition. Nevertheless, in most studies, they were mixed with other parameters. It is difficult to identify the isolated effects of space layouts. For instance, occupancy and distribution of workstations, and lighting and ventilation requirements were also changed in [42,63]. Other parameters were also changed, such as WWRs in [33,65,67–69,71], types and sizes of shading systems in [69] and opening states of windows in [63].

2.3.3.2 Energy Indicators

Regarding end uses of energy, most of these articles only simulated the energy use for space heating and space cooling, and half of the studies also included the energy use for lighting [33,42,65,67,71]. The energy use for ventilation has not been included yet, while one study tested the air volume supplied by natural ventilation [63]. In addition to energy use, some studies also calculated the indicators for thermal and visual comfort. These indicators include predicted mean vote (PMV) in [68], daylight autonomy in [67] and daylight illuminance in [68], which can provide extra information about BEP in addition to energy use. Regarding the system boundary of assessment, most of these articles defined their energy indicators unclearly: three articles described the system efficiency [33,65,71], and we assume that they tested the final energy; the others did not show system information; thus, we assume that they tested energy demands. Regarding the calculation period, most studies calculated the energy use for the whole year [33,64,65,68,70,71], and some studies only calculated it for peak days [42,63] or season representative days [67].

2.3.3.3 BEP Calculation Methods

Regarding BEP calculation methods, most studies used the dynamic simulation method for higher accuracy, except for two studies [33,71]. Lightscape in [42], Ecotect in [68] and IDA ICE 3.0 in [65] were used for daylighting simulation. TAS in [42], EnergyPlus in [64,67,69] and IDA ICE 3.0 in [65] were used for energy simulation. Although different calculation methods and simulation software were used in different articles, it is impossible to compare the accuracy of the calculation methods and simulation software between articles, as the calculation conditions in different articles are different in terms of materials, climates, WWRs, layouts (floor

areas, interior partitions and functions), etc. Regarding the integration of multi-domains, two studies of [42,63] integrated daylighting and natural ventilation with energy simulation, using Excel to exchange data between the simulation tools of Lightscape and TAS. Another two studies of [33,71] considered the effect of daylighting on the reduction of the artificial lighting demand.

2.4 Effects of Space Layouts on Energy Use

Following the same procedure shown in Section 2.3.2, the other articles were reviewed. Their results were used for the analysis in Section 2.4 and 2.5. As most information has already been shown in Table 2.2, the articles that were analysed in this section and Section 2.5 are introduced briefly. Some articles are not used for the analysis in Section 2.4 and also in Section 2.5: the studies of [33,71] did not show the results of energy performance, and the study of [70] did not present sufficient information for the on BEP calculation. As the articles in Table 2.2 mixed the design variables of space layouts with other parameters, the effects of space layouts cannot be identified directly from the results of these articles. Thus, we selected the cases that were usable to exclude the other design parameters, and reorganised their results to identify the isolated effects of space layouts. The effects on energy use are classified into the effects on space heating and cooling, lighting and ventilation as follows.

2.4.1 Effects on the Energy Use for Space Heating and Cooling

Most articles shown in Table 2.2 assessed the energy use for space heating and cooling. Yi [68] also tested the energy demands for heating and cooling, but in the results, heating and cooling demands were summed up as the annual energy use intensity, which cannot be used for detailed analysis in this study, thus, it was not included in this section. The studies of [42,64,65,67] were analysed and compared below.

2.4.1.1 Analysis of the Relevant Articles

Souza and Alsaadani [64] tested three layouts for an office building in London of the UK, in Cfb, and modelled them with different thermal zoning strategies (Figure 2.4). Detailed information about this article is shown in Table 2.2. Although this study focused on testing the effect of different thermal zoning strategies, the different zoning models actually represent different layouts. Ventilation rates and internal gains were also changed in some simulations, but we only selected the simulations in which only space layouts were changed. The selected results are shown in Table 2.5, and the reduction in the annual heating demand between different zoning strategies is 52%, while the value in the annual cooling demand is 24%.

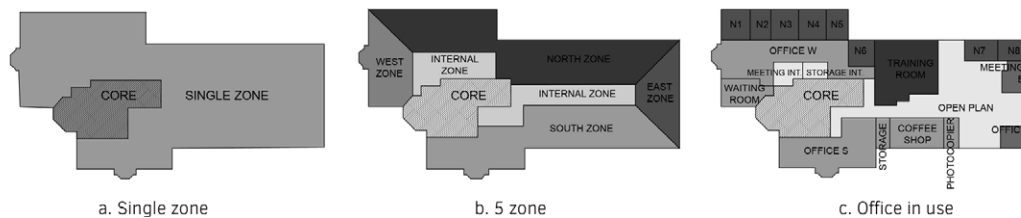

FIG. 2.4 Three layouts modelled with different thermal zoning strategies in [64]. The interior partitions divide the layout into different thermal zones.

TABLE 2.5 Annual energy demand comparison between three layouts, adapted from [64].

	heating demand	cooling demand
'Single zone' layout	8.47 (kWh/m ²)	28.04 (kWh/m ²)
'5-zone' layout	5.59 (kWh/m ²)	37.06 (kWh/m ²)
'Office in use' layout	11.69 (kWh/m ²)	29.72 (kWh/m ²)
reduction (%)	52%	24%

Poirazis et al. [65] compared cell and open office layouts in Gothenburg of Sweden, in the humid continental climate (Dfb) as shown in Figure 2.5, and tested their final energy for space heating, space cooling and lighting. Detailed information about this article is shown in Table 2.2. In total, 102 simulations were run, and plenty of parameters were changed. We selected the layouts with same WWRs, although they still have different occupancy, lighting power densities, illuminance requirements, equipment power densities and heating, ventilation and air-conditioning systems. Although the occupancy is different between the cell and open layouts, this case represents the real situation in practice. The final energy reductions between open and cell layouts are shown in Table 2.6. The reduction in the final energy for heating

between the cell and open layouts is 14%, and the value for cooling is 57%. As shown in Table 2.6, with the increase of WWRs, the effects of space layouts on the final energy for heating, cooling and lighting decrease, which means that space layouts matter less when there are large windows.

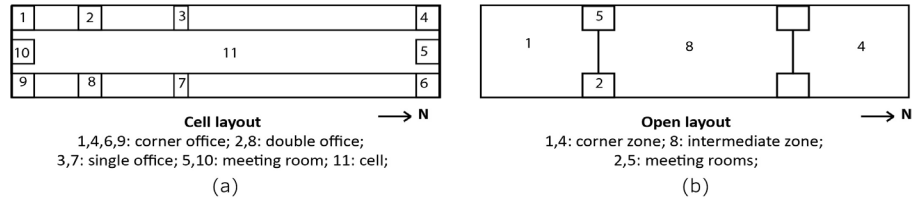

FIG. 2.5 Cell and open layouts in [65]. The interior partitions divide the layout into different thermal zones.

TABLE 2.6 Annual final energy comparison between cell and open layouts, adapted from [65].

	reduction in final energy for heating (cell>open)	reduction in final energy for cooling (cell<open)	reduction in final energy for lighting (cell<open)
30% WWR	14%	57%	4 kWh/m ²
60% WWR	11%	28%	4.1 kWh/m ²
100% WWR	11%	20%	2.7 kWh/m ²

Note: only the reductions and differences in kWh/m² were shown in the original paper.

Dino and Ucoluk [67] simulated the energy demand of a library building in Ankara of Turkey, in a cold semi-arid climate (BSk), with changed space layouts as well as building geometry. Detailed information about this article is shown in Table 2.2. Each layout has several functions, including reading, book storage, administration, café, working and conference, which vary in occupancy densities and equipment gains, heating and cooling set-points and illuminance set-points. The tested indicators relevant to energy use include heating, cooling and lighting demands. They were tested for 4 days, representing four seasons. As this study changed WWRs in addition to space layouts, we cannot identify the isolated effects of space layouts. Only the results of several layouts were shown in the original paper. We selected four layouts with the same geometry for comparison (Figure 2.6), which have a similar amount of total energy demand. The resulting energy indicators of the selected layouts are shown and compared in Table 2.7. According the table, with the change of space layouts and WWRs, the reductions are 19% for heating demand per day and 20% for cooling demand per day. Although with different WWRs, the total energy demands of different layouts are similar (around 3500 kWh/day). This implies that space layouts affect energy demands, although the isolated effects cannot be identified.

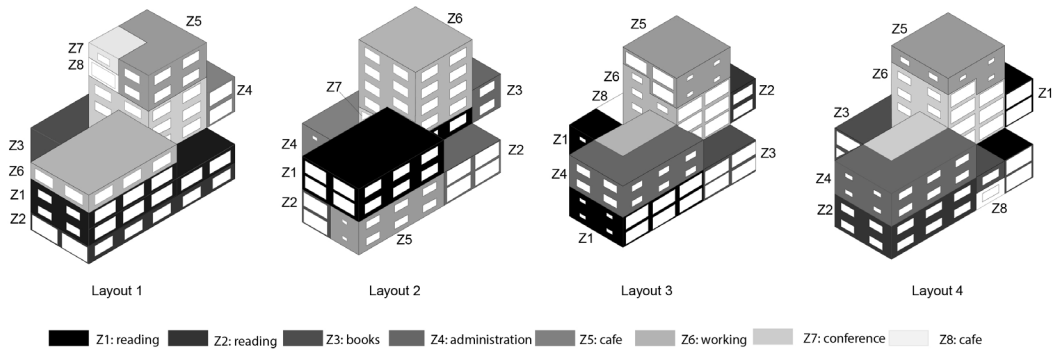

FIG. 2.6 Four different layouts with the same geometry in [67]. Different colours represent different thermal zones.

TABLE 2.7 Energy demand comparison between the selected four layouts, adapted from [67].

layout	Heating demand (kWh/day)	Cooling demand (kWh/day)	Lighting demand (kWh/day)	Illuminance set-point satisfaction
layout 1	1013	1154	1343	2285
layout 2	1092	978	1429	1949
layout 3	1249	924	1334	2378
layout 4	1159	1029	1286	2680
reduction (%)	19%	20%	10%	27%

2.4.1.2 Resulted Effects and Comparison

In addition to the results obtained from Section 2.4.1.1, the results obtained from the analysis of the example article shown in Section 2.3.2 are also used for the analysis in this section. The isolated effects of space layouts can be identified from these articles, except for [67]. By changing space layouts, the resulting reductions in the annual heating and cooling demands are up to 52% and 24%, respectively, for the case of an office building in the UK [64]. The resulting reductions in the heating and cooling demands in peak days are up to 57% and 11%, respectively, for the case of an office building in the UK [42]. The resulting reductions in the annual final energy for heating and cooling are up to 14% and 57%, respectively, for the case of an office building in Sweden [65]. The influence of occupancy on the effect of space layouts on BEP can be identified from [42] as well as the influence of WWRs [65], which show that with the increase of occupancy and WWRs, the reductions between layouts in heating and cooling demands decrease apparently.

Regarding the assessment boundary, both energy demand [42,64] and final energy [65] were tested. Regarding the assessment period, one year [64,65], peak days in winter and summer [42] and four representative days of each season regarding solar irradiation and outside temperature [67] were tested. Regarding the BEP calculation method, the thermal zone division would highly affect the accuracy of the results, as shown in [64]. A simulation model with the detailed thermal zone division as shown in Figure 2.4.c is needed for future studies. In total, three climates (Cfb, Dfb, BSk) were tested and the isolated effects of space layouts were only identified for Cfb and Dfb. However, their results cannot be compared as different layouts are used for the two climates, as well as different energy indicators: heating and cooling demand in peak day [42] and annual heating and cooling demand [64] for Cfb, and annual final energy for heating and cooling for Dfb [65]. Although the studies of [42] and [64] tested the same climates, the layouts used in the two articles are different in floor areas, interior partitions and functions, thus, their results also cannot be compared.

2.4.2 Effects on the Energy Use for Lighting

Three of the articles in Table 2.2, which are also analysed in Section 2.4.1, studied the effects of space layouts on the energy use for lighting [42,65,67]. The resulted effects on the energy use for lighting in the three articles are shown Table 2.4, 2.6 and 2.7, respectively. As shown in Table 2.4, in the study of [42], the biggest reduction in the lighting demand of peak summer is 67%, although the value of the lighting demand is relatively small. The reduction in the lighting demand of peak winter is 43%. Moreover, with the increase of occupancy, the reductions between layouts in the lighting demands of both peak winter and peak summer decrease apparently. The lighting demands of different layouts are almost the same when the layouts are highly occupied with 12 occupants. In the study of [65], the reduction in the final energy for lighting cannot be identified from the original article as only the demand difference in kWh/m² is given. However, as shown in Table 2.6, the effect of space layouts on the lighting demand decreases with the increase of WWRs. From the study of [67], the isolated effect of space layouts on the lighting demand cannot be identified, as WWRs were also changed. Regarding the tested climates, three climates (Cfb, Dfb, BSk) were tested and the isolated effects of space layouts were only identified for Cfb and Dfb. However, their results cannot be compared, as different layouts were used for the two climates, as well as different energy indicators: lighting demand in peak days for Cfb [42] and annual final energy for lighting for Dfb [65]. Compared to the energy use for space heating and cooling, the articles on the energy use for lighting are much less.

2.4.3 Effects on the Energy Use for Ventilation

There is only one article that tested the ventilation performance among the articles shown in Table 2.2. In their another study, Musau and Steemers [63] tested the effect of space layouts on the ventilation performance for office buildings in Garston of the UK, in Cfb. The basic settings were the same as in [42]. Detailed information about this article is shown in Table 2.2. One indicator relevant to ventilation was calculated, i.e., fresh air volume (m^3) supplied by natural ventilation through background vents, which was tested for the peak winter and summer. The results of the original paper were reorganised to identify the effect of space layouts in Table 2.8. According to this table, the biggest reduction between layouts in the air volume supplied by vents of peak winter is 65%. By comparing the variants with a different occupancy in Table 2.8, the following conclusion can also be drawn: the higher the occupancy is, the lower the effect of space layouts on the air volume supplied by natural ventilation in peak winter. Only one climate was tested, i.e., Cfb, and the isolated effect of space layouts was identified for this climate. More studies are needed for this topic specifically for the energy use for ventilation.

TABLE 2.8 Comparison of the fresh air volume supplied by natural ventilation, adapted from [63].

Air volume supplied by vents of peak winter with closed window (m^3)				
	8 occupants	6 occupants	4 occupants	2 occupants
Cell	310	250	170	80
Comb	320	250	170	80
Club	580	490	380	200
Den	620	620	460	230
Hive	620	620	460	230
Reduction (%)	50%	60%	63%	65%
Biggest reduction (%)	65%			

2.5 Effects of Space Layouts on Occupant Comfort

In addition to energy use, the articles in Table 2.2 also tested the indicators for occupant comfort. Among the articles shown in Table 2.2, only thermal and visual comfort was tested, and the articles relevant to occupant comfort were analysed in detail and compared below.

2.5.1 Effects on Thermal Comfort

There are two articles that test the effects of space layouts on thermal comfort [68,69], and they were analysed in detail and compared below.

2.5.1.1 Analysis of the Articles Relevant to Thermal Comfort

Yi [68] simulated an office building in Seoul of South Korea, in the humid continental climate (Dwa), with changed space layouts as well as WWRs. Detailed information about this article is shown in Table 2.2. We only selected three layouts for comparison (Figure 2.7), as their WWRs varied from 31.4% to 35%, which is a small variation. The tested indicators relevant to thermal comfort is PMV. The results are reorganised in Table 2.9, which shows that the reduction in PMV is 13%. The reduction is mainly caused by changing space layouts, as the WWRs have a much smaller variation.

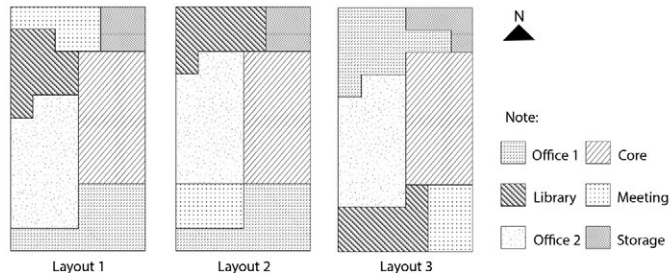

FIG. 2.7 Three layouts with similar WWRs in [68]. The interior partitions divide the layout into different thermal zones.

TABLE 2.9 Energy performance comparison between the selected layouts, adapted from [68].

	PMV	Indoor daylight level (lux)	Shading level
Layout 1	-1.60	309.30	90.80
Layout 2	-1.79	348.50	89.20
Layout 3	-1.55	335.70	89.26
Reduction (%)	13%	11%	2%

Rodrigues et al. [69] simulated a residential building in Coimbra of Portugal, in a temperate Mediterranean climate (Csb), with changed space layouts, WWRs, window orientations, shading systems and floor areas. Detailed information about this article is shown in Table 2.2. The tested indicator is thermal discomfort penalty ($^{\circ}\text{C}$), which was calculated by multiplying a weight factor with the difference between the calculated hourly interior air temperature and the temperature limit for thermal comfort. Two layout sets were compared: one has one floor and the other one has two floors (Figure 2.8). The results of the two sets of layouts are shown and compared in Table 2.10. The biggest reduction in the thermal discomfort is 33% between one-floor layouts and 29% between two-floor layouts. The isolated effect of space layouts on thermal comfort cannot be identified from this study, while it shows the effect of space layouts combined with other parameters, i.e., WWRs, window orientations, shading systems and floor areas.

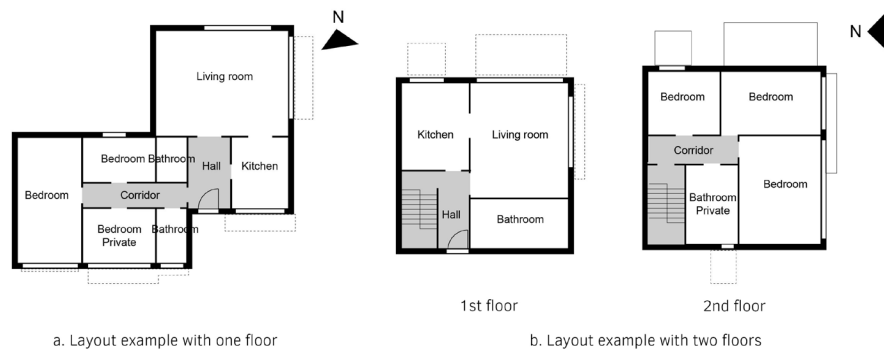

FIG. 2.8 Examples of two layout sets in [69] (left: layout with one floor, right: layout with two floors). The interior partitions divide the layout into different thermal zones.

TABLE 2.10 Hourly thermal discomfort comparison between layouts, adapted from [69] (TDP: thermal discomfort penalty. The higher the thermal penalty, the worse the thermal performance).

layouts with one floor												
layout	-1	-2	-3	-4	-5	-6	-7	-8	-9	-10	-11	-12
TDP of layouts with one floor	20.5°C	23.0°C	23.3°C	25.3°C	25.7°C	25.8°C	26.4°C	26.6°C	27.4°C	27.9°C	29.6°C	30.5°C
reduction	33%											
layouts with two floors												
layout	-13	-14	-15	-16	-17	-18	-19	-20	-21	-22	-23	-24
TDP of layouts with one floor	21.5°C	22.8°C	22.8°C	23.0°C	23.6°C	25.2°C	25.2°C	25.7°C	25.8°C	28.6°C	28.9°C	30.2°C
reduction	29%											

2.5.1.2 Resulted Effects and Comparison

The isolated effects of space layouts cannot be identified in the two studies [68,69], as both studies also changed other parameters, i.e., WWRs in [68], and WWRs, window orientations, shading systems and floor areas in [69]. However, as the variation of WWRs in [68] was small, the reduction in thermal discomfort is mainly caused by changing space layouts. Thus, the reduction in PMV is around 13% by changing the space layouts in South Korea [68]. Two climates were tested (Dwa and Csb), but the isolated effects of space layouts were only identified for Dwa.

2.5.2 Effects on Visual Comfort

There were two studies that tested the effect of space layouts on visual comfort [67,68]. In the study of Yi [68], the indoor daylight level (illuminance) and shading level (the ratio of shaded floor area at 12 pm, 21th Dec) were tested, in addition to PMV. The resulting reduction was 11% in indoor daylight level and 2% in shading level, as shown in Table 2.9. The study of Dino and Ucoluk [67], in addition to energy use, tested the illuminance set-point satisfaction, which refers to how close the calculated daylight illuminance is to the user-defined illuminance set-point. The resulting reduction in the illuminance set-point satisfaction is 27%, as shown in Table 2.7. In both studies, WWRs were also changed in addition to space layouts. However, the variation of WWRs in [68] was small; thus, the reduction is mainly caused by changing space layouts. Two climates were tested (Dwa and BSk), but the isolated effects of space layouts were only identified for Dwa.

2.6 Conclusions and Recommendations

In this paper, the articles relevant to the effects of space layouts on building energy performance (BEP) were reviewed. A methodology for studying the effects of space layouts on BEP is proposed in Section 2.3.1, regarding design variables, energy indicators and BEP calculation methods. Among the large number of studies on building energy-efficient design, only 10 articles were found relevant to the specific topic and they were reviewed in detail to identify the isolated effects of space layouts. The review results show that by only changing space layouts, the energy use for space heating, space cooling and lighting can be reduced significantly.

The resulting effects can be categorised into the isolated effects of space layouts on BEP, and the influence of other design parameters on the effects of space layouts on BEP. Moreover, the recommendations were added regarding future research direction, as well as the methodology for studying the effects of space layouts.

2.6.1 Isolated Effects of Space Layouts on BEP

The isolated effects of space layouts on BEP tested in the 10 articles were classified into the effects on energy use and the effects on occupant comfort. The effects of space layouts on the energy use for space heating and cooling, lighting and ventilation are as follows:

- **Energy use for space heating and cooling:** The isolated effects were identified, and both energy demand and final energy for one year were tested. The resulting reductions in the annual heating and cooling demands were substantial, and the reductions were up to 52% and 24%, respectively, for the case of an office building in the UK with varied thermal zoning. The resulting reductions in the heating and cooling demands in peak days were up to 57% and 11%, respectively, for the case of an office building in the UK. The resulting reductions in the annual final energy for heating and cooling are up to 14% and 57%, respectively, for the case of an office building in Sweden.
- **Energy use for lighting:** Only the isolated effects on the lighting demand for peak summer and winter were tested, and the resulting reductions were significant. The reductions were up to 67% and 43%, respectively, for the case of an office building in the UK.

- **Energy use for ventilation:** Only the air volume supplied by natural ventilation was tested for the peak winter; the resulting reduction was significant, namely, up to 65% for the case of an office building in the UK.

The effects of space layouts on the thermal and visual comfort were as follows:

- **Thermal comfort:** PMV and the thermal discomfort (difference between air temperature and thermal comfort temperature) were tested. Although the isolated effects cannot be identified, the approximate effect on PMV can be identified, and the resulting reduction was smaller than the ones in energy use; around 13% for the case of an office building in South Korea.
- **Visual comfort:** Similar to the thermal comfort, only the approximate effect on the illuminance and shading level can be identified, and the resulting reductions are smaller than the ones in energy use; are around 11% and 2%, respectively, for the case of an office building in South Korea.

2.6.2 The Influence of Other Parameters

From the results of the 10 articles, the influence of other design parameters, i.e., occupancy and WWRs, on the effects of space layouts on BEP can also be identified, as follows:

- **Influence of occupancy:** With the increase of occupancy, the effects of space layouts on the heating demand, cooling demand, lighting demand and air volume from natural ventilation decrease.
- **Influence of WWRs:** With the increase of WWRs, the effects of space layouts on the heating demand, cooling demand and lighting demand decrease.

Regarding climates, in total, five climates were tested for the effects of space layouts on BEP. Two climates were tested for the isolated effects on the energy use for space heating and cooling, and two climates were tested for the isolated effects on the energy use for lighting. However, the results for space heating, cooling and lighting cannot be compared between the climates, as different energy indicators and layouts were used for these climates. Moreover, only one climate was tested for the isolated effects on the energy use for ventilation, thermal comfort and visual comfort, respectively. In addition, the construction site and the surrounding buildings were not considered in the 10 articles analysed in this paper, and these would highly influence the effect of space layouts on BEP.

2.6.3 Recommendations

Designers and architects should consider BEP while designing space layouts, as the effects of space layouts on BEP are significant, although the effects have not been fully confirmed. Studies are needed to compare the effects of space layouts between different climates regarding different energy indicators, in order to obtain the influence of climates on the effects of space layouts on BEP. In order to compare the results between different climates, the same layout should be used in each climate with the same conditions, such as interior partitions, dimensions, forms, orientations and functions, while the functional requirements (such as heating and cooling set-points) and envelope design (transmittance, window area) should adapt to the local standards in order to be suitable for practice and the local climate. Moreover, it would be interesting to test the effects of space layouts on BEP considering the influence of the context with surrounding buildings.

More studies are needed to fully explore the effects of space layouts on BEP. The recommendations for future studies regarding the methodology for studying the effects of space layouts on BEP are as follows.

- **Design variables:** A systematic study on the effects of space layouts on BEP should first only change the design variables of space layouts, while keeping other design parameters constant, in order to identify the isolated effects of space layouts. Then, by adding other design parameters one by one, their influence on the effects of space layouts can be obtained.
- **Energy indicators:** Regarding energy use, more studies are needed, especially on the energy use for lighting and ventilation for a long assessment period, such as one year. Regarding occupant comfort, more indicators for thermal and visual comfort need to be tested.
- **BEP calculation methods:** Regarding the BEP calculation method, a calculation tool with high accuracy is needed. The integration of multi-domain simulations is necessary to predict the real situation and better represent the effects of space layouts, such as integrating daylighting simulation and natural ventilation simulation with energy simulation. In addition, a detailed thermal zone division regarding the different requirements of spaces is necessary as shown in Figure 2.4.c, as it highly affects the results.

References

- [1] Pacheco, R.; Ordóñez, J.; Martínez, G. Energy efficient design of building: A review. *Renew. Sustain. Energy Rev.* **2012**, *16*, 3559–3573, doi:10.1016/j.rser.2012.03.045.
- [2] The American Institute of Architects Design to Construction|AIA ETN. Available online: <https://www.aiaetn.org/find-an-architect/design-to-construction/> (accessed on 7 January 2020).
- [3] Lobos, D.; Donath, D. The problem of space layout in architecture: A survey and reflections. *Arquitetura Rev.* **2010**, *6*, 136–161, doi:10.4013/arq.2010.62.05.
- [4] Bektas Ekici, B.; Aksoy, U.T. Prediction of building energy needs in early stage of design by using ANFIS. *Expert Syst. Appl.* **2011**, *38*, 5352–5358, doi:10.1016/j.eswa.2010.10.021.
- [5] Aksoy, U.T.; Inalli, M. Impacts of some building passive design parameters on heating demand for a cold region. *Build. Environ.* **2006**, *41*, 1742–1754, doi:10.1016/j.buildenv.2005.07.011.
- [6] Florides, G.A.; Tassou, S.A.; Kalogirou, S.A.; Wrobel, L.C. Measures used to lower building energy consumption and their cost effectiveness. *Appl. Energy* **2002**, *73*, 299–328, doi:10.1016/S0360-2619(02)00119-8.
- [7] Hemsath, T.L.; Alagheband Bandhosseini, K. Sensitivity analysis evaluating basic building geometry's effect on energy use. *Renew. Energy* **2015**, *76*, 526–538, doi:10.1016/j.renene.2014.11.044.
- [8] Tibermacine, I.; Zemmouri, N. Effects of building topology on energy consumption in hot and arid regions. *Energy Procedia* **2017**, *139*, 664–669, doi:10.1016/j.egypro.2017.11.269.
- [9] Raji, B.; Tenpierik, M.; van den Dobbelen, A. Early-Stage Design Considerations for the Energy-Efficiency of High-Rise Office Buildings. *Sustainability* **2017**, *9*, 623, doi:10.3390/su9040623.
- [10] Xia, B. Low Carbon Design Research on the Space Layout Types of Office Buildings. In Proceedings of the IOP Conference Series: Earth and Environmental Science, Chongqing, China, 25–26 November 2017; Volume 108, p. 42054, doi:10.1088/1755-1315/108/4/042054.
- [11] Depecker, P.; Menezo, C.; Virgone, J.; Lepers, S. Design of buildings shape and energetic consumption. *Build. Environ.* **2001**, *36*, 627–635, doi:10.1016/S0360-1323(00)00044-5.
- [12] Rashdi, W.S.S.W.M.; Embi, M.R. Analysing Optimum Building form in Relation to Lower Cooling Load. *Procedia Soc. Behav. Sci.* **2016**, *222*, 782–790, doi:10.1016/j.sbspro.2016.05.161.
- [13] Anand, P.; Deb, C.; Alur, R. A simplified tool for building layout design based on thermal comfort simulations. *Front. Archit. Res.* **2017**, *6*, 218–230, doi:10.1016/j.foar.2017.03.001.
- [14] van den Dobbelen, A.; Thijssen, S.; Colaleo, V.; Metz, T. Ecology of the Building Geometry-Environmental performance of different building shapes. In Proceedings of the CIB World Building Congress, Cape Town, South Africa, 14–17 May 2007; pp. 178–188.
- [15] Aste, N.; Angelotti, A.; Buzzetti, M. The influence of the external walls thermal inertia on the energy performance of well insulated buildings. *Energy Build.* **2009**, *41*, 1181–1187, doi:10.1016/j.enbuild.2009.06.005.
- [16] Yang, L.; Lam, J.C.; Tsang, C.L. Energy performance of building envelopes in different climate zones in China. *Appl. Energy* **2008**, *85*, 800–817, doi:10.1016/j.apenergy.2007.11.002.
- [17] Halawa, E.; Ghaffarianhoseini, A.; Ghaffarianhoseini, A.; Trombley, J.; Hassan, N.; Baig, M.; Yusoff, S.Y.; Azzam Ismail, M. A review on energy conscious designs of building façades in hot and humid climates: Lessons for (and from) Kuala Lumpur and Darwin. *Renew. Sustain. Energy Rev.* **2018**, *82*, 2147–2161, doi:10.1016/j.rser.2017.08.061.
- [18] Pérez-Lombard, L.; Ortiz, J.; Pout, C. A review on buildings energy consumption information. *Energy Build.* **2008**, *40*, 394–398, doi:10.1016/j.enbuild.2007.03.007.
- [19] Latha, P.K.; Darshana, Y.; Venugopal, V. Role of building material in thermal comfort in tropical climates -A review. *J. Build. Eng.* **2015**, *3*, 104–113, doi:10.1016/j.jobee.2015.06.003.
- [20] Nematshoua, M.K.; Orosa, J.A. Building construction materials effect in tropical wet and cold climates: A case study of office buildings in Cameroon. *Case Stud. Therm. Eng.* **2016**, *7*, 55–65, doi:10.1016/j.csite.2016.01.007.
- [21] Aldawoud, A. The influence of the atrium geometry on the building energy performance. *Energy Build.* **2013**, *57*, 1–5, doi:10.1016/j.enbuild.2012.10.038.
- [22] Taleghani, M.; Tenpierik, M.; van den Dobbelen, A. Energy performance and thermal comfort of courtyard/atrium dwellings in the Netherlands in the light of climate change. *Renew. Energy* **2014**, *63*, 486–497, doi:10.1016/j.renene.2013.09.028.

- [23] Tzempelikos, A.; Athienitis, A.K. The impact of shading design and control on building cooling and lighting demand. *Sol. Energy* **2007**, *81*, 369–382, doi:10.1016/j.solener.2006.06.015.
- [24] Nielsen, M.V.; Svendsen, S.; Jensen, L.B. Quantifying the potential of automated dynamic solar shading in office buildings through integrated simulations of energy and daylight. *Sol. Energy* **2011**, *85*, 757–768, doi:10.1016/j.solener.2011.01.010.
- [25] Levin, P.H. Use of Graphs to Decide the Optimal Layout of Buildings. *Archit. J.* **1964**, 809–815.
- [26] Krawczyk, R.J.; Dudnik, E.E. Space Plan: A user oriented package for the evaluation and the generation of spatial inter-relationships. In Proceedings of the 10th Design Automation Workshop, Portland, OR, USA, 25–27 June 1973; pp. 121–138.
- [27] Ahmadi, A.; Jokar, M.R.A. An efficient multiple-stage mathematical programming method for advanced single and multi-floor facility layout problems. *Appl. Math. Model.* **2016**, *40*, 5605–5620, doi:10.1016/j.apm.2016.01.014.
- [28] Verma, M.; Thakur, M.K. Architectural space planning using Genetic Algorithms. In Proceedings of the 2nd International Conference on Computer and Automation Engineering (ICCAE), Singapore, 26–28 February 2010; pp. 268–275, doi:10.1109/ICCAE.2010.5451497.
- [29] Arvin, S.A.; House, D.H. Modeling architectural design objectives in physically based space planning. *Autom. Constr.* **2002**, *11*, 213–225, doi:10.1016/S0926-5805(00)00099-6.
- [30] Guo, Z.; Li, B. Evolutionary approach for spatial architecture layout design enhanced by an agent-based topology finding system. *Front. Archit. Res.* **2017**, *6*, 53–62, doi:10.1016/j.foar.2016.11.003.
- [31] Keatruangkamala, K.; Sinapiromsaran, K. Optimizing Architectural Layout Design via Mixed Integer Programming. *Comput. Aided Archit. Des. Futures* **2005**, 175–184, doi:10.1007/1-4020-3698-1_16.
- [32] Medjdoub, B.; Yannou, B. Separating topology and geometry in space planning. *Comput. Des.* **2000**, *32*, 39–61, doi:10.1016/S0010-4485(99)00084-6.
- [33] Michalek, J.; Choudary, R.; Papalambros, P. Architectural layout design optimization. *Eng. Optim.* **2002**, *34*, 37–41, doi:10.1080/03052150214016.
- [34] Chatzikonstantinou, I. A 3-Dimensional Architectural Layout Generation Procedure for Optimization Applications: DC-RVD. In Proceedings of the 2014 ECAADe Conference, Northumbria, UK, 10–12 September 2014; pp. 287–296.
- [35] Veitch, J.A. Workplace design contributions to mental health and well-being. *Healthc. Pap.* **2011**, *11*, 38–46, doi:10.12927/hcpap.2011.22409.
- [36] Zerella, S.; von Treuer, K.; Albrecht, S.L. The influence of office layout features on employee perception of organizational culture. *J. Environ. Psychol.* **2017**, *54*, 1–10, doi:10.1016/j.jenvp.2017.08.004.
- [37] Nagy, D.; Lau, D.; Locke, J.; Stoddart, J.; Villaggi, L.; Wang, R.; Zhao, D.; Benjamin, D. Project Discover: An application of generative design for architectural space planning. In Proceedings of the Symposium on Simulation for Architecture and Urban Design, Toronto, ON, Canada, 22–24 May 2017; pp. 59–66, doi:10.5555/3289787.3289794.
- [38] Das, S.; Day, C.; Hauck, A.; Haymaker, J.; Davis, D. Space Plan Generator: Rapid Generation & Evaluation of Floor Plan Design Options to Inform Decision Making. In Proceedings of the ACADIA, Ann Arbor, MI, USA, 27–29 October 2016; pp. 106–115.
- [39] Lobos, D.; Trebilcock, M. Building performance information and graphs approach for the design of floor plans. *Arquiteturarevista* **2014**, *10*, 23–30, doi:10.4013/arq.2014.101.03.
- [40] Haapakangas, A.; Hongisto, V.; Varjo, J.; Lahtinen, M. Benefits of quiet workspaces in open-plan offices – Evidence from two office relocations. *J. Environ. Psychol.* **2018**, *56*, 63–75, doi:10.1016/j.jenvp.2018.03.003.
- [41] Hedge, A. The Open-Plan Office: A Systematic Investigation of Employee Reactions to Their Work Environment. *Environ. Behav.* **1982**, *14*, 519–542.
- [42] Musau, F.; Steemers, K. Space Planning and Energy Efficiency in Office Buildings: The Role of Spatial and Temporal Diversity. *Archit. Sci. Rev.* **2008**, *51*, 133–145, doi:10.3763/asre.2008.5117.
- [43] Goldstein, R.; Tessier, A.; Khan, A.; East, K.S. Space Layout in Occupant Behavior Simulation. In Proceedings of IBPSA-AIRAH Building Simulation Conference, Sydney, Australia, 14–16 November 2011; pp. 1073–1080.
- [44] Netherlands Standardization Institute. Energy Performance of Buildings –Part 1: Indoor Environmental Input Parameters for Design and Assessment of Energy Performance of Buildings Addressing Indoor Air Quality, Thermal Environment, Lighting and Acoustics -Module M1–6; NEN-16798-1; Netherlands Standardization Institute: Delft, the Netherlands, 2015; pp. 42–43.

- [45] Society of Light and Lighting Detailed room design information. In *Lighting Guide 7 -Office Lighting*; CIBSE: London, UK, 2005; pp. 45–59.
- [46] Sharples, S.; Lash, D. Daylight in atrium buildings: A critical review. *Archit. Sci. Rev.* **2007**, *50*, 301–312, doi:10.3763/asre.2007.5037.
- [47] Du, J.; Sharples, S. The variation of daylight levels across atrium walls: Reflectance distribution and well geometry effects under overcast sky conditions. *Sol. Energy* **2011**, *85*, 2085–2100, doi:10.1016/j.solener.2011.05.015.
- [48] Huang, Y.; Borong, L.; Yao, N.; Yingxin, Z. Functional Relationship between Lighting Energy Consumption and the Main Parameters for Double Atrium Offices. *Procedia Eng.* **2015**, *121*, 1869–1879, doi:10.1016/j.proeng.2015.09.169.
- [49] Freewan, A.A. Modifying Courtyard Wall Geometries to Optimize the Daylight Performance of the Courtyard. *Sustain. Energy Build.* **2011**, *7*, 57–64, doi:10.1007/978-3-642-17387-5_6.
- [50] Seo, D.; Park, L.; Ihm, P.; Krarti, M. Optimal electrical circuiting layout and desk location for daylighting controlled spaces. *Energy Build.* **2012**, *51*, 122–130, doi:10.1016/j.enbuild.2012.04.020.
- [51] Hassanli, S.; Chauhan, K.; Zhao, M.; Kwok, K.C.S. Application of through-building openings for wind energy harvesting in built environment. *J. Wind Eng. Ind. Aerodyn.* **2019**, *184*, 445–455, doi:10.1016/j.jweia.2018.11.030.
- [52] Xu, X.; Luo, F.; Wang, W.; Hong, T.; Fu, X.; Xu, X.; Luo, F.; Wang, W.; Hong, T.; Fu, X. Performance-Based Evaluation of Courtyard Design in China's Cold-Winter Hot-Summer Climate Regions. *Sustainability* **2018**, *10*, 3950, doi:10.3390/su10113950.
- [53] Asadi, S.; Fakhari, M.; Fayaz, R.; Mahdavi Parsa, A. The effect of solar chimney layout on ventilation rate in buildings. *Energy Build.* **2016**, *123*, 71–78, doi:10.1016/j.enbuild.2016.04.047.
- [54] Moosavi, L.; Mahyuddin, N.; Ab Ghafar, N.; Azzam Ismail, M. Thermal performance of atria: An overview of natural ventilation effective designs. *Renew. Sustain. Energy Rev.* **2014**, *34*, 654–670, doi:10.1016/j.rser.2014.02.035.
- [55] Lomas, K.J. Architectural design of an advanced naturally ventilated building form. *Energy Build.* **2007**, *39*, 166–181, doi:10.1016/j.enbuild.2006.05.004.
- [56] Du, X.; Bokel, R.; van den Dobbelsteen, A. The Potential of Using Space Syntax Approach To Predict the Effect of Building Spatial Configuration for Summer Thermal Comfort. In Proceedings of the Plea-Architecture in (R) evolution, Bologna, Italy, 09–11 September 2015.
- [57] Du, X.; Bokel, R.; van den Dobbelsteen, A. Architectural Spatial Design Strategies for Summer Microclimate Control in Buildings: A Comparative Case Study of Chinese Vernacular and Modern Houses. *J. Asian Archit. Build. Eng.* **2016**, *15*, 327–334, doi:10.3130/jaabe.15.327.
- [58] Shahzad, S.; Brennan, J.; Theodossopoulos, D.; Hughes, B.; Calautit, J.K. Energy and comfort in contemporary open plan and traditional personal offices. *Appl. Energy* **2017**, *185*, 1542–1555, doi:10.1016/j.apenergy.2016.02.100.
- [59] Shahzad, S.; Brennan, J.; Theodossopoulos, D.; Hughes, B.; Calautit, J.K. A study of the impact of individual thermal control on user comfort in the workplace: Norwegian cellular vs. British open plan offices. *Archit. Sci. Rev.* **2017**, *60*, 49–61, doi:10.1080/00038628.2016.1235544.
- [60] Foster, M.; Oreszczyn, T. Occupant control of passive systems: The use of Venetian blinds. *Build. Environ.* **2001**, *36*, 149–155, doi:10.1016/S0360-1323(99)00074-8.
- [61] Haq, M.A.U.; Hassan, M.Y.; Abdullah, H.; Rahman, H.A.; Abdullah, M.P.; Hussin, F.; Said, D.M. A review on lighting control technologies in commercial buildings, their performance and affecting factors. *Renew. Sustain. Energy Rev.* **2014**, *33*, 268–279, doi:10.1016/j.rser.2014.01.090.
- [62] Schulze, T.; Eicker, U. Controlled natural ventilation for energy efficient buildings. *Energy Build.* **2013**, *56*, 221–232, doi:10.1016/j.enbuild.2012.07.044.
- [63] Musau, F.; Steemers, K. Space Planning, Ventilation and Energy Efficiency in Offices. *Int. J. Vent.* **2009**, *8*, 9–22, doi:10.1080/14733315.2006.11683828.
- [64] Souza de, C.B.; Alsaadani, S. Thermal zoning in speculative office buildings: Discussing the connections between space layout and inside temperature control. In Proceedings of the First Building Simulation and Optimization Conference, Loughborough, UK, 10–11 September 2012; pp. 417–424.
- [65] Poirazis, H.; Blomsterberg, Å.; Wall, M. Energy simulations for glazed office buildings in Sweden. *Energy Build.* **2008**, *40*, 1161–1170, doi:10.1016/j.enbuild.2007.10.011.
- [66] EQUA Simulation AB IDA ICE -Simulation Software|EQUA. Available online: <https://www.equa.se/en/ida-ice> (accessed on 29 March 2019).

- [67] Dino, I.G.; Üçoluk, G. Multiobjective Design Optimization of Building Space Layout, Energy, and Daylighting Performance. *J. Comput. Civ. Eng.* **2017**, *31*, 04017025, doi:10.1061/(ASCE)CP.1943-5487.0000669.
- [68] Yi, H. User-driven automation for optimal thermal-zone layout during space programming phases. *Archit. Sci. Rev.* **2016**, *8628*, doi:10.1080/00038628.2015.1021747.
- [69] Rodrigues, E.; Gaspar, A.R.; Gomes, Á. Automated approach for design generation and thermal assessment of alternative floor plans. *Energy Build.* **2014**, *81*, 170–181, doi:10.1016/j.enbuild.2014.06.016.
- [70] Dogan, T.; Reinhart, C.; Michalatos, P. Automated multi-zone building energy model generation for schematic design and urban massing studies. In Proceedings of the IBPSA Esim conference, Ottawa, ON, Canada, 7–10 May 2014.
- [71] Baušys, R.; Pankrašovaite, I. Optimization of architectural layout by the improved genetic algorithm. *Civ. Eng. Manag.* **2005**, *13*, 37–41, doi:10.1080/13923730.2005.9636328.
- [72] Beck, H.E.; Zimmermann, N.E.; McVicar, T.R.; Vergopolan, N.; Berg, A.; Wood, E.F. Present and future köppen-geiger climate classification maps at 1-km resolution. *Sci. Data* **2018**, *5*, doi:10.1038/sdata.2018.214.
- [73] Dino, I.G. An evolutionary approach for 3D architectural space layout design exploration. *Autom. Constr.* **2016**, *69*, 131–150, doi:10.1016/j.autcon.2016.05.020.
- [74] Zawadzki, M.H.; Tateyama, K.; Nishikawa, I. The constraints satisfaction problem approach in the design of an architectural functional layout. *Eng. Optim.* **2011**, *43*, 943–966, doi:10.1080/0305215X.2010.527005.
- [75] Netherlands Standardization Institute. *Energy Performance of Buildings –Overarching Standard EPBD*; NEN-EN 15603; Netherlands Standardization Institute: Delft, the Netherlands, 2013; pp. 28–35.
- [76] Jansen, C.S.; Tenpierik, M. *Defining the Ambition for An EFL ‘Low Energy’ Building*; Delft University of Technology, Delft, The Netherlands, 2015.
- [77] Loonen, R.C.G.M.; Favoino, F.; Hensen, J.L.M.; Overend, M. Review of current status, requirements and opportunities for building performance simulation of adaptive facades. *J. Build. Perform. Simul.* **2017**, *10*, 205–223, doi:10.1080/19401493.2016.1152303.
- [78] Trčka, M.; Hensen, J.L.M.; Wetter, M. Co-simulation of innovative integrated HVAC systems in buildings. *J. Build. Perform. Simul.* **2009**, *2*, 209–230, doi:10.1080/19401490903051959.
- [79] Trčka, M.; Hensen, J.L.M.; Wetter, M. Co-simulation for performance prediction of integrated building and HVAC systems – An analysis of solution characteristics using a two-body system. *Simul. Model. Pract. Theory* **2010**, *18*, 957–970, doi:10.1016/J.SIMPAT.2010.02.011.
- [80] Beausoleil-Morrison, I.; Macdonald, F.; Kummert, M.; Jost, R.; McDowell, T. Co-simulation between ESP-r and TRNSYS: More highly resolved modelling of integrated building and energy systems. In Proceedings of the 13th Conference of International Building Performance Simulation Association, Chambéry, France, 26–28 August 2013; pp. 3458–3465.
- [81] Itard, L. Energy in the Built Environment. In *Sustainable Urban Environments*; Springer, Dordrecht, New York, 2012; pp. 113–175, doi:10.1007/978-94-007-1294-2.
- [82] Welcome|TRNSYS : Transient System Simulation Tool. Available online: <http://www.trnsys.com/> (accessed on 29 January 2019).
- [83] EnergyPlus EnergyPlus. Available online: <https://energyplus.net/> (accessed on 29 January 2019).
- [84] ESP-r. Available online: <http://www.esru.strath.ac.uk/Programs/ESP-r.htm> (accessed on 29 January 2019).
- [85] Woloszyn, M.; Rusaouen, G.; Covalet, D. *Whole Building Simulation Tools: Clim 2000*; Zurich, IEA Annex 41; 2004; pp. 1–15.

3 Effect of Space Layouts on the Energy Performance of Office Buildings in Three Climates

This chapter is adapted from a journal paper published on 28 Jan 2021: T. Du, S. Jansen, M. Turrin, A. van den Dobbelaere, Effect of space layouts on the energy performance of office buildings in three climates, J. Build. Eng. 39 (2021) 102198. <https://doi.org/10.1016/j.jobe.2021.102198>.

ABSTRACT Numerous studies have shown that architectural design affects energy performance significantly. However, the effect of space layouts on building energy performance has not been fully analysed. In this paper, we aim to study the effect of space layouts on energy performance. An office building was used as the reference, and 11 layout variants were proposed and compared for energy performance. Three climates (temperate, cold and tropical) were inspected, with three typical cities (Amsterdam, Harbin and Singapore). Dynamic simulation was conducted for the energy performance assessment integrating daylighting simulation with energy simulation. For each layout, two situations were simulated: one has no shading system, and the other one has an exterior screen for shading. Based on the simulation results, it is found that lighting demand is affected the most by the layout variance, and the resulting maximum difference (difference divided by the highest demand) happens in Harbin, being 46% without shading and 35% with shading. Regarding the sum of the final energy for heating, cooling and lighting, using a heat pump system, the

maximum difference is 8% for the layouts both without and with shading system occurring in Amsterdam.

ABBREVIATIONS BEP: building energy performance. WWR: window-to-wall ratio.

3.1 Introduction

Studies have shown that the architectural design has the highest potential for decreasing the environmental impacts and costs among the whole life-cycle process [1]. Plenty of studies have analysed the impact of geometry factors [2] including orientation, window-to-wall ratio (WWR), and room width-to-depth ratio, envelopes [3], façades, materials [4], and surroundings [5] on the building energy performance (BEP), and their results show that BEP is highly affected. The study of [2] shows that the geometry factors of window orientation, WWR, and room width to depth ratio affect the annual energy consumption in an office building significantly in hot and cold climates, while marginally in temperature climates. The study [3] shows that the properties of envelopes, like thermal mass, airtightness and infiltration, are crucial in influencing building energy consumption. The innovations in solar thermal façade [6], green façade [7], and kinetic façade [8] have been shown to be effective in improving energy performance. The study of [4] shows that the triple-glazing helps to save the cooling consumption by 6.3% compared to a single clear glass. The study of [5] shows that the urban context, considering its influence on casting shadows and reflecting solar radiation, causes a difference from 9% to 12% in the energy consumption between different stories of one building. As an important task of architectural design, space layout design occurs between ‘scheme design’ and ‘design development’ in the early design phase [9]. The architectural space layout includes the interior collocation of different rooms, the interior layout, and the placement of interior wall [10]. The geometry of buildings is also affected by space layout design.

The following brief review attempts to isolate the effect of space layouts and refers to the cases in which the effect is attributed solely by space layouts. The effect is indicated as ‘maximum difference’ (%), which is calculated by dividing the difference between the highest and lowest resulting energy demand by the highest demand. In [11], five space layouts of an office building in the UK were simulated and their energy demand was compared, and the maximum difference by only changing space layouts was 57% in the heating demand for peak winter and 67% in the lighting

demand for peak summer. In [12], the same five space layouts as in [11] were simulated and compared for the air volume provided by natural ventilation in peak winter, and the maximum difference was 65%. In [13], three layouts for an office building in the UK, which were created with different thermal zoning strategies, were simulated and compared, and the maximum difference was 52% in the heating demand for one year and 24% in the cooling demand. In [14], two layouts (cell and open) of an office building in Sweden were simulated and compared, and the maximum difference was 14% in the heating demand and 57% in the cooling demand. In [15], various layouts with the same geometry of a library building in Turkey were simulated and compared, and the maximum difference was 19% in the heating demand per day, 20% in the cooling demand, and 10% for the lighting demand. In [16], several layouts with the same boundary of an office building in South Korea were simulated and compared, and the maximum difference was 8% in the annual energy use, and 15% in Predicted Mean Vote (PMV). In [17], various layouts of a residential building in Portugal were simulated and compared, and the maximum difference in the thermal discomfort was 33% for the buildings with one floor and 29% for the buildings with two floors. According to these studies, it is meaningful to fully investigate the effect of space layouts on BEP.

However, most of the relevant studies not only changed space layouts, but also changed other parameters simultaneously. For instance, in addition to space layouts, the studies of [11,12] also changed space use densities, occupancy, and distributions of workstations; the studies of [14–19] also changed WWR. Mixing space layouts with other design parameters makes it impossible to tell the isolated effect of space layouts on BEP. Regarding energy indicators, thermal (heating and cooling) demand was detected in most of the relevant studies, while lighting and ventilation demand was rarely assessed. Some studies only calculated the energy demand for peak days [11,12] or season representative days [15]. Regarding the calculation method of energy performance, although most studies used dynamic simulation, some studies used the simplified steady-state calculation method like in [18,19]. A systematic study on the effect of space layouts on BEP is needed, in which only space layouts are changed with the other parameters constant, in order to identify the isolated effect of space layouts. In this study an office building was chosen as the reference. The effect of space layouts on the energy demand of heating, cooling and lighting was studied, as well as the effect on the resulting final energy demand.

Although both energy indicators (like energy demands) and comfort indicators (like PMV and indicators relevant to daylighting comfort) are mentioned as indicators in Section 2.3.3.2, only energy demands for lighting, cooling and heating are used as energy indicators in this chapter. The energy demands for heating and cooling are based on set-point temperatures for heating and cooling, which in turn are related

to the thermal comfort given the different functions of the layout. The temperature set-points are deliberately differentiated between functions, since otherwise less changes in energy demand can be expected from different layouts.

3.2 Investigated space layouts and climates

An existing office building is used as the reference, and 11 variants were designed based on the reference space layout. Each layout was simulated in three climates, aiming to measure the different effects of space layouts in different climates.

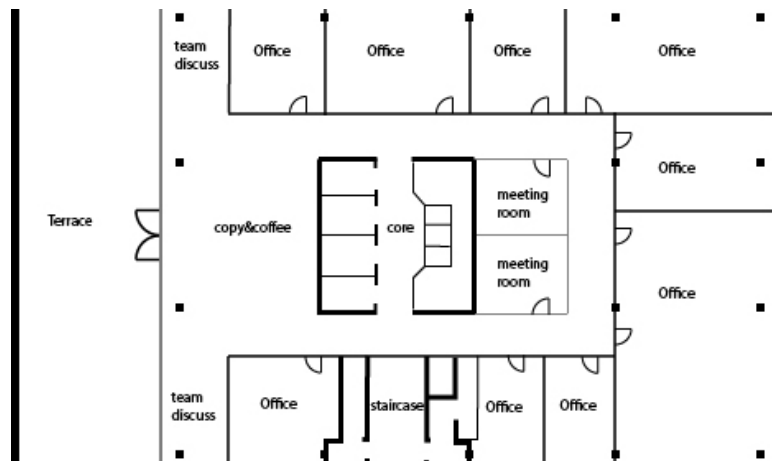

FIG. 3.1 Space layout of the reference building, adapted from [20]

3.2.1 Reference building and investigated space layouts

The space layout of the office building as reference is shown in Figure 3.1 [20], and 11 layout variants were designed (Figure 3.2) based on the reference layout. These variants were developed according to the layout typologies of office buildings proposed by Yeang [21] with different core locations. Each layout has 12 rooms, and each room is 9 m wide, 9 m deep, and 3 m high (floor to ceiling). The proportion of different functions within a layout affects BEP greatly, as different functions have different requirements for BEP. In this paper, we only studied the variants with

the same proportion of different functions: each layout has 6 offices, 2 meeting rooms, 1 canteen, 1 break room, 1 core, and 1 staircase. This proportion is within the threshold of space allocation ratios for office buildings as shown in [22]. The effect of corridors is ignored and not modelled in these layouts in order to relieve the pressure on simulation. We designed the layout variants that would have the highest or lowest energy demand.

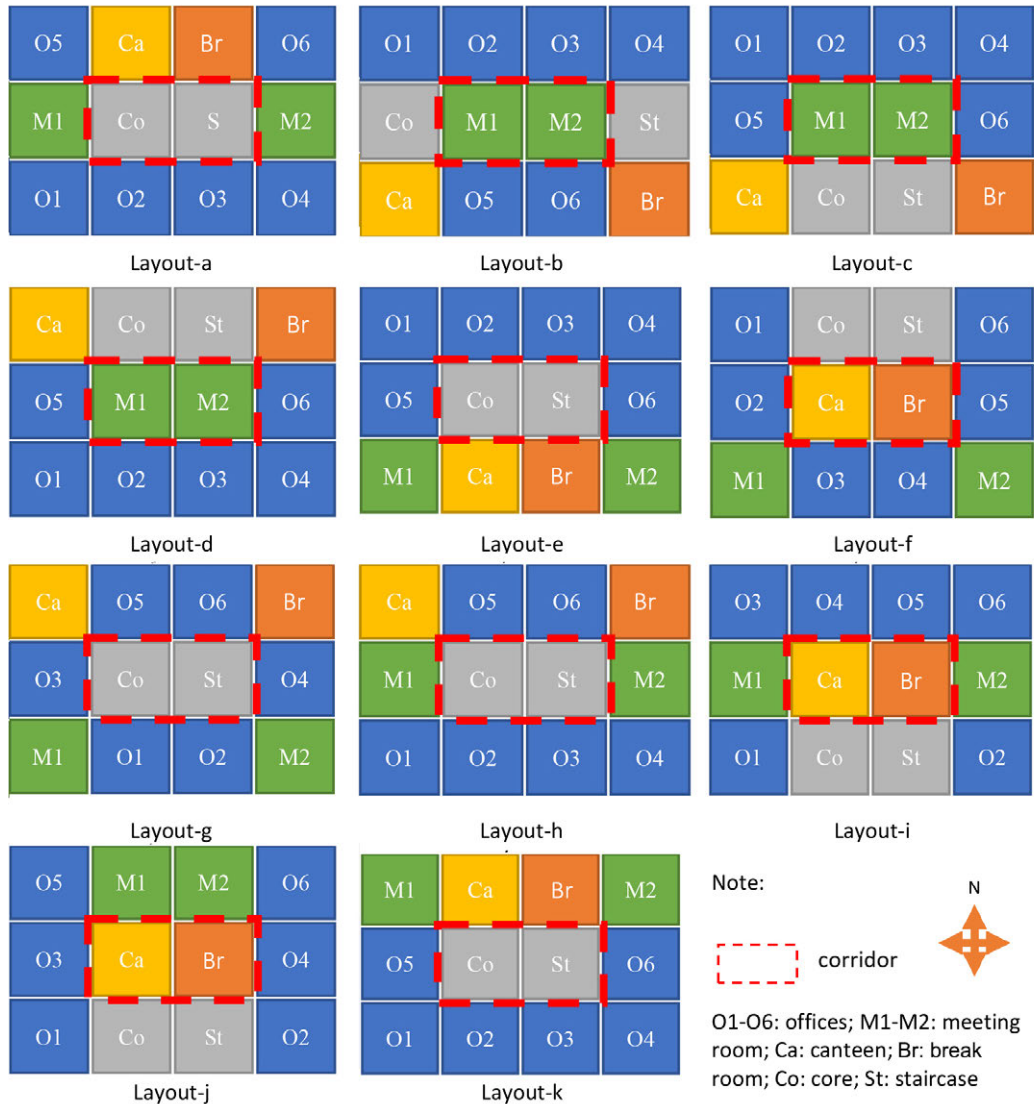

FIG. 3.2 Proposed 11 variants of the reference layout

3.2.2 Investigated climates

Three climates of three typical cities were tested: Amsterdam in the Netherlands for the temperate climate (Appendix 3.a, 3.b, 3.c), Harbin in China for the cold climate (Appendix 3.d, 3.e, 3.f), and Singapore for the tropical climate (Appendix 3.g, 3.h, 3.i). For the calculation of energy demand, we used the method of simulation (see Section 3.3.4). The study of [23] proposed a new method instead of simulation, to estimate the energy demand in different climates, by using normalisation factors based on air temperature degree days. This method would help to save much computational time compared to simulation. However, this method is not suitable for the goal of this paper, as insulation values and windows types were also adapted according to the common use in the different climates in this study. Besides, the cooling demand was only tested for Central and North European climates in [23], which is not suitable for this study, in which the tropical climate is also included. Therefore, the simulation method is used in this study to compare the energy demand in different climates. The weather data is from EnergyPlus [24]. The data source of the international weather for energy calculations (IWECC) [25] was used, as it is available for all the three cities.

3.3 BEP assessment of layouts

The BEP of layouts was assessed with dynamic simulation, coupling daylighting simulation (in Daysim [26], a Radiance [27] based daylighting analysis software) with energy simulation (in EnergyPlus [28]). The reason for coupling Daysim with EnergyPlus is that EnergyPlus has much low accuracy in daylighting simulation. The calculated horizontal illuminances with EnergyPlus has a difference of more than 100% compared to the measured values, as shown in [29]. Radiance has been proven to be accurate in daylighting simulation for the office with external shading, as shown in [30]. Coupling EnergyPlus with Daysim helps to improve the accuracy of calculated energy demand by providing a more accurate lighting schedule calculated based on the daylighting simulation. In addition, a detailed daylighting simulation, like multiple lighting zones and multiple dynamic shading groups for one room, is easier to be implemented in Daysim compared to EnergyPlus.

The simulation tools were operated with the plugins of Ladybug and Honeybee for Grasshopper [31] in this study. The effectiveness of the plugins in daylighting and energy simulation has been proved in [32–34]. The proposed space layouts were simulated for heating, cooling and lighting demand in three climates, and each layout was simulated both with and without a shading system. The detailed method for assessment is shown below.

3.3.1 Procedure for integrating daylighting simulation with energy simulation

A space layout determines the orientation of each room, thereby influencing the amount of daylight penetrating each room. Thus, it influences the lighting demand of the total building. Moreover, the internal gains related to both daylighting and artificial lighting affect the thermal performance of buildings. Hence, only if the influence of daylighting on energy performance is integrated into the simulation process, the calculated results indicate properly the effect of space layouts on BEP. Therefore, daylighting simulation was integrated with energy simulation in the simulation model, and a description of how the simulation tools were integrated is presented below.

For layouts without a shading system, the following procedure was used (Figure 3.3.a): step-1, creating the 3D model for the space layout in Grasshopper with constructions; step-2, creating the model for daylighting simulation in Daysim, with the lighting system control and sensor points for each room; step-3, simulating the hourly illuminance of each sensor point for the whole year; step-4, calculating the schedule of the supplementary artificial lighting, based on the calculated daylighting illuminance and the required illuminance of each room; step-5, creating the model for energy simulation in EnergyPlus with occupancy schedule, equipment loads, and HVAC system, as well as the schedule of supplementary artificial lighting; step-6, simulating the hourly energy demand for heating, cooling and lighting in EnergyPlus; step-7, exporting the resulting energy demand to Excel and analysing the results.

For layouts **with** a shading system, the following steps were added to the procedure described above (Figure 3.3.b). In step-2, adding the shading system (surface, material and control strategy) to the model for daylighting simulation in Daysim; in step-3, calculating the vertical illuminance on windows in different orientations, and calculating the shading schedule based on the vertical illuminance, and running daylighting simulation twice for each layout (**without** shading and **with** shading); in

step 4, calculating the schedule of the supplementary artificial lighting, based on the hourly illuminance both with and without the shading system, as well as the shading schedule obtained from step-3; in step-5, adding the shading system to the model for energy simulation in EnergyPlus, as well as the shading schedule obtained from step-3.

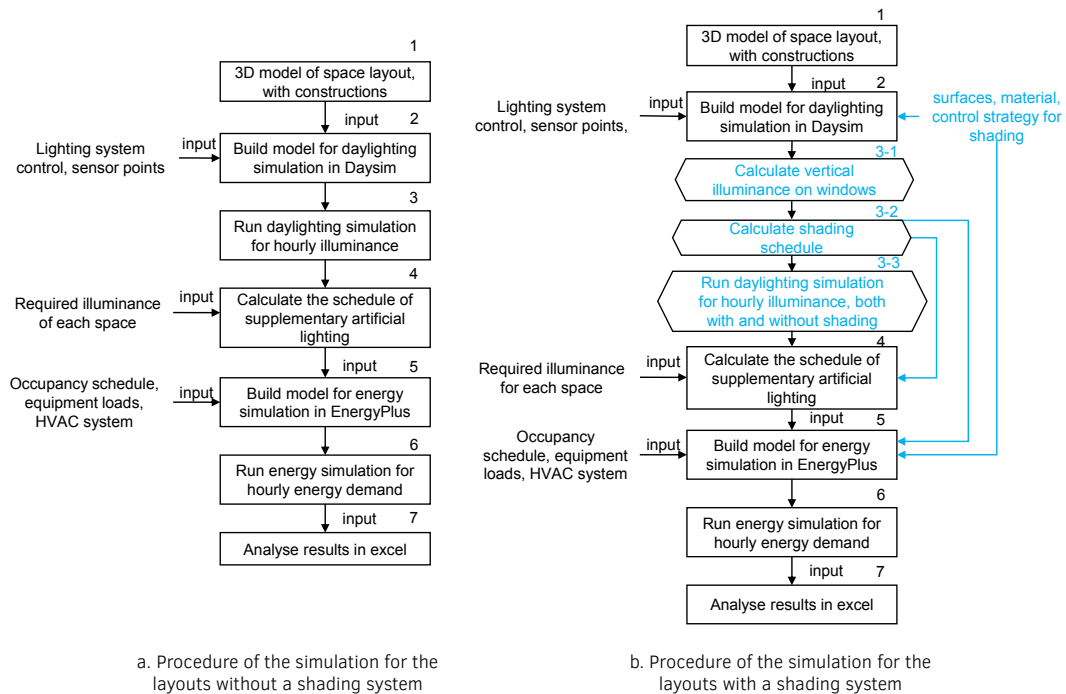

FIG. 3.3 Procedure to integrate daylighting simulation with energy simulation

3.3.2 Simulation model and constructions

The same layouts of the reference building were used for all climates. Regarding the model used for simulation, two models were considered as shown in Figure 3.4: in model-a the WWRs of all rooms are the same, i.e. 40%; in model-b, all rooms have the same façade area, so the WWRs of the rooms with one orientation are 40% and the WWRs of all corner rooms are 20%. Comparing the two models, model-a is closer to reality, as corner rooms normally have higher façade areas than the other rooms. Since the aim of this study is test the isolated effect of space layouts on BEP,

while keeping the other design parameters constant, both models are suitable. As we think model-a is more realistic, model-a with the same WWR in all rooms was chosen for simulation for all three climates.

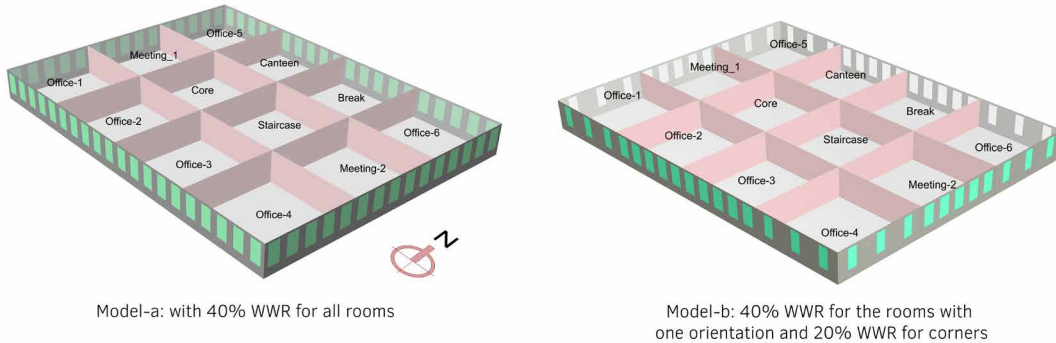

FIG. 3.4 Simulation models for one layout

A WWR of 40% was chosen, in line with the optimal WWR of 30%–45% as recommended for office buildings with shading devices for the climates in Europe covering the latitude of 35°–60° N in [35], which is suitable for Amsterdam and Harbin. For the tropical climate, the WWR of 25% is recommended for office buildings without shading in [36], so a higher WWR is expected for office buildings with shading. Therefore, a WWR of 40% is applied for all climates. The distance from the bottom of the window to the floor is 0.8 m. All windows with the height of 2 m are distributed evenly on all facades, and the distance between two adjacent windows is 0.72 m.

The constructions of walls, windows and floors used in the simulation vary between climates, based on local building design standards and customs, as shown in Table 3.1. The constructions were assigned based on the references of [37–40] for Amsterdam and [41,42] for Singapore. For Harbin, the constructions and materials of glazing and external walls were assigned based on a real project which was constructed in 2018, and the U values were assigned based on [43].

TABLE 3.1 Details of walls, floors and glazing used for the layouts in three climates

Construction of wall and floor			
Name	Layers (from inside to outside)		U value (W/m ² ·K)
Interior wall for all climates	19mm Gypsum board + air space resistance+19mm Gypsum board;		2.56
Interior floor for all climates	Acoustic tile + ceiling air space resistance + 100mm lightweight concrete;		1.45
Exterior wall for Amsterdam [37]	100mm brick + 25mm air cavity + 140mm insulation + 150mm concrete;		0.22
Exterior wall for Singapore [41]	25 mm plaster + 300 mm concrete + 50 mm insulation + 12 mm plasterboard + 12 mm plaster;		0.5
Exterior wall for Harbin	20mm cement mortar + 150mm rigid polyurethane foam + 20mm cement mortar + 200mm concrete + 20mm lime mortar;		0.18 [43]
Glazing properties			
Location	U value (W/m ² ·K)	Visible transmittance	g value
Amsterdam	1.65 [38]	0.76 [40]	0.7 [39]
Singapore	1.6 [42]	0.59 [41]	0.27 [41]
Harbin	2.2 [43]	0.8	0.54
Reflectance of interior surfaces			
Floor	Ceiling	Wall	
0.1	0.8	0.5	

3.3.3 Daylighting simulation and artificial lighting system

The daylight simulation was used to determine the amount of the supplementary artificial lighting needed to reach the required illuminance. In this study, the daylight-linked dimming was used to control the lighting system: the lamp is only switched on when the room is occupied and is dimmed to output the illuminance based on the available daylighting illuminance until the work plane receives the required illuminance. The modelling details are shown below.

3.3.3.1 Test points and simulation parameters for daylighting simulation

The test points for daylighting simulation are distributed evenly in 12 rooms within the layout. These test points are located on a grid resolution of 1 m × 1 m, and the vertical distance from the test point to the base surface is 0.8 m. The reflectance of the interior surfaces is shown in Table 3.1. The Radiance simulation

parameters are as follows [44]: ab (ambient bounces) is 5; ad (ambient divisions) is 1024; as (ambient super samples) is 16; ar (ambient resolution) is 256; aa (ambient accuracy) is 0.1.

3.3.3.2 Target illuminance and properties of the artificial lighting system

As recommended in [45], different functions need different illuminance levels, and the illuminance levels used in this study are as follows: 500 lux for offices, 300 lux for meeting rooms, 200 lux for break rooms and canteens, and 150 lux for staircases and cores. An energy-efficient lamp was used for lighting with the luminaire efficacy of 138 lm/W and initial luminous flux of 4000 lm, which is in accordance with the Philips SM530C L1130 1×LED40S/840 OC [46]. The room index is 2, and it is used to determine the utilisation factor of each room. Calculated based on the photometric data of the lamp and the reflectance of ceilings, walls and floors, the utilisation factor is 0.97. The maximum lighting power density, which is needed for the required illuminance of each room, was calculated based on the 'lumen method' [47]. The density for each room is as follows: 4.7 W/m² for offices, 2.8 W/m² for meeting rooms, 1.9 W/m² for break rooms and canteens, 1.4 W/m² for staircases and cores. The other properties of the lighting system are as follows: the standby power is 1% of the lamp power (29 W), i.e. 2.9 W; the delay time of sensors is 5 minutes; the ballast loss factor is 0%, as LED luminaires do not use ballast.

3.3.3.3 Control of lighting system

As for the control of lighting system, each room was divided into three lighting zones, as shown in Figure 3.5, using the following procedure: (1) the hourly daylight illuminance (without shading) of each test point is summed up for one year; (2) the natural logarithm of the annual value is calculated for each test point; (3) the values of all test points are divided into three domains; (4) all test points within one room are classified into three groups based on the three domains; the corresponding area of each group is one lighting zone. Since the middle rooms do not receive any daylight, no test point is assigned to them. Within one lighting zone, the artificial lighting system was adjusted to meet the target illuminance based on the daylight illuminance of the test point that has the lowest annual daylighting illuminance. The supplementary artificial lighting schedule of each room was calculated as follows: (1) the ratio between the required illuminance, i.e. the difference between the target

illuminance and the received daylighting illuminance, and the target illuminance is calculated for each lighting zone; (2) the illuminance ratio is multiplied by the corresponding area ratio of the lighting zone; (3) the values of three lighting zones are summed up for each room. For the energy simulation, the artificial lighting power calculated for three lighting zones in each room is used as the internal gains for the room.

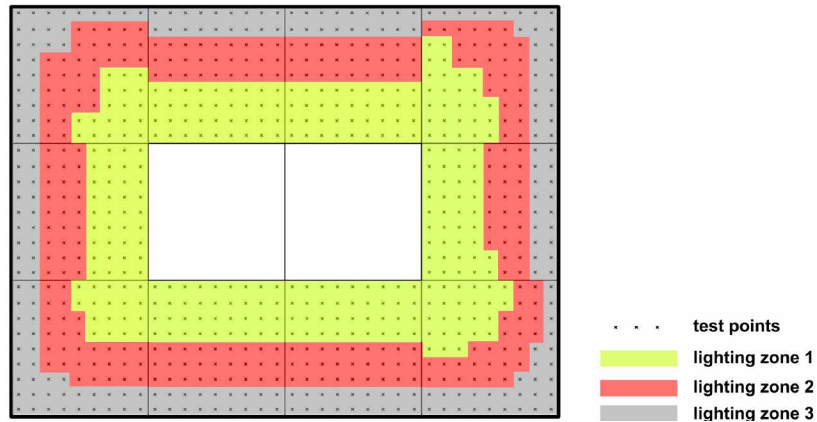

FIG. 3.5 Test points and lighting zones for lighting system control (the two middle rooms do not have daylighting)

3.3.3.4 Shading system

The daylighting performance was investigated both with and without a shading system. In this study, an exterior screen is assumed for each window and is automatically controlled based on the possibility of glare. In corner rooms, shading screens were installed on two facades, and they were controlled separately based on the vertical illuminance on each facade.

Shading material and control strategy

The exterior screen of Dickson sun worker open M005 was selected from [48] and used in this study. Its properties are as follows: the thickness is 0.00055 m; the emissivity is 0.77; its g-value is 0.32; the visible transmittance is 0.31; the diffuse visible transmittance is 0.14; the visible reflectance is 0.60; the heat resistance

is 0.0069; the conductivity is 0.08 W/m·K. The control strategy for shading used in this study is shown in Table 3.2. During the non-cooling period, when a room was occupied and there was glare, the screen was turned on for shading; at the other time the screen was turned off to have more solar gains. During the cooling period, when a room was occupied and had no glare, the screen was turned off for more daylight; at the other time the screen was turned on to have less solar gains.

TABLE 3.2 Control strategy for the shading system

Period	Working period (9:00-17:00)			Off-working period (0:00-8:00, and 18:00-23:00)
	Occupied		Non-occupied	
	Glare	No glare		
Non-cooling period	On (to avoid glare)	Off (for more daylight)	Off (for more solar gains)	Off (to increase solar gains in early morning and late afternoon)
Cooling period	On (to avoid glare)	Off (for more daylight)	On (to reduce solar gains)	On (to reduce solar gains in early morning and late afternoon)

Note: the thermal property of the screen is not considered in this study.

Calculation of the vertical illuminance on windows for shading control

In this study, the shading system was controlled based on the possibility of glare. There are various indicators for glare, varying from the simply one of the illuminance on windows [49] to the specific ones, like BRS glare equation, daylight glare index (DGI), CIE glare index (CGI), CIE’s unified glare rating system (UGR), and daylight glare probability (DGP), as shown in [50]. However, the specific indicators are sensitive to furniture layouts, view directions of occupants, window frames, etc., which differ between different rooms and cannot be specified in this study. So we used the vertical illuminance on windows as the indicator for glare possibility. The set-point for shading is 15,000 lux of the vertical illuminance on windows, as recommended in [49].

3.3.4 Energy simulation

The heating and cooling demand were calculated in EnergyPlus with the ideal loads air system [51]. The details for energy simulation are shown below.

3.3.4.1 Ventilation and infiltration

The outdoor air flow rate is $0.37 \text{ dm}^3/\text{s}\cdot\text{m}^2$ (per floor area) plus $8.89 \text{ dm}^3/\text{s}\cdot\text{person}$, as recommended in [39]. For all climates, a heat exchanger was used with a heat recovery efficiency of 0.7. The humidity threshold is 25%-60%, as recommended in [52]. The infiltration rate is 0.2 air changes per hour and the middle rooms have no infiltration.

3.3.4.2 Temperature set-points for heating and cooling

Different functions have different requirements for the thermal comfort temperature. The temperature set-points for cooling and heating are as follows: 24°C (cooling) and 22°C (heating) for offices and meeting rooms, 26°C (cooling) and 20°C (heating) for canteens and break rooms, 28°C (cooling) and 18°C (heating) for staircases and cores. The set-back points for cooling and heating are the same for all rooms, being 30°C and 15°C respectively. The temperature set-points were assigned based on NEN 16798-1 [52].

3.3.4.3 Internal gains of occupants and equipment

The applied maximum occupancy and equipment load density for each function are shown in Table 3.3. The applied maximum equipment load densities are the values defined in Honeybee for office buildings, which were assigned based on the data collected by the U.S. Department of Energy for Commercial Reference Buildings [53].

TABLE 3.3 Maximum internal gains of different spaces

Spaces	Max. occupancy (persons/room)	Max. equipment load density (W/m^2)
Office	6	6.9
Meeting room	12	4
Canteen	9	48
Break room	9	0.8
Staircase	3	0
Core	3	3

3.3.4.4 Schedule

The occupancy schedule is shown in Figure 3.6. The occupancy schedule differs between functions, as different activities happen at different periods. The average occupancy schedule (the maximum occupancy multiplied with the schedule fraction) of offices for one day is around 0.3, which is in accordance with the Dutch standard NTA 8800 [54]. For the comparability of the results, the same schedules were assumed for the three climates. The maximum occupancy and occupancy schedule were designed in order to get close to the real situation and to show the difference between functions.

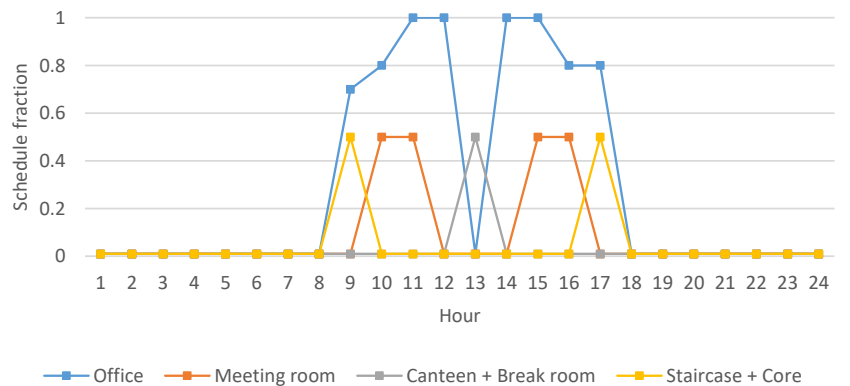

FIG. 3.6 Occupancy schedule for different functions

3.4 Results and analysis

In order to compare the results between layouts, the maximum difference (%), as explained in Section 3.1, was used as the indicator to show the effect of space layouts on BEP. In this section, energy demand was compared, as well as the resulting final energy demand. The **energy demand** (or energy need) for heating or cooling refers to the ‘heat to be delivered to or extracted from a conditioned space to maintain the intended temperature conditions during a given period of time’ [55]. The **final energy** for heating or cooling refers to the energy input to the heating or cooling system to satisfy heating and cooling respectively [55], which is in the form of the energy carrier bought at the meter, such as electricity. Comparing final energy

helps to identify the effect of space layouts on the overall energy use of buildings, as the efficiency of transferring the delivered energy for demand varies between heating, cooling and lighting. Energy demand was obtained from the simulation of EnergyPlus, and final energy was calculated based on some assumptions concerning energy supply system.

3.4.1 Comparison of energy demand

The resulting heating, cooling and lighting demand of all layouts in the three climates are presented in Table 3.4, and they are compared below.

TABLE 3.4 Energy demand of all layouts in the three climates

	Energy demand of Amsterdam (kWh/m ²)						Energy demand of Harbin (kWh/m ²)						Energy demand of Singapore (kWh/m ²)			
	Without shading			With shading			Without shading			With shading			Without shading		With shading	
	H	C	L	H	C	L	H	C	L	H	C	L	C	L	C	L
Layout-a	14.2	12.1	1.8	17.3	4.3	2.2	37.8	36.6	1.3	41.4	16.8	1.7	229	1.5	132	2.1
Layout-b	12.8	11.4	2.7	14.9	4.1	2.9	36.9	36.2	2.2	38.6	16.1	2.5	232	2.2	137	2.8
Layout-c	12.8	11.3	2.8	14.5	4.0	3.0	36.8	36.3	2.4	37.9	16.4	2.6	227	2.2	137	2.7
Layout-d	13.0	11.9	2.4	15.8	4.5	2.8	37.0	36.4	1.9	40.1	16.3	2.3	234	2.2	137	2.7
Layout-e	13.8	12.0	2.4	16.1	4.2	2.6	37.5	37.2	2.0	39.4	17.1	2.2	228	1.8	135	2.4
Layout-f	13.6	12.2	2.2	16.3	4.4	2.5	37.4	37.0	1.6	40.3	17.0	2.0	230	1.8	134	2.4
Layout-g	13.5	12.1	2.7	16.0	4.3	3.0	37.3	36.8	2.2	39.7	16.5	2.5	230	2.3	137	2.9
Layout-h	13.8	12.0	2.3	16.6	4.3	2.7	37.5	36.6	1.8	40.6	16.4	2.2	230	2.0	135	2.6
Layout-i	13.7	11.6	2.1	16.2	4.0	2.3	37.5	36.5	1.6	39.8	16.7	1.8	225	1.5	132	2.1
Layout-j	13.8	11.7	2.0	16.4	4.1	2.3	37.7	36.7	1.5	40.2	16.8	1.8	224	1.4	132	2.0
Layout-k	14.3	12.3	2.1	17.6	4.4	2.5	37.8	36.8	1.5	41.4	16.8	2.0	230	1.8	134	2.4
Absolute maximum difference	1.5	1	1	3.1	0.5	0.8	1	1	1.1	3.5	1	0.9	10	0.9	5	0.9
Maximum difference (%)	11%	8%	35%	18%	11%	27%	3%	3%	46%	9%	6%	35%	4%	37%	4%	31%

Note: The blue value represents the lowest value of a given column, and the bold value represents the highest. H: heating; C: cooling; L: lighting. Absolute maximum difference refers to the biggest difference between the best layout and worst layout (kWh/m²)

3.4.1.1 Overall results of energy demand

Among all maximum differences in energy demand for all cases in Table 3.4, the **lighting demand** has the greatest maximum difference; the maximum differences in heating and cooling demands are significantly lower. The maximum differences in lighting demand is the highest, and the highest values occur in Harbin, being 46% without shading and 35% with shading. The values without shading are higher than the values with shading, and this is because the difference in received daylight is reduced as a result of shading. The maximum difference in **heating demand** is relatively low, and the highest difference occurs in Amsterdam, being 11% and 18% for without shading and with shading respectively. Apparently, the additional internal gains from artificial lighting have a higher influence on the fluctuation of heating demand with the reduction of solar gains. The highest value of the maximum difference in **cooling demand** occurs in Amsterdam, being 8% for without shading and 11% for with shading.

3.4.1.2 Detailed discussion of the results for Amsterdam

This subsection presents the detailed analysis of the results for Amsterdam. The heating, cooling and lighting demand of the layouts without and with shading are shown in Table 3.4 and compared below.

Lighting demand for Amsterdam

Compared to the results without shading, lighting demand of all layouts with shading increases strongly. The maximum difference between the layouts with shading is smaller than between the layouts without shading (27% versus 35%). For both with and without shading, layout-c has the highest lighting demand among all layouts. In layout-c, two offices which have the highest illuminance requirement are oriented North, and the meeting rooms which have the second highest illuminance requirement are located in the middle, where no daylight is available. For both with and without shading, layout-a has the lowest lighting demand among all layouts. In layout-a, offices are located in South and corners, where receive the most amount of daylight.

Heating demand for Amsterdam

Among all layouts both without and with shading, layout-k has the highest heating demand and layout-c has the lowest. The maximum difference in heating demand is 11% without shading and 18% with shading. Generally, the room with a high temperature set-point for heating, office in this study, should be located in South to receive more solar gains, so that one would expect that layout-k would have the lowest heating demand. However, layout-k results in the highest heating demand and layout-c, in which two offices are located in North, results in the lowest heating demand. With further analysis, the reasons for the difference between layout-c and layout-k are found as follows:

- A According to the comparison of heating demand between layout-c and layout-k (Figure 3.7), the difference between the two layouts is mainly caused by the difference occurring in meeting rooms. In layout-c, meeting rooms are located in the middle, where there is not heat loss to the outside, while in layout-k, they are located in the NW and NE corners.
- B The lighting demand, and therefore internal lighting gains, of layout-c is higher than layout-k (see Table 3.4), so the difference in heating demand is partly caused by the artificial lighting gains.

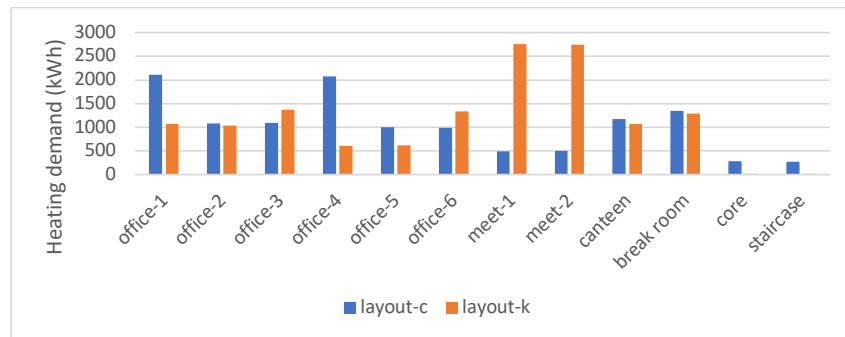

FIG. 3.7 Heating demand of layout-c and layout-k without the shading system for Amsterdam

Cooling demand for Amsterdam

Among all layouts with shading, layout-k has the highest cooling demand and layout-c has the lowest, which is the same as heating demand. The maximum difference in cooling demand is 11%, which is even smaller than heating demand. In summer, solar gains are much higher than lighting gains in Amsterdam. The function with the highest cooling requirement, office in this study, should be located in North, where has less solar gains, and the function with the lowest cooling requirement, core and staircase in this study, should be located in South, which is the case for layout-c. For the cases without shading, the maximum difference in cooling demand is 8%, which is relatively small.

3.4.1.3 Detailed discussion of the results for Harbin

The simulation results of Harbin are shown in Table 3.4 and compared below. The maximum difference in heating demand is 3% without shading and 9% with shading. The maximum difference in cooling demand is 3% without shading and 6% with shading. They are much smaller than the difference in lighting demand, and therefore are not further discussed. Among all layouts, the maximum difference in lighting demand is 46% without shading and 35% with shading. Layout-a has the lowest lighting demand for both without and with shading, which is caused by the offices located in South and corners. Layout-c has the highest lighting demand for both without and with shading. It is because in layout-c two offices are located on the North side and meeting rooms are located in the middle.

3.4.1.4 Detailed discussion of the results for Singapore

The simulation results of Singapore are shown in Table 3.4. The maximum difference in cooling demand is 4% without shading and 4% with shading, which is negligible. Therefore, only lighting demand is compared. Among all layouts both without and with shading, layout-g has the highest lighting demand and layout-j has the lowest, and the maximum difference is 37% for without shading and 31% for with shading. In Singapore, the East and West receive more solar radiation than the North and South, as shown in Appendix 3.i. In layout-j, all offices are located on the East and West side, while in layout-g, most offices are located on the North and South.

3.4.2 Comparison of the final energy

In order to compare the overall energy performance, the energy demand cannot be simply summed up, as they are not in the same type of energy carrier. In order to assess the overall energy performance, energy demand must be converted to final energy, as explained at the beginning of Section 3.4. For all layouts, an air-source heat pump was assumed to be used for heating and cooling. The theoretically ideal COP (COP_{carnot}) [56] was calculated monthly for each climate, based on the supply temperature (35°C for floor heating and 5°C for cooling with chilled water [57]) and the monthly minimum (for heating) and maximum (for cooling) average outdoor temperature. The real COP (COP_{real}) is between 40% and 60% of COP_{carnot} as shown in [56]. So, the COP_{carnot} was multiplied with 50% to obtain the COP_{real} in this study. With the COP_{real} , the final energy for heating and cooling was calculated. For lighting, the artificial lighting demand is already in form of electricity and thereby the final energy for lighting is the same as lighting demand. The sum of the calculated final energy for heating, cooling and lighting for the three climates is shown in Table 3.5. The highest maximum difference in the sum of final energy is 8% for layouts without shading which happens in Amsterdam, and 8% for layouts with shading which also happens in Amsterdam.

TABLE 3.5 The sum of the final energy for heating, cooling and lighting for the three climates

	Final energy for different layouts (kWh/m ²)											Maximum difference (%)
	a	b	c	d	e	f	g	h	i	j	k	
Sum of the final energy of Amsterdam												
With shading	7.7	7.8	7.7	7.9	7.8	7.8	8.1	8.0	7.5	7.5	8.1	8%
Without shading	7.9	8.3	8.4	8.1	8.4	8.1	8.6	8.3	8.0	7.9	8.2	8%
Sum of the final energy of Singapore												
With shading	36.1	38.1	37.9	37.9	37.1	36.9	38.3	37.4	36.1	36.1	36.8	6%
Without shading	60.4	61.9	60.5	62.3	60.6	61.0	61.6	61.2	59.2	59.2	60.9	5%
Sum of the final energy of Harbin												
With shading	21.8	21.3	21.2	21.8	21.6	21.8	21.9	21.9	21.3	21.4	22.1	4%
Without shading	24.1	24.6	24.8	24.4	24.9	24.4	24.8	24.5	24.3	24.3	24.5	3%

Note: The blue value represents the lowest value of a given row, and the bold value represents the highest.

3.4.3 Discussion

To better understand the reasons for the differences between layouts, we analysed the energy demand of each function in different locations, based on the results obtained from the energy simulation.

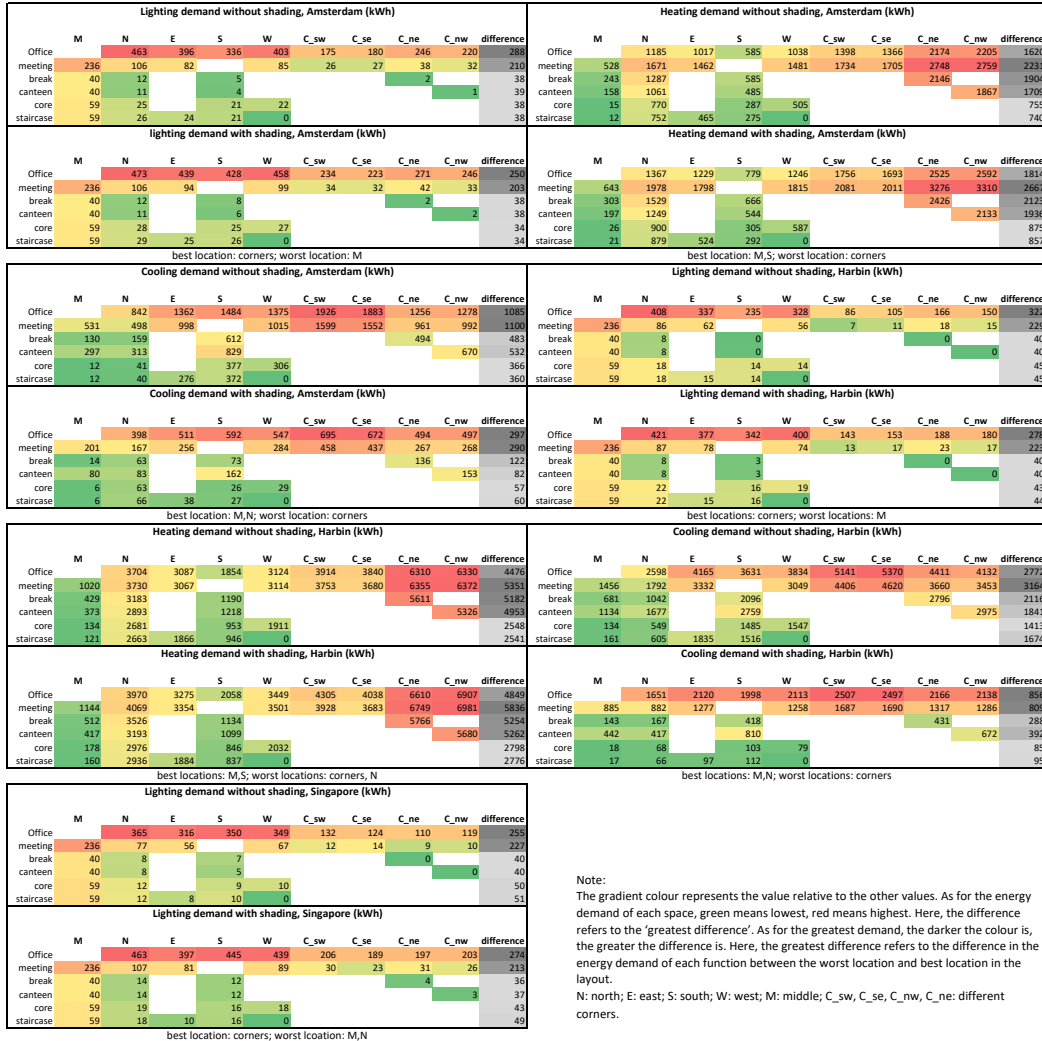

Note:
The gradient colour represents the value relative to the other values. As for the energy demand of each space, green means lowest, red means highest. Here, the difference refers to the 'greatest difference'. As for the greatest demand, the darker the colour is, the greater the difference is. Here, the greatest difference refers to the difference in the energy demand of each function between the worst location and best location in the layout.
N: north; E: east; S: south; W: west; M: middle; C_sw, C_se, C_ne, C_nw, C_ne: different corners.

FIG. 3.8 Energy demand of each function in different locations

In Figure 3.8, the energy demand of each function in each location is presented and the gradient colour represents the value relative to the other values. As shown in the last column of each situation, the **greatest difference** refers to the difference in the energy demand of each function between the worst location and best location of the layout. For example, the greatest difference of offices in lighting demand without shading of Amsterdam is the difference between North (highest) and SE corner (lowest). As shown in Figure 3.8, the same locations can be the best or worst for energy demand among all locations. So the function that benefits the most from the best location should be placed there.

As for the **heating demand** for Amsterdam and Harbin, the greatest differences of meeting rooms, break rooms and canteens are much higher than offices. As for the **cooling demand** for Amsterdam and Harbin, the greatest differences of meeting rooms and offices are much higher than other functions. As for the **best and worst locations** of layouts, corners are always the best for lighting and worst for heating and cooling, and in contrast, the middle is always the best for heating and cooling and worst for lighting (except for offices which cannot be located in the middle). Hence, the layout with the lowest energy demand is the one that allocates the functions, following the order of the greatest differences from high to low, to the locations from best to worst sequentially. The order of the greatest difference should be updated if one location is occupied.

In conclusion, there is a **trade-off** between the highest difference in lighting, heating, and cooling demand for each function in different locations, as well as a trade-off between the best and worst locations in layouts for lighting, heating and cooling demand. The layout with the lowest energy demand is the result of an optimisation process that can be seen as a 'battle for the best location', won by the function that benefits the most from a certain location. It is these trade-offs that make the prediction of the most energy-efficient layout difficult.

3.5 Sensitivity analysis of design parameters

In order to better understand the influence of space layouts on BEP in combination with other building properties, two design parameters were tested for their influence on the maximum difference in each energy demand between layouts of three climates in this section, i.e. WWR and U value.

3.5.1 Sensitivity analysis for different WWRs

In addition to the WWR of 40% in the previous model shown in Section 3.3, two additional WWRs were tested, i.e. 20% and 60%, as shown in Figure 3.9.

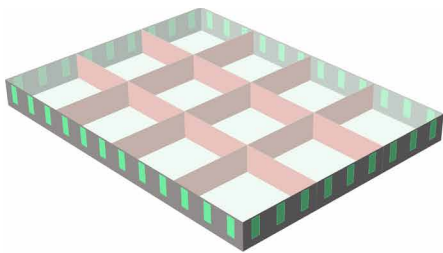

a. The example model with WWR of 20%

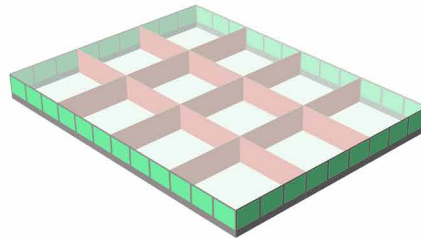

b. The example model with WWR of 60%

FIG. 3.9 Simulation models with WWR of 20% and 60%.

The two WWRs were tested for the 11 layouts in the three climates, and the resulting maximum and minimal energy demand and the maximum difference between 11 layouts are shown in Table 3.6.

TABLE 3.6 Maximal and minimal energy demand and the maximum difference (%) among 11 layouts with the WWR of 20% and 60% in three climates

	Energy demand of Amsterdam (kWh/m ²)						Energy demand of Harbin (kWh/m ²)						Energy demand of Singapore (kWh/m ²)			
	Without shading			With shading			Without shading			With shading			Without shading		With shading	
	H	C	L	H	C	L	H	C	L	H	C	L	C	L	C	L
WWR 20%																
Max	11.3	7.3	3.8	13.2	3.7	3.9	31.8	23.5	3.5	34.3	14.6	3.9	144.8	3.4	111.1	4.0
Min	9.8	6.8	3.0	10.8	3.3	3.4	30.6	22.9	2.4	31.6	13.7	2.9	141.0	2.6	108.9	3.3
Absolute maximum difference	1.5	0.6	0.8	2.4	0.4	0.5	1.2	0.6	1.1	2.7	0.9	1.0	3.8	0.9	2.2	0.6
Maximum difference (%)	13%	8%	21%	18%	12%	13%	4%	2%	33%	8%	6%	25%	3%	25%	2%	16%
WWR 60%																
Max	17.6	16.6	2.2	21.4	5.5	2.4	45.4	49.7	2.0	48.4	21.8	2.3	325.4	1.6	172.3	2.2
Min	16.1	15.1	1.3	18.1	4.9	1.6	44.3	48.3	0.7	44.9	19.0	1.1	311.6	0.7	165.0	1.4
Absolute maximum difference	1.5	1.5	0.9	3.4	0.7	0.8	1.1	1.4	1.2	3.5	2.8	1.3	13.8	0.9	7.3	0.8
Maximum difference (%)	8%	9%	42%	16%	12%	33%	2%	3%	63%	7%	13%	55%	4%	55%	4%	38%

Note: H: heating; C: cooling; L: lighting. Max: the maximal energy demand among 11 layouts, kWh/m²; Min: the minimal value among 11 layouts, kWh/m². Absolute maximum difference refers to the biggest difference between the best layout and worst layout (kWh/m²)

Comparing the results from the simulations with a WWR of 20% and 60% in Table 3.6 with the results using a WWR of 40% in Table 3.4, the following results were found. The maximum difference in thermal energy between layouts hardly changes or changes slightly (in Amsterdam without shading) with the change of WWRs, while the maximum difference in lighting demand between layouts increases highly with the increase of WWRs, for both with shading and without shading. This is because although the absolute maximum differences (kWh/m²) in heating and cooling demand vary between different WWRs, like 2.4 kWh/m² for 20% WWR and 3.4 kWh/m² for 60% WWR in Amsterdam with shading, the value of heating and cooling demand for each layout is much higher than the value of absolute maximum difference, like 21.4 kWh/m² for WWR 60% in Amsterdam with shading. Thus, the relative variation in the maximum difference (%) of heating and cooling demand is little. However, the lighting demand is the opposite. The absolute maximum difference matters relatively more compared to the total lighting demand of each layout. For example, the absolute maximum difference in lighting demand is 0.9 kWh/m² while the total lighting demand of the layout with the lowest demand is only 1.3 kWh/m².

3.5.2 Sensitivity analysis for different U values

The U values used in the previous model as shown in Table 3.1 were chosen based on local regulations and they result in good insulation of the building. The building with poor insulation was tested in this Section to simulate existing buildings which need to be renovated for energy performance improvement, with double U values of external walls and glazing used in the previous model, as shown in Table 3.7.

TABLE 3.7 U values of exterior wall and glazing for poor insulated buildings in the three climates

	U value (W/m ² -K)
Exterior wall, Amsterdam	0.4
Exterior wall, Singapore	1.0
Exterior wall, Harbin	0.36
Glazing, Amsterdam	3.3
Glazing, Singapore	3.2
Glazing, Harbin	4.4

The U values for poor insulated buildings were tested for the 11 layouts in the three climates, and the resulting maximal and minimal energy demand and the maximum difference between 11 layouts are shown in Table 3.8.

TABLE 3.8 Maximal and minimal energy demand and the maximum difference (%) among 11 layouts with U values for poor insulated buildings with the WWR of 40% in three climates

	Energy demand of Amsterdam (kWh/m ²)			Energy demand of Harbin (kWh/m ²)						Energy demand of Singapore (kWh/m ²)						
	Without shading			With shading			Without shading			With shading			Without shading		With shading	
	H	C	L	H	C	L	H	C	L	H	C	L	C	L	C	L
Max	16.1	11.9	2.8	19.6	4.4	3.0	40.8	36.9	2.5	44.4	17.8	2.8	236.5	2.2	140.0	2.9
Min	14.5	10.9	1.8	16.3	3.9	2.3	39.7	35.8	1.2	40.5	15.9	1.7	227.1	1.4	134.6	2.0
Absolute maximum difference	1.5	1.5	0.9	3.4	0.7	0.8	1.1	1.4	1.2	3.5	2.8	1.3	13.8	0.9	7.3	0.8
Maximum difference (%)	10%	8%	34%	17%	12%	25%	3%	3%	51%	9%	11%	42%	4%	38%	4%	30%

Note: H: heating; C: cooling; L: lighting. Max: the maximal energy demand among 11 layouts, kWh/m²; Min: the minimal value among 11 layouts, kWh/m². Absolute maximum difference refers to the biggest difference between the best layout and worst layout (kWh/m²)

Comparing the results from the simulations with the U values for poor insulated buildings in Table 3.8 with the results for good insulated buildings in Table 3.4, it is found that with the change of U values, the maximum differences (%) in heating, cooling and lighting demand are hardly changed in the three climates, for both with shading and without shading. Thus, U values of exterior wall and glazing have little influence on the effect of space layouts on BEP.

3.5.3 Overall conclusion on the sensitivity analysis

This sensitivity analysis has shown that the impact of space layout can be affected by other building properties as well. It was shown that the WWR has a significant impact on the effect of space layouts on lighting demand, but only a minor impact on thermal demand. The impact of U-value on both heating, cooling and lighting, is relatively small, regarding the model used in this study. For case studies with a different (e.g. less compact) geometry, this effect could be different. In general, it indicates that the higher the difference in properties between different locations in a building, the higher the impact of changing the space layout on BEP.

3.6 Conclusions, recommendations and limitations

In this paper, the energy demand of 11 space layouts for an office building were simulated and compared, and their final energy was calculated and compared in three climates with three typical cities (Amsterdam, Harbin and Singapore). Besides, the situations both with and without a shading system were simulated for each layout.

3.6.1 Conclusions

In conclusion, it was found that the optimisation of space layout design can reduce energy demand significantly, especially lighting demand. Besides, the effect of space layouts on building energy performance (BEP) differs between climates.

The effect is the highest in the temperate climate and the lowest in the tropical climate. The maximum difference in **lighting demand** is the highest and the highest value happens in Harbin, being 46% without shading and 35% with shading. The maximum difference in **heating demand** is lower, and the highest value happens in Amsterdam, being 11% without shading and 18% with shading. The maximum difference in **cooling demand** is the lowest, and the highest value happens in Amsterdam, being 8% without shading and 11% with shading. As for the **sum of the final energy for heating, cooling and lighting** using an air-source heat pump, the highest maximum difference happens in Amsterdam, being 8% with shading and 8% without shading. The difference in the sum of the final energy is relatively small, as the final energy for lighting makes up a smaller proportion of the total than heating and cooling. The sensitivity analysis shows that WWRs influence the effect of space layouts on lighting demand highly, while slightly on heating and cooling demand. U values have little influence on the effect of space layouts on all energy demand.

3.6.2 The building physics behind finding the optimal space layout

The study has shown that finding the optimal space layout is not straightforward. Different locations within a layout have different availability of solar radiation and daylighting illuminance, while different functions have different needs in terms of set-points of illuminance, heating and cooling. These needs vary with the occupancy schedule. A good match between available energy and needs results in lower energy demand. Thus, placing the right function in the right location helps to save the energy demand in total. This is the reason why space layout matters for BEP. However, the same location can be the best or worst location for all functions, like the rooms in the middle are best for heating and cooling demand, and corners for lighting demand. There is no space layout where each function is on the location that suits this function best; the best space layout is the result of locating the function that benefits the most from the good locations. Thus, designing a space layout for minimising energy demand is a 'battle' for the best location between functions for who can benefit the most.

3.6.3 Recommendations for building designers and owners

The results of this study indicate that the space layout helps to reduce energy consumption, and it helps to reach a lower operation cost and a smaller HVAC system, while keeping the same construction cost. However, as explained in the

previous paragraph, finding the optimal space layout is a complex process and no simple recommendations like 'locating offices to the South' can be given. In addition, the optimal layout also depends on whether the designer or user prioritises heating, cooling or daylight performance, as the optimal differs depending on the objective. Regarding designing a new building, generally, designers would place functions based on the rule of thumb, like placing offices to the South and canteen to the North. However, this is not the case regarding energy performance. The same location can be the best or worst location for all functions. For instance, the corner is the best for all functions regarding lighting demand and the middle is the best for all functions regarding thermal demand. Generally, designers would think the function with the highest requirements, like the office in this study, should be located in the best location. However, according to the analysis in Section 3.4.3, the sequence of the greatest difference would show a different most important function, like meeting room for heating demand in both Amsterdam and Harbin. In order to determine the greatest sequence, a computational method is necessary, as it is not easily calculated based on experience.

The effect of space layouts on BEP found in this study is not only suitable for office buildings. As long as the functions in the layout have different needs, like set-points and schedules, the space layout plays an important role in saving energy demand of the whole building, like a complex building with multiple functions, including residential function, office and restaurant, or hospitals. So, when designing these types of building, designers should consider space layout design as a method to improve BEP.

3.6.4 Recommendations for further research

For the cases investigated, the effect of space layouts on lighting demand is the highest, and the effect on heating and cooling demand is much lower. This could be influenced by the assumed building properties, like thermal mass, set-points, schedule, and shading control. Moreover, the efficiency of the used lighting system also influences the effect of space layouts on BEP. In this paper, a highly energy-efficient lamp was used, while if an energy-inefficient lighting system is used, the effect of space layouts on the lighting demand would be much higher. With the assumed parameters, the effect on the sum of final energy is relatively small, as the difference in lighting demand has less influence on the total than heating and cooling demand. It is therefore recommended to further study the effect of space layouts on BEP given other assumptions for the parameters that highly influence energy performance, like U values, WWRs, lighting efficiency and control types, and shading control types.

Additionally, in this paper, only the locations of functions within the layout with fixed interior partitions were changed, and more studies are needed to test more **design variables of space layout design**, such as space dimensions, space forms, and interior partitions. Furthermore, this study used a fixed layout boundary, while a flexible boundary is expected to provide more good locations for more functions. The effect of space layouts on BEP is expected to be greater than the results shown in this paper if more design variables are included.

3.6.5 Limitations

There are several factors that could affect the results shown in this paper. The model used in this study does not consider the **surroundings**. The surrounding buildings in the urban context highly influence the amount of solar radiation, daylighting illuminance, and natural ventilation received by different rooms within a layout. The best and worst locations for each energy demand would differ from the ones that are found in this study. Thus, the resulting difference in energy demand between layouts could be highly different from what is found in this paper. This study is conducted within a planar layout, while a **vertical change** in space layouts according to the different vertical conditions resulting from the influence of surrounding buildings would cause a higher difference in energy demand between layouts. Additionally, **natural ventilation** is not considered in the calculation of energy demand. Natural ventilation influences thermal performance highly, especially in summer. Additionally, different orientations of a layout have different conditions of natural ventilation, regarding air pressure, air velocity, and direction. If natural ventilation is included, the difference in thermal demand between layouts would be higher than what is shown in this paper.

Appendix

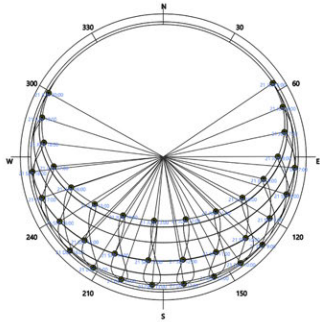

a. Sun path, Amsterdam

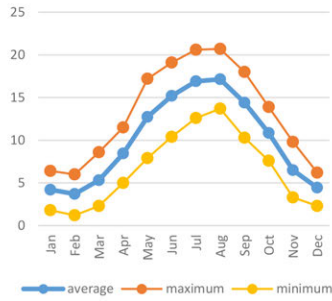

b. Monthly dry bulb temperature (°C), Amsterdam

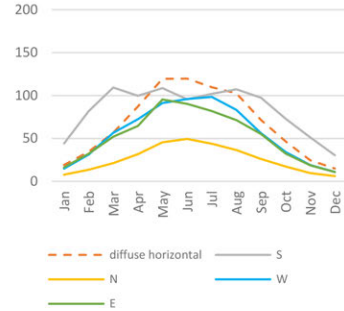

c. Monthly solar radiation (kWh/m2-day), Amsterdam

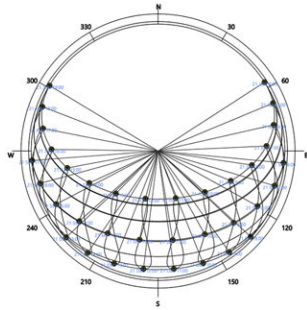

d. Sun path, Harbin

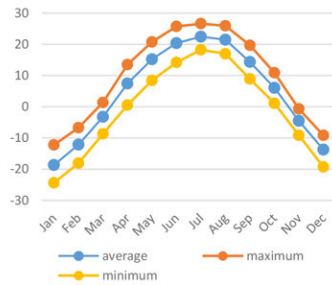

e. Monthly dry bulb temperature (°C), Harbin

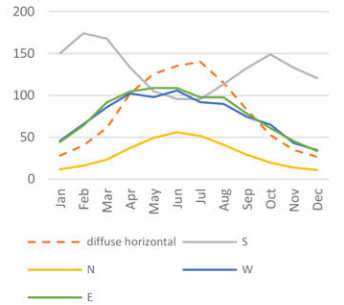

f. Monthly solar radiation (kWh/m2-day), Harbin

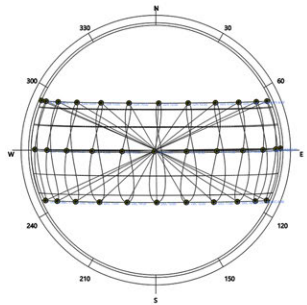

g. Sun path, Singapore

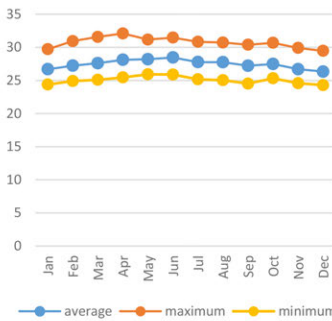

h. Monthly dry bulb temperature (°C), Singapore

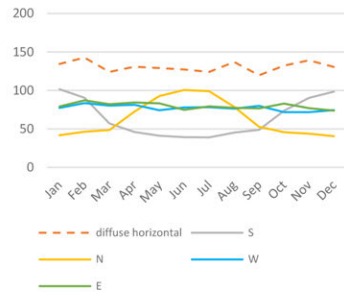

i. Monthly solar radiation (kWh/m2-day), Singapore

Appendix 3.a-3.i. Weather data of the three cities (Amsterdam, Singapore and Harbin)

References

- [1] N. Kohler, S. Moffatt, Life-cycle analysis of the built environment, *Ind. Environ.* 26 (2003) 17–21. <http://bases.bireme.br/cgi-bin/wxislind.exe/iah/online/?IisScript=iah/iah.xis&src=google&base=REPDISCA&lang=p&nextAction=lnk&exprSearch=19108&indexSearch=ID> (accessed December 3, 2018).
- [2] I. Susorova, M. Tabrizzadeh, A. Rahman, H.L. Clack, M. Elnimeiri, The effect of geometry factors on fenestration energy performance and energy savings in office buildings, *Energy Build.* 57 (2013) 6–13. <https://doi.org/10.1016/j.enbuild.2012.10.035>.
- [3] S.B. Sadineni, S. Madala, R.F. Boehm, Passive building energy savings: A review of building envelope components, *Renew. Sustain. Energy Rev.* 15 (2011) 3617–3631. <https://doi.org/10.1016/j.rser.2011.07.014>.
- [4] S. Sadrzadehrafiei, K. Sopian, S. Mat, C.H. Lim, H.S. Hashim, A. Zaharim, Potential Energy and Emission Reduction through Application of Triple Glazing, 2012. <http://www.wseas.us/e-library/conferences/2012/Vouliagmeni/GED/GED-21.pdf> (accessed December 15, 2020).
- [5] E. Rodrigues, M.S. Fernandes, Á. Gomes, A.R. Gaspar, J.J. Costa, Performance-based design of multi-story buildings for a sustainable urban environment: A case study, *Renew. Sustain. Energy Rev.* 113 (2019) 109243. <https://doi.org/10.1016/j.rser.2019.109243>.
- [6] R. O'Hegarty, O. Kinnane, S.J. McCormack, Review and analysis of solar thermal facades, *Sol. Energy.* 135 (2016) 408–422. <https://doi.org/10.1016/j.solener.2016.06.006>.
- [7] G. Pérez, J. Coma, S. Sol, L.F. Cabeza, Green facade for energy savings in buildings: The influence of leaf area index and facade orientation on the shadow effect, *Appl. Energy.* 187 (2017) 424–437. <https://doi.org/10.1016/j.apenergy.2016.11.055>.
- [8] A.H.A. Mahmoud, Y. Elghazi, Parametric-based designs for kinetic facades to optimize daylight performance: Comparing rotation and translation kinetic motion for hexagonal facade patterns, *Sol. Energy.* 126 (2016) 111–127. <https://doi.org/10.1016/j.solener.2015.12.039>.
- [9] D. Lobos, D. Donath, The problem of space layout in architecture: A survey and reflections, *Arquitetura Rev.* 6 (2010) 136–161. <https://doi.org/10.4013/arq.2010.62.05>.
- [10] T. Du, M. Turrin, S. Jansen, A. Van Den Dobbelen, N. Biloria, A Review on Automatic Generation of Architectural Space Layouts with Energy Performance Optimization, in: *Proc. 4th Int. Conf. Build. Energy Environ.*, Melbourne, Australia, 2018: pp. 856–861. <http://www.cobee2018.net/assets/pdf/p/283.pdf> (accessed June 21, 2018).
- [11] F. Musau, K. Steemers, Space Planning and Energy Efficiency in Office Buildings: The Role of Spatial and Temporal Diversity, *Archit. Sci. Rev.* 51 (2008) 133–145. <https://doi.org/10.3763/asre.2008.5117>.
- [12] F. Musau, K. Steemers, Space Planning, Ventilation and Energy Efficiency in Offices, *Int. J. Vent.* 8 (2009) 9–22. <https://doi.org/10.1080/14733315.2006.11683828>.
- [13] C.B. de Souza, S. Alsaadani, Thermal zoning in speculative office buildings: discussing the connections between space layout and inside temperature control, in: *Proc. 1st Build. Simul. Optim. Conf.*, Loughborough, UK, 2012: pp. 417–424. <http://www.ibpsa.org/proceedings/BSO2012/6C1.pdf> (accessed April 11, 2017).
- [14] H. Poirazis, Å. Blomsterberg, M. Wall, Energy simulations for glazed office buildings in Sweden, *Energy Build.* 40 (2008) 1161–1170. <https://doi.org/10.1016/j.enbuild.2007.10.011>.
- [15] I.G. Dino, G. Üçoluk, Multiobjective Design Optimization of Building Space Layout, Energy, and Daylighting Performance, *J. Comput. Civ. Eng.* 31 (2017) 04017025. [https://doi.org/10.1061/\(ASCE\)CP.1943-5487.0000669](https://doi.org/10.1061/(ASCE)CP.1943-5487.0000669).
- [16] H. Yi, User-driven automation for optimal thermal-zone layout during space programming phases, *Archit. Sci. Rev.* 59 (2016) 279–306. <https://doi.org/10.1080/00038628.2015.1021747>.
- [17] E. Rodrigues, A.R. Gaspar, Á. Gomes, Automated approach for design generation and thermal assessment of alternative floor plans, *Energy Build.* 81 (2014) 170–181. <https://doi.org/10.1016/j.enbuild.2014.06.016>.
- [18] R. Baušys, I. Pankrašovaite, Optimization of architectural layout by the improved genetic algorithm, *Civ. Eng. Manag.* 13 (2005) 37–41. <https://doi.org/10.1080/13923730.2005.9636328>.
- [19] J. Michalek, R. Choudary, P. Papalambros, Architectural layout design optimization, *Eng. Optim.* 34 (2002) 37–41. <https://doi.org/10.1080/03052150214016>.
- [20] Bison Office Spaces: Uw Slimme Keuze, (n.d.). <http://bisonoffices.nl/> (accessed January 13, 2019).

- [21] K. Yeang, *The Green Skyscraper: The Basis For Designing Sustainable Intensive Buildings*, Prestel, Munich, London, New York, 1999.
- [22] U.S. General Services Administration, *Workplace Standards Benchmarking*, 2012. www.gsa.gov/cdnstatic/Workplace_Standards_Benchmark.pdf.
- [23] K. Ahmed, M. Carlier, C. Carlier, C. Feldmann, J. Kurnitski, A new method for contrasting energy performance and near-zero energy building requirements in different climates and countries, *Energies*. 11 (2018). <https://doi.org/10.3390/en11061334>.
- [24] EnergyPlus, *Weather Data – EnergyPlus*, US Department Energy. (2016). <https://energyplus.net/weather> (accessed June 25, 2019).
- [25] EnergyPlus, *Weather Data Sources*, 2015. <https://energyplus.net/weather/sources> (accessed October 10, 2019).
- [26] Daysim, 2013. <http://daysim.ning.com/> (accessed October 11, 2018).
- [27] RADIANCE, *Radsite*. Lbl. Gov/Radiance.2016. <https://floyd.lbl.gov/radiance/> (accessed December 9, 2019).
- [28] EnergyPlus | EnergyPlus, (1996). <https://energyplus.net/> (accessed October 11, 2018).
- [29] G. Ramos, E. Ghisi, Analysis of daylight calculated using the EnergyPlus programme, *Renew. Sustain. Energy Rev.* 14 (2010) 1948–1958. <https://doi.org/10.1016/j.rser.2010.03.040>.
- [30] C.F. Reinhart, O. Walkenhorst, Validation of dynamic RADIANCE-based daylight simulations for a test office with external blinds, *Energy Build.* 33 (2001) 683–697. [https://doi.org/10.1016/S0378-7788\(01\)00058-5](https://doi.org/10.1016/S0378-7788(01)00058-5).
- [31] Ladybug Tools, (2018). <https://www.grasshopper3d.com/group/ladybug> (accessed October 11, 2018).
- [32] S. Motamedi, P. Liedl, Integrative algorithm to optimize skylights considering fully impacts of daylight on energy, *Energy Build.* 138 (2017) 655–665. <https://doi.org/10.1016/j.enbuild.2016.12.045>.
- [33] A. Zhang, R. Bokel, A. van den Dobbelssteen, Y. Sun, Q. Huang, Q. Zhang, Optimization of thermal and daylight performance of school buildings based on a multi-objective genetic algorithm in the cold climate of China, *Energy Build.* 139 (2017) 371–384. <https://doi.org/10.1016/j.enbuild.2017.01.048>.
- [34] A. Eltaweel, Y. Su, Controlling venetian blinds based on parametric design; via implementing Grasshopper's plugins: A case study of an office building in Cairo, *Energy Build.* 139 (2017) 31–43. <https://doi.org/10.1016/j.enbuild.2016.12.075>.
- [35] F. Goia, Search for the optimal window-to-wall ratio in office buildings in different European climates and the implications on total energy saving potential, *Sol. Energy*. 132 (2016) 467–492. <https://doi.org/10.1016/j.solener.2016.03.031>.
- [36] J.W. Lee, H.J. Jung, J.Y. Park, J.B. Lee, Y. Yoon, Optimization of building window system in Asian regions by analyzing solar heat gain and daylighting elements, *Renew. Energy*. 50 (2013) 522–531. <https://doi.org/10.1016/j.renene.2012.07.029>.
- [37] H.M. Nieman, *SBR-referentiedetails woningbouw 2015 Studenteneditie*, Foundation Isso, Rotterdam, the Netherlands, 2015.
- [38] Bouwbesluit, Artikel 5.3. Thermische isolatie | BRIS Bouwbesluit Online, (2012). <https://www.bouwbesluitonline.nl/Inhoud/docs/wet/bb2012/hfd5/afd5-1/art5-3> (accessed June 27, 2018).
- [39] L. Itard, *Energy in the Built Environment*, in: E. van Bueren, H. van Bohemen, L. Itard, H. Visscher (Eds.), *Sustain. Urban Environ.*, Springer, Dordrecht, 2012; pp. 113–175. <https://doi.org/10.1007/978-94-007-1294-2>.
- [40] *Windows for High-performance Commercial Buildings*, (2011) 1–3. <https://www.commercialwindows.org/> (accessed November 27, 2019).
- [41] D.J. Keung, *Building Planning and Massing*, Singapore, 2010. <https://www.bca.gov.sg/GreenMark/others/bldgplanningmassing.pdf> (accessed June 24, 2019).
- [42] *Code on Envelope Thermal Performance for Buildings*, Building and Construction Authority, 2008. <https://www.bca.gov.sg/PerformanceBased/others/RETV.pdf> (accessed July 12, 2019).
- [43] China academy of building research, *Gb50189-2015 Design Standard for energy efficiency of public building*, (2015). http://www.mohurd.gov.cn/wjfb/201508/t20150827_224011.html.
- [44] J.A. Jakubiec, C.F. Reinhart, DIVA 2.0: integrating daylight and thermal simulations using Rhinoceros 3D, Daysim and EnergyPlus, in: *Build. Simul.*, Sydney, Australia, 2011; pp. 2202–2209. [https://doi.org/10.1016/0090-2616\(89\)90032-6](https://doi.org/10.1016/0090-2616(89)90032-6).
- [45] Society of Light and Lighting, *Detailed room design information*, in: *Light. Guid. 7 - Off. Light.*, CIBSE, London, UK, 2005; pp. 45–59.

- [46] SM530C LED40S/840 PSD PI5 L1 130 ALU TrueLine, surface mounted - Philips, (n.d.). https://www.lighting.philips.com/ep/prof/indoor-luminaires/surface-mounted/trueline-surface-mounted/910504098603_EU/product (accessed August 7, 2019).
- [47] L. Halonen, E. Tetri, P. Bhusal, eds., Annex 45 Guidebook on Energy Efficient Electric Lighting For Buildings, International Energy Agency, 2010. <http://www.lightinglab.fi/IEAAnnex45/index.html>.
- [48] ES-SO-Database - Database, (n.d.). <https://www.es-so-database.com/index.php/database> (accessed April 24, 2019).
- [49] W. Beck, D. Dolmans, G. Dutoo, A. Hall, O. Seppänen, Guidebook No. 12 - Solar Shading - How to Integrate Solar Shading in Sustainable Buildings, in: REHVA, Brussels, 2010: p. 74.
- [50] J. Wienold, J. Christoffersen, Evaluation methods and development of a new glare prediction model for daylight environments with the use of CCD cameras, *Energy Build.* 38 (2006) 743–757. <https://doi.org/10.1016/j.enbuild.2006.03.017>.
- [51] EnergyPlus, Ideal Loads Air System: Engineering Reference — EnergyPlus 8.0, (n.d.). <https://bigladdersoftware.com/epx/docs/8-0/engineering-reference/page-092.html> (accessed October 12, 2018).
- [52] Netherlands Standardization Institute, NEN-16798-1 Energy performance of buildings - Part 1: Indoor environmental input parameters for design and assessment of energy performance of buildings addressing indoor air quality, thermal environment, lighting and acoustics - Module M1-6, 2015. <https://connect.nen.nl/Standard/Detail/207600?compId=10037&collectionId=0> (accessed March 8, 2018).
- [53] M. Deru, K. Field, D. Studer, K. Benne, B. Griffith, P. Torcellini, B. Liu, M. Halverson, D. Winiarski, M. Rosenberg, M. Yazdani, J. Huang, D. Crawley, U.S. Department of Energy Commercial Reference Building Models of the National Building Stock, 2011. <https://doi.org/10.2172/1009264>.
- [54] NEN, NTA 8800 Energy performance of buildings-Determination method, 2018.
- [55] Netherlands Standardization Institute, NEN-EN 15603 Energy performance of buildings - Overarching standard EPBD, 2013. <https://connect.nen.nl/standard/openpdf/?artfile=550464&RNR=183180&token=1c908652-28d0-48e9-8ff9-58c3b4c72b91&type=pdf#pagemode=bookmarks>.
- [56] F. Meggers, V. Ritter, P. Goffin, M. Baetschmann, H. Leibundgut, Low exergy building systems implementation, *Energy.* 41 (2012) 48–55. <https://doi.org/10.1016/j.energy.2011.07.031>.
- [57] S. Kärkkäinen, E. Oy, Heat pumps for cooling and heating, 2011. http://www.ieadsm.org/wp/files/Exco File Library/Key Publications/HeatPumpReport_final.pdf (accessed July 18, 2019).

4 Gaps and Requirements for Automatic Generation of Space Layouts with Optimised Energy Performance

This chapter is adapted from a journal paper published on 20 May 2020: T. Du, M. Turrin, S. Jansen, A. Van Den Dobbelsteen, J. Fang, Gaps and requirements for automatic generation of space layouts with optimised energy performance, *Autom. Constr.* 116 (2020) 103132. <https://doi.org/10.1016/j.autcon.2020.103132>.

ABSTRACT Due to the critical need for reducing carbon emissions, the demand for energy-efficient building design is urgent. Studies have shown that space layouts affect energy performance considerably. Energy performance optimisation is able to improve energy performance significantly. However, in order to apply energy performance optimisation to space layouts (EPO), abundant layout alternatives are needed. With the development of computational methods, automatic generation of space layouts (GSL) helps to generate abundant layouts quickly. Therefore, combining GSL with EPO is expected to be greatly helpful for energy-efficient design. This paper investigates 10 relevant studies combining GSL and EPO and analyses their gaps. Furtherly, we extend the analysis to the research on GSL and EPO. 7 GSL methods are categorised and evaluated based on 66 studies, and the

requirements for the combination with optimisation are inspected. Regarding EPO, the requirements for energy performance assessment and optimisation are analysed.

ABBREVIATIONS

GSL: automatic generation of space layouts; G-O: automatic generation of space layouts combined with optimisation; EP: energy performance assessment of space layouts; EPO: energy performance optimisation of space layouts; G-EPO: automatic generation of space layouts with optimised energy performance.

4.1 Introduction

Currently, the energy consumption in buildings constitutes up to 40% of the total primary energy consumption in the U.S and E.U. [1]. Performative computational architecture aims at improving building performance by informing the decisions during the design process based on performance evaluation [2]. It includes the comparison of design alternatives based on quantified performance, and the search for well-performing solutions within large sets of design alternatives. The performative computational architecture has shown great potential in energy saving [3]. **Energy performance optimisation** is broadly studied, which aims to select the optimal design with minimal energy use.

Space layout design is one of the design tasks taking place in the ‘scheme design’ and ‘design development’ stages in the early design phase [4], and one of the most important missions in architectural design. In this paper, the space layout is defined as the allocation of different spaces, and it is decided based on the placement of interior partitions as well as exterior walls. Studies have shown that space layouts can affect building energy performance significantly, regarding heating, cooling, lighting and ventilation demands. A comparison of five space layouts for an office building in the UK was made in [5], and resulted in the biggest difference (difference / the highest demand) of 57% in the heating demand for peak winter and 67% in the lighting demand for peak summer. The same layouts were compared in [6], in which the opening state of windows and interior doors were also changed in addition to the space layout, and resulted in the biggest difference of 65% in the air volume of natural ventilation provided through background vents in peak winter. Three layouts were simulated and compared in [7], which resulted in the biggest difference of 52% in the heating demand for one year and 24% in the cooling demand. Two office layouts in Sweden were simulated and compared in [8], in which window to wall ratio (WWR) was also changed in addition to the space layout, and resulted in the biggest

difference of 14% in the heating demand and 57% in the cooling demand. Various layouts for a library building in Turkey were simulated and compared in [9], in which WWR was also changed in addition to the space layout, and resulted in the biggest difference of 19% in the heating demand per day and 20% in the cooling demand per day and 10% in the lighting demand per day. Several layouts for an office building in South Korea were simulated and compared in [10], in which WWR was also changed in addition to the space layout, and resulted in the biggest difference of 8% in the annual energy use and 15% in the predicted mean vote (PMV). Various layouts for a residential building in Portugal were simulated and compared in [11], in which the window orientation and shading size were also changed in addition to the space layout, and resulted in the biggest difference in thermal discomfort of 33% for the buildings with one floor and 29% for the buildings with two floors.

Evins [12] highlighted the benefits of using computational optimisation during design phases to optimise the energy performance of buildings. His extensive review of precedents in computational energy optimisation reveals a large attention on building envelopes, mechanical systems, and energy generation. Among the analysed precedents, the space layout is rarely used. A similar conclusion can be drawn from the review of Ekici et al. [2], which shows the dominance of energy-related objectives in building optimisation design. The study collected the papers relevant to performative computational architecture including form generation, performance evaluation, and optimisation, with the keywords of ‘building design’, ‘architectural design’, ‘evolutionary algorithm’, ‘evolutionary computation’, ‘swarm intelligence’, and ‘swarm optimisation’. This review paper shows that WWR, shading, orientation, window dimension, and building shape are the most commonly used design variables during optimisation, among all the form-finding parameters. Among the collected 100 studies, only 6 studies are relevant to space layout design. According to these reviews, it appears that energy performance optimisation has been studied and applied to different design tasks, while it is rarely applied to space layout design. Based on our review, all design tasks for which energy performance optimisation has been applied are represented in parametric variations. However, representing space layouts in parametric variations is difficult. It requires a systematic generation method, and it is not easy to develop when considering the functionality required by a space layout, like non-overlap (two spaces cannot share the same area), non-overflow (spaces cannot go out the layout boundary), and space connections and adjacencies.

4.1.1 Automatic generation with optimised energy performance

Comparing a large set of alternatives is necessary to identify an optimal design solution. Recent computational development offers an opportunity to automate the generation of design alternatives based on parametric and algorithmic rules. The **automatic generation of space layouts (GSL)** is to use a computational process to generate a huge set of alternative layouts within a reasonable time span. The **automatic generation of space layouts with optimised energy performance (G-EPO)**, which combines GSL with energy performance optimisation is promising and important for future work, as it can produce a large set of layout alternatives within a reasonable time span, and at the same time, it can compare the building energy performance of these alternatives and search for the optimal designs. Performative computational architecture generally includes three parts: form generation, performance assessment, and optimisation [2]. Accordingly, G-EPO includes three parts as shown in Figure 4.1. The part of GSL regards form-finding and includes algorithmic design, associative geometry and parametric design. The part of performance assessment regards two parts, including layout functionality and energy performance, which are to be maximised or minimised as optimisation objectives. The optimisation part is based on optimisation algorithms and regards the computational process that searches for combinations of design variables which output the layout solutions with the optimal values of the performance indicators. Each part has its specific requirements, and they are also affected by others considering their combination. It is necessary to discuss the gaps and requirements for the combination considering their mutual affects.

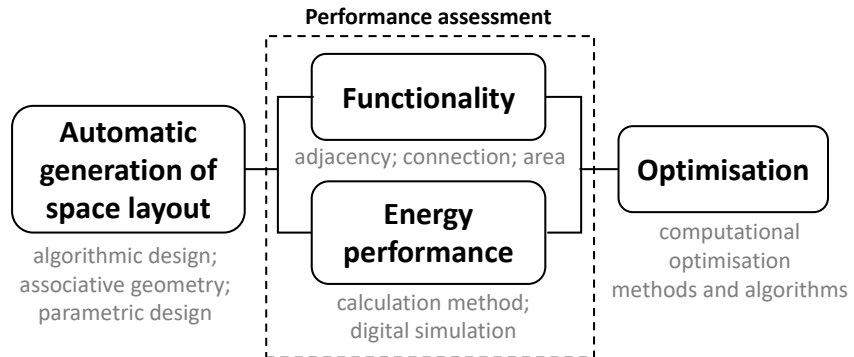

FIG. 4.1 Framework of G-EPO

4.1.2 Research questions

The purpose of this paper is to detect the gaps and requirements of G-EPO. As shown in Figure 4.2, this topic is relevant to three research domains: GSL, energy performance assessment of space layouts (EP), and optimisation. After our first stage of review, only 12 studies are found focusing on G-EPO. In order to pave the way for future research, we extend the analysis to two relevant research areas, i.e. automatic generation of space layouts combined with optimisation (G-O) and energy performance optimisation of space layouts (EPO). The following sub-questions are discussed regarding these two research areas:

- What are the existing GSL methods and what are the criteria for their evaluation?
- What are the requirements for combining GSL methods with optimisation?
- What are the requirements for the energy performance assessment of space layouts?
- What are the requirements for the optimisation of the energy performance of space layouts?

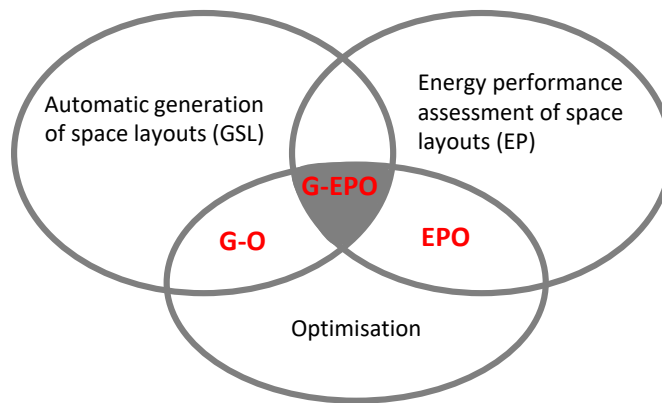

FIG. 4.2 Relevant research domains of G-EPO

4.1.3 Selection of references

The keywords used for searching references are shown in Table 4.1, dividing into space layout, energy, automation. These three terms are used to collect references for Section 4.2 (G-EPO), and the terms of space layout and automation are used for Section 4.3 (G-O). The references for Section 4.2 are also used for Section 4.4 (EPO). We limit the discipline to architectural design. Although some studies used space layout as the keyword, they actually belong to urban planning like in [13], or neighbourhood planning like in [14]. So we eliminate these studies from the collected references. Another similar concept, facility layout [15], is also easy to be confused with, which has a much wider scope, ranging from the assignment of activities to cities, sites, campus, and buildings [16], to the location of facilities in manufacturing systems [15] and in organisations [17]. In this paper, the studies with the keyword of facility layout which focus on architectural design were selected. Totally, 12 studies are found for G-EPO, and 66 studies are found for GSL.

TABLE 4.1 Keywords used for searching references

Term (space layout)		Term (energy)		Term (automation)
Space layout	and	Energy use	and	Automation
Space planning		Energy performance		Optimisation
Interior layout		Energy saving		Solution exploration
Space allocation		Green building		Generation
Floor plan		Sustainable building		
Spatial layout				
Facility layout				

4.2 Literature review on G-EPO

We find 12 studies focusing G-EPO. We select 10 of them for detailed review, as the energy indicators used in the other two studies are only relevant to occupant comfort [18,19]. Although some studies changed layout boundary forms and dimensions like in [20], they are not analysed in this review, as their interior space layouts were not changed correspondingly. The review presented herein focuses on the layout generation, energy performance assessment and optimisation. It provides a systematic analysis of the collected references in order to identify the following problems (Table 4.2):

- the information of the generated layouts: floors of generated layouts, whether the method needs predefined boundary or not, and the generated space form;
- the methods used to represent space layouts (layout representation);
- the design variables meaningful for the layout functionality and/or for the energy performance of the designs;
- the optimisation objectives and constraints for the layout functionality;
- the calculation methods and/or tools for energy performance;
- the optimisation objectives for the energy performance of the designs;
- the optimisation algorithms used for the optimisation process;
- the resulting energy performance improvement (EPI).

TABLE 4.2 Studies relevant to G-EPO

Ref.	Author	Year	Floor	Pre	Form	Layout representation	Design variables	
[21]	Boonstra et al.	2018	Mul	No	Rec	Cell & coordinates	Space location and dimension;	
[22]	Schwartz et al.	2017	mul	Yes	Rec	Coordinates	Space location and dimension; WWR;	
[23] & [9]	Dino; Dino & Ucoluk;	2017	Mul	Yes	Pol	3D matrix	Functionality: space index in 3D location matrix	Energy performance: space location; space width-length-height ratio; WWR
[24] & [25] & [26]	Rodrigues et al.	2014	Sin & Mul	No	Rec	Coordinates	Functionality: space size and position; positions of windows and doors; space connectivity; position of floor;	Energy performance: boundary dimension; boundary orientation; window dimension; space location and dimension; shading dimension;
[10]	Yi	2016	Sin	Yes	Rec	3D matrix	boundary dimension; space location and dimension; WWR;	
[27]	Baušys & Pankrašovaite	2005	Sin	No	Rec	Coordinates	boundary dimension; space location and dimension; window location and dimension;	
[28]	Michalek et al.	2002	Sin	Yes	Rec	Coordinates	space location and dimension; space connectivity; window location and dimension;	
[29]	Caldas	2008	Mul	No	Rec	/	space dimension; space height; roof tilt and directions; clerestory window under roof; window dimension;	
[30]	Sleiman et al.	2017	Mul	No	Rec	Coordinates	space location; space dimension; location of corridors (space are aligned to corridors);	
[31]	Su & Yan	2015	Sin	No	Rec	3D matrix	locations of patient rooms	

Note:

Floor: the floors of generated layouts; Pre: whether the predefined boundary is necessary or not; For: generated space form; Opt: optimisation algorithm; EPI: resulted energy performance improvement; Mul: multi-floors; Sin: single floor; Pol: polygon except for rectangle; Rec: rectangle; NSGA-II: non-dominated sorting genetic algorithm-II; SO: sequential optimisation; SA: simulated annealing; GA: genetic algorithm; SQP: sequential quadratic programming; EA: evolutionary algorithm; PMV: predicted mean vote; WWR: window to wall ratio; '/': not mentioned or not included.

	Objectives/constraints for functionality	Energy calculation methods and/or tools	Objectives for energy performance	Opt	EPI
	non-overlap; non-gap;	Toolbox of C++ with Resistor-capacitor-networks	Heating and cooling demands;	/	H+C: 10%
	Layout area, number of stories, number of rooms, width and length of each room; adjacency matrix;	jEPlus (a user interface of EnergyPlus)	annual district heating and cooling consumption;	NS-GA-II	/
	space area; compactness of spaces; regularity: limit space corners; convexity: keep spaces as convex; façade preference of spaces; floor preferences of spaces; spaces adjacency; spaces separation;	OpenStudio	sum of annual heating, cooling and lighting energy demands; daylighting autonomy;	NS-GA-II	H: 23%; C: 25%; L: 11%
	connectivity and adjacency; non-overlap; opening orientation; floor dimensions; compactness; non-overflow;	Toolbox of Java integrated with EnergyPlus (acknowledging this by inquiring the author)	thermal discomfort of different spaces;	SO	33% -29%
	space connection; non-overlapping;	Ecotect	annual heating and cooling energy demands; PMV; interior daylight level; interior shading;	SA	H + C: 7.7%; PMV: 13%
	non-overlap; non-overflow; connectivity; minimise space area; minimal natural lighting for some spaces;	simplified annual calculation	annual heating cost; annual lighting cost;	GA	/
	non-overlap; specific path, connectivity, external wall; envelope; wasted space; hall size; access-way size;	simplified monthly calculation	annual lighting, heating and cooling cost;	SA & SQP	/
	adjacencies; dimensional constraints; language intensions; explicit and implicit relationships;	DOE 2.1	energy intensity use (annual energy use and space area)	GA	/
	floor preference of space; spaces be clustered horizontally or vertically; traveling distance; space area;	TECT within BIM, following EN ISO 16798-1	energy demand of heating and cooling;	EA	H+C: 8.3%
	nursing traveling distance;	DIVA (with DAYSIM as engine)	daylight illuminance;	GA	/

4.2.1 Methodology of G-EPO

There are mainly two methodologies used in these reviewed 10 studies. In the studies of [9,21,23–26], the process of G-EPO is clearly separated into G-O and EPO phases, as shown in Figure 4.3. The workflow is as follows:

- G-O: the automatic generation of space layouts combined with optimisation. It includes three steps: first, choosing an appropriate method to represent space layouts; second, fitting the representation of spaces to a suitable generation method and generating the variants of space layouts; third, evaluate the generated space layouts in terms of the requirements of the layout functionality, like adjacency, connection, and area, and deciding whether the stop criterion is met. If yes, passing the layout to the next phase; if not, transforming the layout to find a better solution.
- EPO: the energy performance optimisation of space layouts. It includes four steps: first, selecting the appropriate layout from G-O; second, building a 3D building model based on the layout; third, calculating the energy performance with necessary building information, like HVAC system, internal gains, and materials; fourth, evaluating its building energy performance based on the calculation results, and deciding whether the stop criterion is met. If yes, passing the layout as the final layout; if not, transforming the layout to find a better solution. After the iterations of optimisation, the passed layouts are the final layouts.

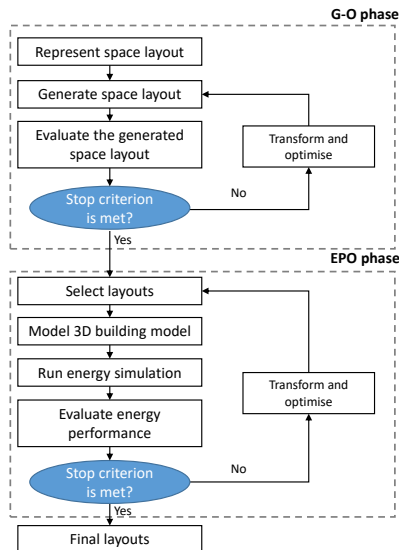

FIG. 4.3 Workflow of G-EPO, used in [9,21,23–26]

In the studies of [10,22,27–31], there is not a clear separation between G-O and EPO. Space layouts are generated first; then the energy performance of the generated layouts is calculated; after that, the optimisation algorithm is used to find the optimal layout (Figure 4.4). However, with this method, the energy performance of each generated space layout needs to be calculated, resulting in time consuming calculations. Besides, users need to predefine the rough layout at the beginning. So, the generated layouts with this method have narrower variation than with the first method. In the studies of [30,32], the used method following this workflow was called semi-automation.

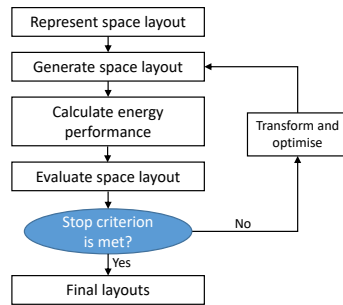

FIG. 4.4 Workflow of G-EPO, used in [10,22,27–31]

4.2.2 Generated layouts and layout representation method

The studies of [21–23,26,29,30] developed the building into multi-floors, while the other studies [10,27,28,31] limited the building to one floor. The studies of [21,24–27,29–31] did not need to predefine a layout boundary, while it was necessary for the others. Most of these studies generated rectangular spaces, while Dino [23] generated polygonal spaces although they were combined rectangles. Two layout representation methods were used to generate layouts: one method used coordinates to represent the location and dimension of spaces [22,24–28,30]; the other method used a 3D matrix to represent spaces and their locations [9,10,23,31]. The study of Boonstra et al. [21] used the combination of the two methods.

4.2.3 Design variables

Some studies limited the variants within a fixed layout boundary, in which only the design variables relevant to interior space layouts were changed [9,10,23]. The other studies did not limit the change of the boundary, in which the change of space locations and dimensions results in the transformation of boundaries. There is a clear separation between the **design variables** for functionality and the ones for energy performance in [9,23–26]. For instance, the space index was only changed for functionality, while WWR was only used for energy performance in [9,23]. The design variables in the collect 10 studies are not uniform: some only used space locations and dimensions [21,30,31], while some also included window dimensions and locations [9,10,22,26–29] and shading dimensions [26].

4.2.4 Objectives of optimisation

Similar to the design variables, there is also a clear separation between the **optimisation objectives** for functionality and energy performance. The objectives for functionality include non-overlap, non-overflow, connectivity and adjacency between spaces, space area, boundary compactness, and traveling distance. The objectives for energy performance include the energy indicators of lighting, heating, cooling, and ventilation, and the comfort indicator of PMV, as well as the daylighting indicators of daylighting autonomy, interior daylight level, and daylight illuminance.

4.2.5 Energy performance calculation method

Most studies calculated energy performance, except for the study of [31]. In contrast, only several studies [9,10,31] calculated daylighting performance. The tools used for daylighting performance assessment include EnergyPlus, Ecotect and Daysim. Regarding the methods for energy performance calculation, the used methods can be classified into the steady-state calculation method [27,28,30] and dynamic simulation method. Regarding the steady-state calculation method, simplified calculation formulas are used to calculate the energy consumption with empirically determined gain and loss correlation factors, and they are easily to be integrated with the generation of space layouts as well as optimisation. Regarding the dynamic simulation method, the tools used for simulations are capable of the integration with the generation of space layouts and optimisation. For instance, Dino and Ucoluk [9] used OpenStudio and Schwartz et al. [22] used jEPlus (a user

interface of EnergyPlus) [33], and they customised and extended the tools to couple the parametric simulation with optimisation; Su and Yan [31] used DIVA [34] (a plugin of Grasshopper), and they integrated the plugin with the generation process and the other plugin for optimisation (Galapagos) in Grasshopper. In addition, a toolbox was developed and coded by Rodrigues et al. [26] in JAVA and Boonstra et al. [21] in C++. Rodrigues et al. [26] used an IDF Parser library to edit the IDF file which was further used in EnergyPlus. Boonstra et al. [21] built the resistor-capacitor-network to simulate the thermal building behaviour, then the network was further integrated with the generation and optimisation program.

4.2.6 Optimisation algorithm

Most studies had multi-objectives, while the studies of [22,29] had one objective. Among the multi-objective studies, most studies converted multi-objectives to a single objective by assigning different weight factors to different objectives [10,26–28,30,31], with which the optimisation results highly depend on the predefined weight factors. Regarding optimisation algorithms, evolutionary algorithms were used in [9,22,27,29–31] and Simulated Annealing was used in [10,28], while the direct search with a sequential optimisation method was used in [26].

4.2.7 Energy performance improvement and conclusions

Based on the results of the 10 studies for detailed review, the highest improvements in the heating, cooling and lighting demand are up to 23% [9], 25% [9] and 11% [9] respectively. This shows that G-EPO is promising to improve building energy performance. Two methods of G-EPO were used (Figure 4.3 and 4.4), and we formulate them as follows: in the first method, functionality is optimised first and then energy performance is optimised (Figure 4.5.a); in the second method, functionality and energy performance are optimised as the same time (Figure 4.5.b).

However, only 12 studies are found relevant to G-EPO. The limitations of the collected studies are apparent: in the G-O part, only several automatic generation methods were used; in the EPO part, these studies used various energy assessment methods regarding design variables, energy indicators and simulation methods, and they were not uniform. Thus, we review and analyse G-O and EPO separately in Section 4.3 and Section 4.4, in order to find solutions to these limitations.

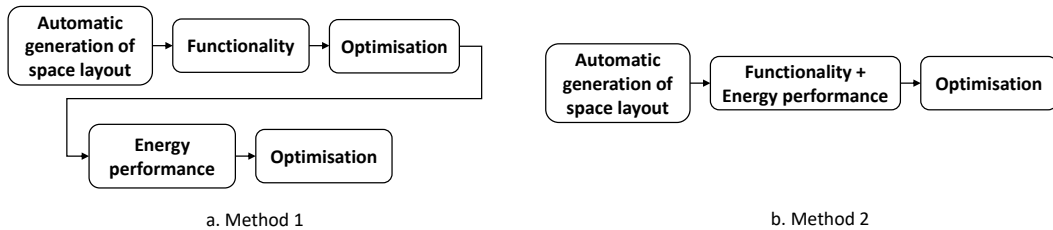

FIG. 4.5 Two methods of G-EPO

4.3 **GSL method: categorisation and combination with optimisation**

Research on GSL started around fifty years ago [35]. There are several review papers on GSL. Helme and Derix [36] collected the projects using GSL in practice; Dutta and Sarthak [37] solely focused on the application of evolutionary computing approaches for space layout design and did not categorise the GSL methods; Nassar [38] discussed the advances in graph theory and analysed their possibilities to be applied to architectural space layout design. The following review studies focus on the methods used for GSL: Frew in 1980 [39] categorised the methods based on whether the boundary was varied or not and how to change space dimensions; Hsu and Krawczyk in 2003 [40] introduced the methods used for space-planning programs separately regarding adjacency, representation, and different actions used among the design process; Lobos and Donath in 2010 [41] collected some relevant studies, but did not categorise the GSL methods; Calixto and Celani in 2015 [42] focused on the used evolutionary algorithms used for GSL. These studies lack the systematic analysis and categorisation of GSL methods. Some of them either only introduced some examples, and some separated the methods either only for representation or only for generation, and the others focused on the evolutionary algorithms. This part of this paper aims at categorising the GSL methods, from the perspective of the generation process of space layouts, considering both representation and generation.

In our previous paper, we classified 4 GSL methods [43]. In this section, 66 studies are found focusing on GSL, and 22 are analysed in detail (Table 4.3) regarding the information of generated layouts, layout representation, layout generation, constraints and objectives for optimization, and optimization algorithm. We categorise them into 7 GSL methods and explain them in terms of layout representation and generation. After that, these methods are evaluated. As most studies used optimisation for layout functionality, in the last part, the requirements for the combination with optimisation are analysed.

TABLE 4.3 Analysis of references to elaborate different GSL methods

GSL method	Ref.	Author	Year	Pre	Floor	Form	Elements to represent space layouts
Physically based method	[44]	Arvin & House	2002	No	sin	rec	coordinates of centre point of spaces; distance of edges to the centre point; spring to represent the distance;
	[45]	Guo & Li	2017	yes	mul	rec	location of spaces; distance between spaces;
Mathematical programming method	[24]	Rodrigues et al.	2013	No	sin	rec	size and position of spaces; positions of windows and doors; connectivity between spaces; position of floor plan;
	[46]	Nagy et al.	2017	Yes	sin	pol	edge of spaces; location of spaces; arrangements of desks; location of amenity spaces;
	[47]	Medjdoub & Yannou	2000	No	mul	rec	size and position of spaces; location of windows;
Graph-theory aided method	[48]	Verma & Thakur	2010	Yes	mul	rec	index in location matrix; doors location; area; length; width; area to perimeter ratio;
	[49]	Chatzikonstantinou	2014	No	mul	rec	position of space centre; width and length of spaces;
	[19]	Lobos & Trebilcock	2014	Yes	sin	rec	position of nodes;
	[50]	Hua	2016	Yes	sin	pol	location of spaces;
	[51]	Nourian et al.	2016	Yes	sin	rec	location of point seeds
	[52]	Wong & Chan	2009	No	sin & mul	rec	nodes for spaces; edges for adjacencies;
	[53]	Shekhawat	2015	Yes	sin	rec	location of spaces; adjacencies;
Cell assignment method	[18]	Yi & Yi	2014	Yes	mul	rec	space adjacency; space index in location matrix;
	[23]	Dino	2016	Yes	mul	pol	interior partitions; dimensional ratio of spaces;
	[54]	Yeh	2006	Yes	mul	rec	locations of spaces; weight of adjacencies between spaces;
	[55]	Gero & Kazakov	1998	Yes	mul	pol	location of spaces, defined in genotype;
Space splitting method	[56]	Das et al.	2016	Yes	sin	rec	index of spaces in data tree
	[57]	Koenig & Knecht	2014	Yes	sin	rec	index of spaces in data tree
Occupant-trace based generation method	[58]	Ghaffarian et al.	2018	Yes	mul	irre	agent's wander rate; separation; cohesion; alignment force; collision;
Machine learning method	[59]	Huang & Zheng	2018	Yes	sin	rec	/
	[60]	Sharma et al.	2017	No	sin	rec	/
	[61]	Chaillou	2019	Yes	mul	sin+irre	/

Note:

Floor: the floors of generated layouts; Pre: whether the predefined boundary is necessary or not; Form: generated space form; Opt: optimisation algorithm; Mul: multi-floors; Sin: single floor; Pol: polygon except for rectangle; Rec: rectangle; Irre: irregular;

ES: evolutionary strategy; SHC: stochastic hill climbing; MOGA: multi-objective genetic algorithm; EH: enumeration heuristic; GA: genetic algorithm; NSGA-II: non-dominated sorting genetic algorithm-II; SA: simulated annealing; EA: evolutionary algorithm; NN: neural networks; GP: genetic programming;

'/': not mentioned or not included; **: the multi objectives are converted to single objective with weighted-sum approach.

Among the actions for generation, the ones used for optimisation are marked in red.

Among all the generation methods, the generation process of machine learning method is different from others, which cannot be divided into representation, generation, and optimisation. So these information is not included for machine learning method in this table.

Actions for generation (actions to change design variables for optimisation)	Constraints and objectives	Opt
adjust attraction and repulsion strength; change the coordinates of spaces and edges;	space adjacency; space separation; orientation; control shape irregularity by alignment and offset; space area; space area proportion; non-gap;	/
adjust attraction and repulsion strength; swap space locations; compress building geometry;	Space connections; dimension; shape; building shape;	ES
change space location; rotate along space centre; stretch the space dimensions; mirror opening locations;	connectivity and adjacency; non-overlap; opening orientation; floor dimensions; compactness; non-overflow;	ES & SHC;
change space location and dimensions;	adjacency preference; work style preference; amount and distribution of high-activity zones; sight lines distribution to other desks; daylight amount; unobstructed view to outside;	MOGA
change space vertex coordinates and space dimensions;	domain and ratio constraints; space connection; space adjacency; orientation; minimise wasted spaces; non-overflow; non-overlap; non-wasted space;	EH
change the index of spaces in location matrix; vary the wall where doors are located; use Dijkstra's algorithm to find the shortest path; change dimensions of layouts;	minimise evacuation time;	GA
change the position of space centre; use Voronoi to generate rectangle spaces; change the locations of centre points;	maximise area; minimise cost; maximise proximity or separation between spaces;	NSGA-II
change the space locations; apply yED to create final layouts;	temperature; illumination; percentage of exterior room area; minimise noise;	/
predefine layouts; detect regions from graphs; assign spaces to the regions; change locations of spaces;	space area; adjacencies between spaces;	SA
generate adjacency graph; generate a Tutte connectivity graph; use attraction and repulsion force to adjust graph; generate Dual graph; add dimensions to the graph;	/	/
change the space index in adjacency matrix; transfer matrix to Dual graph; add dimensions to the graph;	space adjacency; budget; adjacency; relative area ratio of spaces; function deficient;	EA
assign spaces to predefined boundary with spiral-based algorithm; finalize layouts by grouping spaces.	minimise wasted space; space adjacency;	/
assign spaces to grids; change space index in location matrix;	space adjacency; space area; PMV; daylight level; interior/ exterior shading;	SA
assign spaces to voxels; change space locations to avoid overlap and waste space; change space index in the location matrix;	space area; compactness of spaces; regularity; limit space corners; convexity; keep spaces as convex; façade preference of spaces; floor preferences of spaces; adjacency between spaces; separation between spaces;	EA
assign space to grids; change space index in location matrix;	site preference; adjacency; space location feasibility;	NN & SA
assign spaces to layout based on assignment pattern; change values in genotypes;	minimise travel distances between spaces; minimise travel costs between spaces;	GA
split layout based on data tree;	maximise patient beds; minimise nurse travel distance; maximise connectivity to the existing building; minimise view impedance;	/
split layout based on data tree structure; change layers and values in data tree;	adjacency between spaces;	ES & GA & GP
generate circulation pattern based on agent trace simulation; assemble negative space as functional space;	avoid view blocking;	/
/	/	/
/	/	/
/	/	/

4.3.1 Design requirements for layout functionality

The design requirements for layout functionality should be satisfied by GSL. Generally, these requirements can be classified into two groups: topological requirements and geometric requirements [24,47], as shown in Table 4.4. Topological requirements refer to the relative relationship between spaces, including connection, adjacency, and separation between spaces, as well as orientation preferences. Geometric requirements are the ones relevant to dimensional information of spaces and the layout boundary, including width, depth, length, area, and compactness. Additionally, non-overlap and non-overflow should also be satisfied: non-overlap means that two spaces cannot overlap each other; non-overflow means that spaces cannot overflow the layout boundary.

TABLE 4.4 Requirement for layout functionality

Topological requirement	Geometric requirement
Space connection	Width, length and height of space
Space adjacency	Width, length and height of boundary
Space separation	Space area
Orientation preference	Layout area
	Space compactness
	Boundary compactness
	Non-overlap
	Non-overflow

4.3.2 GSL methods categorisation

Based on the analysis in Table 4.3, 7 GSL methods are categorised. These methods are explained as follows.

4.3.2.1 Physically based method

In this method, space layouts are generated by applying physical forces to the spaces. The layout generation process is reformulated to a process to find the equilibrium between different forces, for instance, the attraction and repulsion in a spring system [44,45]. In this method, a space is represented as a circle or rectangle, and the connection between spaces is represented by the string between

circles or rectangles (Figure 4.6.a). Regarding the topological resolution, spaces are represented as circles, and attraction and repulsion forces are applied to strings until the equilibrium is reached (Figure 4.6.b). The attraction and repulsion forces are illustrated in Figure 4.6.e. The strength of the forces represents the quantitative value added to these. A higher attraction strength means a stronger connection between two rooms, and a higher repulsion strength means a weaker connection between two rooms. Regarding the geometric resolution, space locations are changed by designers, and with this action, the overlaps and gaps between spaces can be removed and the adjacencies and connections between spaces can be changed (Figure 4.6.c). Regarding the final layout, users need to manually finalise the layout to satisfy all requirements, like aesthetic intentions (Figure 4.6.d). Forces mainly work on space centres, while they can also work on space edges to change the space form [44]. Some plugins in Grasshopper can help to simulate the physical motions, like Kangaroo [62].

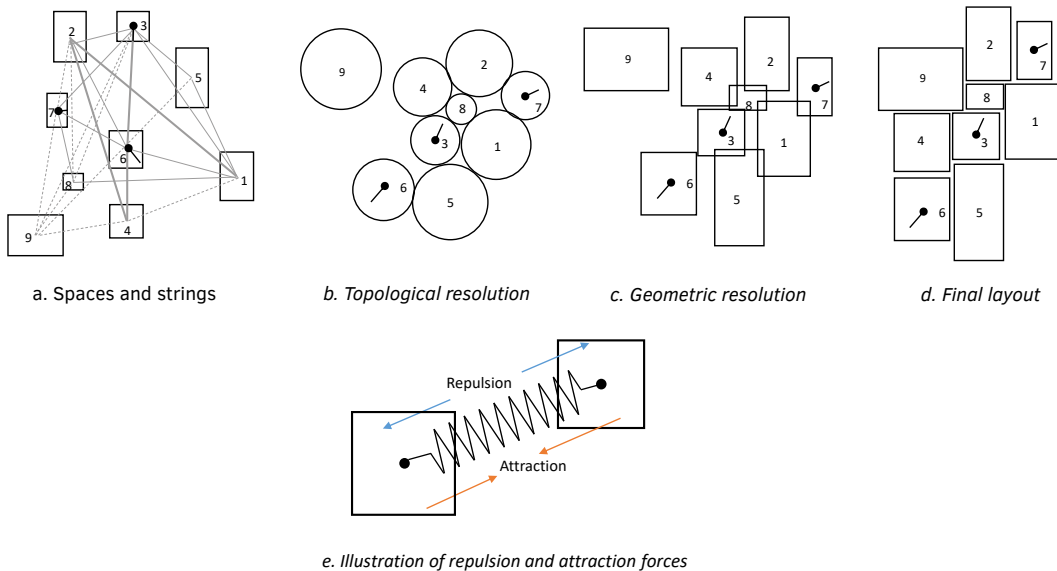

FIG. 4.6 Generation process in [44] (also the source of images)

4.3.2.2 Mathematical programming method

In this method, the design parameters of space layouts and the requirements for layout functionality are transformed into formulas [24,28]. Space locations are represented with the coordinates of centre points, and space connections and adjacencies are controlled by the relative distance between two centre points (Figure 4.7.a). The design requirements, like non-overlap and non-overflow, are transformed into constraints, and expressed as mathematical formulas (Figure 4.7.b). By changing space locations and dimensions, the feasible layouts are obtained by satisfying all constraints (Figure 4.7.c).

$$R_i(x_i, y_i, w_i, h_i);$$

$$\begin{aligned} d_x(R_1, R_2) &= \max\{V_x(R_1), V_x(R_2)\} - \min\{V_x(R_1), V_x(R_2)\} \\ &- w(R_1) - w(R_2) \end{aligned}$$

$$\begin{aligned} d_y(R_1, R_2) &= \max\{V_y(R_1), V_y(R_2)\} - \min\{V_y(R_1), V_y(R_2)\} \\ &- h(R_1) - h(R_2) \end{aligned}$$

a. Space location and dimension, and distance between spaces

$$f_2(l) = \sum_{i=1}^{N_s-1} \sum_{j=i+1}^{N_s} f_{ov}(F_i, F_j) + \sum_{i=1}^{N_s} \sum_{j=1}^{N_a} f_{ov}(F_i, A_j)$$

$$f_{ov}(R_1, R_2) = \omega(R_1 \cap R_2)h(R_1 \cap R_2)$$

b. Formula for non-overlap

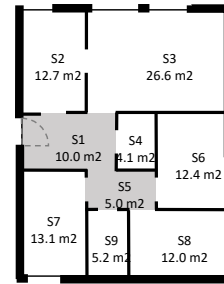

c. An example of generated layouts

FIG. 4.7 Generation process used in [24,25] (also the source of images)

4.3.2.3 Graph-theory aided method

In this method, space adjacencies are transformed to a planar graph, and algorithms for graph theory are used to convert the planar graph into a feasible space layout [51,52]. In this method, the generation process is clearly divided into topology and geometry design. Taking the study of [52] for example: first, the space adjacency preferences are stored in a 2D matrix, which can be varied for alternatives (Figure 4.8.a); then, the matrix is transformed to a planar graph, in which nodes represent spaces and links represent connections (Figure 4.8.b); algorithms are used to convert the planar graph to a graph which can be converted to a feasible layout, like a dual graph, in which the links can be divided into multi-floors (Figure 4.8.c); the final space layout is obtained by inserting geometric information to the graph (Figure 4.8.d). Regarding the last step, the geometric information was inserted by

designers or architects manually in the study of [52]. Extra steps are needed for the generation of geometric variants, in order to realise the automation for the whole generation process. For instance, in the study of [49], the location of space centre points was used as the starting point, and the middle line between two adjacent points was used as the edge of the rectangle space. After all middle lines were found, the initial floor plan with rectangle spaces was obtained. Then, by changing the locations of the centre point for each space, the width and length are changed correspondingly. In addition to the dual graph used in [51,52], other algorithms can also be used, like Voronoi diagram in [49].

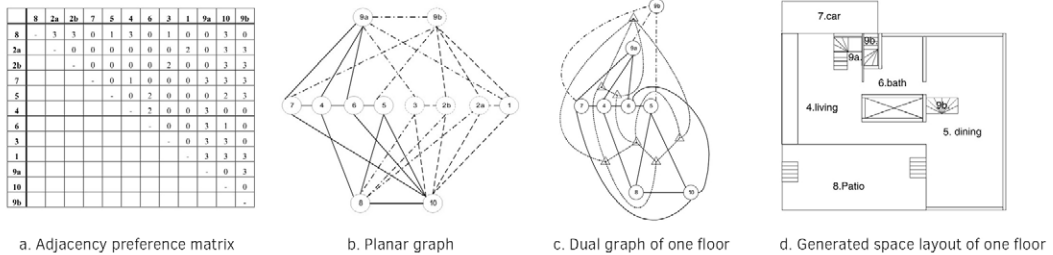

FIG. 4.8 Generation process used in [52] (also the source of images)

4.3.2.4 Cell assignment method

In this method, the building geometry is predefined and divided into 3D cells with the same size. The generation process is reformulated to a process to assign different spaces to the cells [10,23,55,63,64]. First, a matrix is defined by users to represent the cells in the building, and the value in the matrix represents which space is assigned to the corresponding cell (Figure 4.9.a); second, spaces are assigned to the cells in the building geometry correspondingly (Figure 4.9.b); then, by changing the values in the matrix, the feasible layout can be obtained satisfying both geometric and topological requirements (Figure 4.9.c). In addition to using a matrix, a method with a space-filling curve was also used in [18,65], in which spaces were assigned to cells according to the sequence defined in the curve.

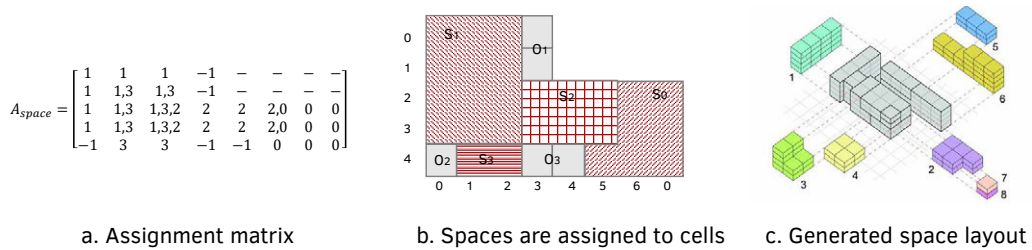

FIG. 4.9 Generation process in [23] (also the source of images)

4.3.2.5 Space splitting method

In this method, a predefined floor plan is split recursively following a sequence, which is stored in a data tree [56,57,66]. The node in the data tree represents a space, and the value in the node represents the dimensional information for where the splitting line locates, like the space area. First, a floor plan is defined by users (Figure 4.10.a); second, space dimensions and adjacencies are coded into a data tree (Figure 4.10.b), which can be varied for layout alternatives; third, the initial layout is recursively split based on the tree data (Figure 4.10.c); finally, the final layout is generated after all splits (Figure 4.10.d). There are different slicing methods as shown in [56], like slicing by distance, slicing by ratio, and slicing by area. Some splitting strategies can help to generate irregular spaces. For instance, the ice-ray shape grammar was used to generate polygonal spaces in [66], and predefined splitting lines from designers were used to split the layout in [50].

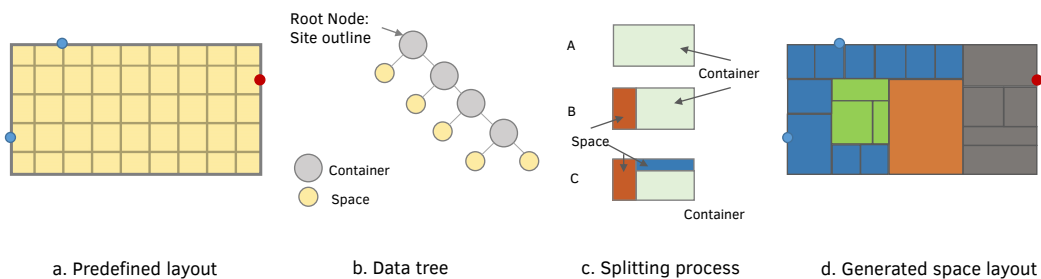

FIG. 4.10 Generation process in [56] (also the source of images)

4.3.2.6 Occupant-trace based method

In this method, a space layout is generated based on occupant tracks, which are obtained by simulating occupant movements [58]. First, occupant movements are simulated, which are controlled by external forces of attraction and repulsion, and affected by the environmental elements, like obstacles and destinations (Figure 4.11.a); second, the simulated occupant tracks are used as circulation paths (Figure 4.11.b); third, the circulation paths are meshed and converted to feasible spaces (Figure 4.11.c); finally, the left-over spaces are used as the volumes to accommodate functional spaces (Figure 4.11.d).

Several tools are available to simulate occupant movements, like Quelea in Grasshopper [67] and PEDSIM [68]. This method is broadly used for the site planning [69,70], and some studies used this method to evaluate the existing space layout for renovation [71,72]. A similar concept was applied to the interactive design of the interior space, in which the furniture changed accordingly to occupant movements resulting in different interior spaces [73].

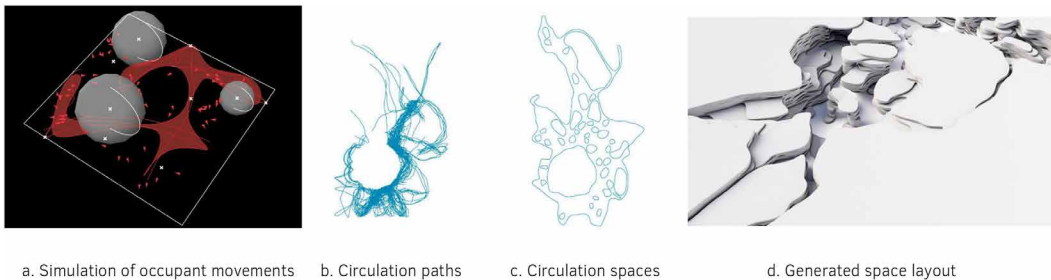

FIG. 4.11 Generation process in [58] (also the source of images)

4.3.2.7 Machine learning method

In this method, a model of machine learning is trained based on the dataset with real cases of space layouts, then the trained model is used to generate space layouts with certain inputs [59–61]. The machine learning method is a method to mimic the decision making process of architects based on their expertise and experience [60], without the need to understand thoroughly the logic behind the experience. Taking the study [59] for example, Generative Adversarial Network (GAN) was used for machine learning and the developed method is as follows. First, the real cases of space layouts are collected (Figure 4.12.a) and used as dataset. Second, the

collected space layouts are labelled manually using different colours to represent spaces, i.e. colour labelled map (Figure 4.12.b). Third, one network is trained using the colour labelled maps as input and space layouts as outputs.

After this, the model with the network is able to produce the space layouts based on labelled maps. Chaillou [61] furtherly developed this technique into an available tool that can be used by designers, and the design procedure with this tool is as follows: firstly, designers define the layout boundary, the entrance and windows; then the trained model is used to generate the coloured map and add furniture to the coloured map. Regarding the elements used as inputs of dataset, the study of [59] used images of space layouts as inputs, while a natural language description [74] and the features of space layouts (like space adjacency, room area, and layout area) [75] were also used. Additionally, the deep learning approach was also used for the generation of space layouts, which does not need to manually label space layouts for inputs, as shown in [60].



a. Example of the collected space layout

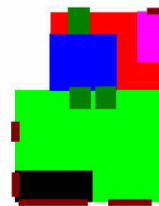

b. Corresponding colour labelled map

FIG. 4.12 Collected space layout and colour labelled map in [59] (also the source of images)

4.3.2.8 Classification of relevant studies

We classify the collected 66 studies based on our categorisation, in Table 4.5. Among these studies, some combined different GSL methods. The combination takes advantage of the strength of different methods, as some methods are easier to generate topological solutions, while others are easier to generate geometric solutions. For instance, Takizawa et al. [76] combined space splitting method and cell assignment method, in which a data tree was used to generate topological solutions and then spaces were assigned to cells accordingly; Guo and Li [45] combined physically based method and cell assignment method, in which physically forces were used for topological solutions and building geometry was optimised within cells.

TABLE 4.5 Classify studies into different GSL methods

GSL method	authors	Year	Ref.	GSL method	authors	Year	Ref.	
Physically based method	Guo & Li	2017	[45]	Mathematical programming method	Anderson et al.	2018	[77]	
	Christensen	2014	[78]		Lee & Ham	2018	[79]	
	Biagini et al.	2014	[80]		Nagy et al.	2017	[46]	
	Hsu & Krawczyk	2004	[81]		Song et al.	2016	[82]	
	Arvin & House	2002	[44]		Boonstra et al.	2016	[83]	
	Harada et al.	1995	[84]		Hempel et al.	2015	[32]	
	Fortin	1978	[85]		Koenig & Standfest	2014	[86]	
Graph-theory aided method	Ślusarczyk	2018	[87]		Suter et al.	2014	[88]	
	Wang et al.	2018	[89]		Rodrigues et al.	2013	[24]	
	Hua	2016	[50]		Suter	2013	[90]	
	Nourian et al.	2016	[51]		Regateiro et al.	2012	[91]	
	Shekhawat	2015	[53]		Manthilake	2011	[92]	
	Chatzikonstantinou	2014	[49]		Shikder et al.	2010	[93]	
	Lobos & Trebilcock	2014	[19]		Ülker & Landa-Silva	2010	[94]	
	Verma & Thakur	2010	[48]		Loemker	2006	[95]	
	Wong & Chan	2009	[52]		Baušys & Pankrašovaite	2005	[27]	
	Schwarz et al.	1994	[96]		Michalek et al.	2002	[28]	
	Roth & Hashimshony	1988	[97]		Medjoub & Yannou	2000	[47]	
Ruch	1978	[98]	Flemming & Chien		1995	[99]		
Cell assignment method	Guo & Li	2017	[45]		Space splitting method	Cao et al.	1990	[100]
	Blom et al.	2017	[101]			Elshafei	1977	[102]
	Boonstra et al.	2016	[83]	Das et al.		2016	[56]	
	Dino	2016	[23]	Koenig & Knecht		2014	[57]	
	Yi	2016	[10]	Takizawa et al.		2014	[76]	
	Herr & Ford	2016	[103]	Langenhan et al.		2013	[104]	
	Takizawa et al.	2014	[76]	Correia et al.		2012	[66]	
	Yi & Yi	2014	[18]	Knecht & Koenig		2010	[105]	
	Zawidzki et al.	2011	[106]	Yao et al.		2003	[107]	
	Lopes et al.	2010	[108]	Roth et al.		1982	[109]	
	Yeh	2006	[54]	Occupant-trace based method	Ghaffarian et al.	2018	[58]	
	Gero & Kazakov	1998	[55]		Dzeng et al.	2014	[71]	
	Sharpe	1973	[110]		Lee et al.	2012	[72]	
Machine learning method	Chaillou	2019	[61]					
	Huang & Zheng	2018	[59]					
	Peng & Zhang	2017	[111]					
	Jain et al.	2015	[74]					
	Merrell et al.	2010	[75]					

4.3.3 Evaluation of the 7 GSL methods

The 7 methods identified as current possible methods to generate layouts are evaluated on their pros and cons in this subsection, based on a set of criteria.

4.3.3.1 Criteria to evaluate GSL methods

Four criteria were used to evaluate GSL methods in [57]: performance, reliability, variance and interaction. These criteria are mainly used to evaluate the automation performance. Additionally, we adjust these criteria and add the requirements for space layout design. The criteria are explained as follows:

- **Feasibility:** whether the generated layouts are feasible or not, considering the requirements for practice.
- **User-friendliness:** whether the method is easy to be controlled by designers.
- **Generation speed:** how fast the method can generate layout solutions.
- **Variance:** how easy the method is used to generate variants.
- **Capability of multi-floor:** how easy the method is used to generate multi-floors. This is important, as in practice most buildings have multi-floors. This is also an issue for facility layout planning, as shown in [17].
- **Capability of irregularity:** whether the method can generate an irregular boundary or space, except for rectangle. The more space forms the method can create, the more options designers can have.
- **Necessity of predefined boundary:** whether the method needs a predefined boundary or not. In practice, the boundary design might happen before or after space layout design, and it can also be the result of interior space layout design. This requires that the GSL method is capable to use a layout boundary predefined by designers, as well as to generate the layout boundary by itself.

4.3.3.2 Evaluation

The 7 criteria are divided into the ones that can be quantified and the ones that can only be qualified. The **quantifiable** criteria include generation speed, variance, capability of multi-floor, capability of irregularity, and necessity of predefined boundary. The **qualitative** criteria include feasibility and user-friendliness, and they are the properties that future studies should satisfy. Regarding **feasibility**, the generated layout should be feasible for practice, considering structure, fire evacuation, construction, and financial cost, etc. Regarding **user-friendliness**, the representation elements used for the developed method should be suitable for the targeted users. For instance, architects might prefer to use the graphic language, while programmers and engineers might prefer to use numbers.

The quantifiable criteria, except for the generation speed, are compared between the categorised 7 GSL methods in Table 4.6. Different values are given to different methods according to their strength of each property, marked with '+', except for 'necessity of predefined boundary' and 'change boundary' for variance. The generation speed cannot be compared, as the layouts in different studies have diverse numbers of spaces.

TABLE 4.6 Compare the properties of GSL methods

	Variance			Multi-floor	Capability of Irregularity	Predefined boundary
	Change boundary	Change topology	Change geometry			
Physically based method	Yes	+++	+	+	+	No
Mathematical programming method	Yes	+	+++	++	++	No
Graph-theory aided method	Yes	+++	+	++	++	No
Cell assignment method	No	++	++	+++	+++	Yes
Space splitting method	No	+++	+	++	++	Yes
Occupant-trace based method	No	/	/	++	+++	Yes
Machine learning method	Yes	/	/	+++	+++	No

Note:

'/' means that the property cannot be compared. The number of '+' is given based on the method's strength of each property. 'Change boundary' means whether the layout boundary can be changed or not; 'change topology' and 'change geometry' mean the ability of the GSL method to change the topology and geometry of space layouts respectively.

Variance

The variance cannot be compared based on the total quantity of generated variants in the relevant studies, as they did not show the exact number of variants. The variance can be compared in terms of whether the layout boundary can be changed or not, the ability to change the topology of space layouts, and the ability to change the geometry of space layouts. If the method can change the layout boundary, the variants include the ones with changed boundaries. The process of space layout design with most GSL methods can be divided into the satisfaction of requirements for both topology and geometry. There is a trade-off between the ability to change topology and geometry. For instance, the mathematical programming method is much easier to change geometry with the change of coordination, while extra operators are needed if the topology want to be changed effectively, like rotating, stretching, and mirroring [24]. The graph-theory aided method is much easier to change the topology by changing the index in the adjacency matrix, while in order to change the geometry, extra efforts are needed as explained in Subsection 4.3.2.3. The cell assignment method is moderate compared to other methods, as the change of index in the assignment matrix with this method causes the change of space adjacencies as well as the dimension of spaces. Occupancy-trace based method and machine learning method cannot be evaluated for ‘change typology’ and ‘change geometry’, as they have different generation process from other methods.

Capability of multi-floor

The capability of multi-floor is compared regarding how easy the method is used to generate multi-floors. So far, most methods have been usable to generate multi-floor layouts [48,49,52,61,112,113], except for the physically based method. But this method can generate multi-floor layouts by combining with other methods, like in [45]. As for the cell assignment method, as long as the predefined cells are multi-floor as well as the corresponding assignment matrix, the generated layout is multi-floor. As for machine learning method, the same model of machine learning can be used to generate the layouts for different floors. Besides, one can envision that as long as the layouts used as the dataset are multi-floor, the generated layouts can be multi-floor. In contrast, the other methods need designers to pre-assign different spaces to different floors.

Capability of irregularity

The capability of irregularity is purely decided based on the form of generated spaces, as the boundary form can be predefined by designers or it can be the results of combined spaces. The occupant-trace based method generates an organic form which has the highest irregularity [58]. The cell assignment method is easy to generate polygonal spaces with combined cells [10,23,55]. The machine learning method has shown a high capability to generate irregular space forms, as shown in [61], and the space form of generated space layouts is decided based on the space form in the training dataset. However, although some other studies can also generate polygonal spaces, they used the combined method, like mathematical programming method and space splitting method in [46], and graph-theory based method and cell-assignment method in [50]. No study with physically based method is found to generate polygonal spaces.

Necessity of predefined boundary

A predefined boundary is necessary for cell-assignment method, space splitting method, and occupant-trace based method, while it is not necessary for the others.

4.3.4 Optimisation of GSL for layout functionality

We collect the actions taken to change design variables for optimisation, objectives and constraints, and optimisation algorithms of the 22 studies in Table 4.3. While optimisation algorithms are not discussed as they are not the focus of this paper, the other factors are analysed as follows. Regarding design variables, among the elements used to represent space layouts, only several are used as design variables for optimisation. Especially in graph-theory aided method and space splitting method, only topological design variables are changed, like space indexes in an adjacency matrix and a data tree. Regarding the actions taken to change design variables for optimisation, actions vary with different methods, adaptive to the used design variables. For instance, physically based method changes the force strength, and mathematical programming method alters space coordinates, and graph-theory aided method and cell assignment method vary the space index in the adjacency matrix, and space splitting method adjusts the values in the data tree. Regarding the constraints and objectives, in addition to the ones listed in Table 4.4, others objectives are also used, like minimal cost [49], minimal evacuation time [48], and maximal view to outside [46]. Besides, some objectives are relevant to the specific building function, like the minimal nurse travel distance in hospital design [56].

4.4 Requirements for EPO regarding the combination with GSL

EPO includes two parts: EP and optimisation, as shown in Figure 4.2. Regarding EP, we detect the requirements for energy indicators and the modelling method for energy performance assessment. Regarding the optimisation part, we analyse the design variables for energy performance optimisation and categorise the methods to reduce computational time.

4.4.1 Requirements for energy performance assessment

In order to be successfully combined with energy assessments, an GSL method should be useable to calculate a set of meaningful indicators for energy performance and it should allow an appropriate subdivision of the layout into individual thermal zones.

4.4.1.1 Energy indicators for assessment

Energy performance includes different aspects, i.e. heating, cooling, lighting, and ventilation. In order to fully assess the capability of G-EPO to improve the whole energy performance, all aspects of energy performance (heating, cooling, lighting and ventilation) should be detected. Regarding the assessment boundary, energy indicators can be divided into energy demand, final energy, and primary energy: energy demand is assessed within conditioned building zones, which is calculated based on energy balance; final energy is assessed within the building site, which adds the energy losses from energy distribution systems; primary energy is assessed outside the building site, which adds the energy losses from energy production. The used assessment boundary should be clearly stated in future research. Additionally, only if daylighting and natural ventilation are considered in energy performance assessment, the effect of space layouts on energy performance can be fully identified. So the integration of daylighting and natural ventilation with energy simulation is necessary in energy performance assessment.

4.4.1.2 Individual zoning method

The simplified steady-state calculation method for energy performance does not need a 3D model as shown in [27,28,30], while the dynamic simulation method needs the 3D thermal zone based model. The modelling process for the dynamic simulation is as follows: first, the model (mostly 2D) obtained from the generation of space layouts is developed into a 3D model by adding height to spaces; then the 3D model is divided into different thermal zones; third, the other information of the building (like HVAC system, internal gains, and materials) is added to the model; finally the dynamic simulation is run with the model.

Different methods of thermal zoning have been used, as shown in [7]: most studies modelled the whole layout as one zone (Figure 4.13.a), or separated it into 4 perimeter zones and one core (Figure 4.13.b), while some studies separated spaces into individual zones or clustered similar spaces into one zone (Figure 4.13.c). The last method is called individual zoning in this paper, and a similar zoning method was proposed in [114]. The first two methods ignore the individual requirements of different spaces and have lower accuracy. Different spaces have various requirements for thermal and visual comfort, as the occupant's activities are different. For instance, as recommended by NEN 16798-1 [115], the heating set-point of offices is 20-25 °C, while the value of corridors is 16-25 °C. By satisfying the individual requirements of different spaces, the whole building energy performance will be drastically decreased, compared to using the same requirements for all spaces. In order to simulate the individual requirements of spaces, the individual zoning method is required.

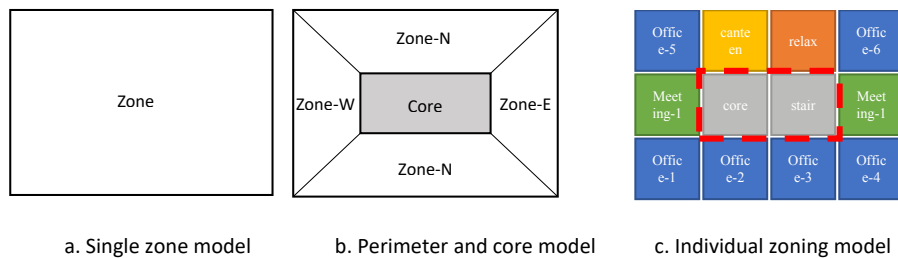

FIG. 4.13 Three different zoning methods, adapted from [116]

4.4.2 Requirements for energy performance optimisation

In order to be successfully combined with the computational parametric optimisation for energy performance, an GSL method should be usable to generate different layout alternatives based on the design variables meaningful for energy performance optimisation. Moreover, EPO should allow a rather fast process to avoid excessive computational time.

4.4.2.1 Design variables

Computational parametric optimisation is based on the generation and performance assessment of design alternatives. The design alternatives differ from each other based on design variables. When focusing on the energy performance assessment of layouts, the design variables that can affect energy performance depending on the energy balance equation are concluded and classified depending on their relevance with space layout design in Table 4.7 [117].

TABLE 4.7 Design variables for energy performance optimisation, relating to space layout design

Design variables of space layouts (with a non-fixed boundary)		Space properties		Envelope design
Space layout design (within a fixed boundary)		Functional requirements	Use of spaces	
<ul style="list-style-type: none"> – Function allocation – Space dimension – Space form – Interior partitioning 	<ul style="list-style-type: none"> – Boundary dimension – Boundary form – Orientation 	<ul style="list-style-type: none"> – Set-point temperature for heating – Set-point temperature for cooling – Lighting requirements (e.g. illuminance) – Ventilation requirement (e.g. air flow rate) – Control types 	<ul style="list-style-type: none"> – Occupancy, activity and schedule – Internal gains from appliances and lighting – Opening state of windows and interior doors 	<ul style="list-style-type: none"> – Thermal transmittance – Window area – Window location – Glazing type – Shading type and effectiveness – Air tightness

Note: 'Function allocation' means allocating different functions to different rooms. 'Control types' means the different types of the control for lighting, ventilation, heating and cooling systems. 'Appliances' include the used devices, equipment and machines.

The design variables belonging to space layout design can be divided into the design variables within a fixed boundary [5,10,23,28] and the ones within a non-fixed boundary [11,106]. Space properties change with the change of space functions [118–120]. These space properties include: functional requirements, like the set-points for heating, cooling, lighting and ventilation, as well as control types; use of spaces, like the profiles of internal gains resulting from occupancy, appliances and lighting. The envelope design of the building is important for building energy performance, which can influence the impact of space layouts on energy performance [118].

4.4.2.2 Reduce computational time

The building optimisation with multi-objectives is always a time-consuming process. According to Attia et al. [3], the computational time is one of the most important obstacles to the development of energy performance optimisation. Additionally, the energy performance assessment model of space layouts becomes rather complex with individual zoning, which would need more computational time. On the other hand, the detailed dynamic simulation is necessary to obtain the accurate results of energy performance, which makes the energy performance assessment more time consuming. We identify 5 methods to reduce the computational time regarding the elements in energy performance assessment, among which two methods have been used for EPO, i.e. offline simulation [31] and hierarchical structuring of design variables [26].

Offline simulation

The offline simulation method is to conduct all required simulations before optimisation, in which the rooms with similar situations share the same simulation results. For instance, the rooms facing the same direction share the same daylight illuminance results. In this way, the same simulations do not need to be run for each solution during the optimisation process. The studies using the offline simulation method have shown to be less time consuming [31,121].

Replacing simulation models with surrogate models

In this method, surrogate models are used to emulate detailed simulation models. The process of surrogate model derivation includes the following steps [122]: first, define the design parameters (inputs) and design objectives (outputs) for the surrogate model; second, create a base building model to generate samples; third, run samples to build database; fourth, fit the surrogate model to the database; fifth, validate the surrogate model for accuracy. The surrogate model is used to predict outcomes instantly based on the given building information, thus saving much computational time which researchers or designers used to spent on simulations [122]. Surrogate models have been used in different stages of building design, i.e. conceptual design stage [123], sensitivity analysis [124], uncertainty analysis [125], and optimisation [126]. Regarding the design parameters used as inputs, variables of building geometry, windows, and material properties are mainly used [122]. The consumed time is significantly reduced using the surrogate model in comparison to the simulation-based method [127]. For instance, in [128], a surrogate based optimisation method was developed combining ANN and genetic algorithm to help retrofit existing buildings. The results of a case study for a school building show that the total computational time needed for the whole optimisation process involving the training and validation of the ANN model is 3 days. In comparison, the computational time that a simulation-based optimisation would be 75 days.

Sequentially using different assessment methods

There are various methods for energy performance assessment, varying from a simple steady-state calculation to a complex dynamic simulation. Their prediction accuracy and computational time are different. Generally, the computational time is proportional to the prediction accuracy. Correspondingly, optimisation is an iteration process evolving from the preliminary search to the accurate identification of the optimal solution. Invoking the assessment methods from simple to complex in the sequence of optimisation phases can save much time while keeping similar accuracy, compared to only using complex assessment methods. The study of [129] sequentially used simple yearly calculation, linearized convection calculation, and dynamic simulation following the different phases of optimisation. The results in this study show that the optimisation process using this sequential assessment method saves 2.5 days compared to the method solely using EnergyPlus, which reaches the similar minimum heating and cooling demands.

Hierarchical structuring of design variables

There are plenty of design variables in building design, and some variables change dependently on others. Structuring hierarchical layers of design variables can avoid infeasible solutions, thus saving the unnecessary computational time, as shown in [130]. The design variables of space layouts are mutually dependent, as shown in Table 4.7. For instance, the geometry design can be the result of space layout design. Space uses are affected by space layout design. For instance, an open office has a higher occupancy density than a cell office. Thus, structuring hierarchical layers of layout variables can help to avoid infeasible layouts in the generation process. Besides, sequentially invoking different design variables in optimisation process, based on their importance for energy performance, can also help to save computational time, like in Rodrigues et al. [26].

Hierarchical structuring of optimisation objectives

Similar to design variables, optimisation objectives can also be structured into hierarchical layers. In the study of [131], a target-cascading optimisation method was developed, in which the optimisation objectives were structured into overall performance (overall area and thermal efficiency), thermal comfort, and energy loads. Once the current layer of objectives was satisfied, design variables were passed to the next layer for the optimisation of sub-targets. Regarding EPO, the optimisation objectives can be structured based on space layouts' impact on these objectives. For instance, the study of [116] shows that changing space layouts affects the lighting demand the highest, compared to heating and cooling demands. In this case, the lighting demand can be on the top layer in the objective hierarchy.

4.5 Conclusions, summaries and recommendations

4.5.1 Conclusions

In this paper, we collect and review the studies focusing on G-EPO. The review result shows that G-EPO is a promising topic for research and also for architectural design, especially for energy-efficient design. The collected references show promising results, as building energy performance is significantly improved comparing the optimised design with the original design, and the generated layouts are practical and various. Based on this, we extend the analysis to two relevant research domains, i.e. G-O and EPO, in order to find their respective requirements considering their combination. Regarding G-O, 7 GSL methods are categorised based on 66 collected papers. They are evaluated in terms of automation performance and the requirements for space layout design. The requirements for its combination with optimisation are also investigated. Regarding EPO, the requirements for energy performance assessment of space layouts are identified, in terms of energy indicators and zoning method. The design variables for energy performance optimisation are inspected, as well as the methods to reduce computational time.

4.5.2 Summaries

We summarise the review regarding G-O and EPO.

4.5.2.1 G-O phase

Regarding the G-O phase, 7 classified GSL methods are compared regarding their generation speed, feasibility, variance, user-friendliness, capability of multi-floor, capability of irregularity, necessity of predefined boundary. The quantifiable criteria are evaluated and compared between methods in Table 4.6, which would help designers choose the proper generation method. For instance, if designers have a preference for variance, the mathematical programming method is superior to other methods; if designers prefer to easily generate multi-floors, the cell assignment method is superior to others.

4.5.2.2 EPO phase

EPO phase includes energy performance assessment and optimisation. Future research should calculate the different energy indicators (for heating, cooling, lighting and ventilation) as more as possible, as there is a trade-off between different energy indicators. The used assessment boundary should be clearly stated, differing between energy demand, final energy, and primary energy. The integration of daylighting and natural ventilation with energy simulation is also highly recommended for the calculation of energy performance. Regarding the zoning method, the individual zoning method should be used in future research for higher accuracy and modelling the different properties of different spaces. Different properties should be modelled in the assessment model of energy performance for different spaces, like set-points for heating, cooling, lighting and ventilation, occupancy, and internal loads.

Regarding the optimisation part, future research should develop an effective way to reduce computational time, since it is the predominant obstacle to energy performance optimisation. We identify 5 methods to reduce the computational time. The method of offline simulation needs predefined space layout typologies and massive beforehand simulations, and it is not flexible enough to explore layout variants, but suitable to the designs for a given building type which has specific layout typologies. The method with surrogate models would be an effective way to

save computational time for space layouts. It is recommended to test the feasibility of surrogate models for the assessment of energy performance of space layouts. However, as discussed before, space layouts cannot be easily represented in parametric variations, so the choice of design parameters (inputs) and the creation of samples are crucial. The hierarchical methods of design variables, optimisation objectives, and simulation methods do not need predefined layouts. They are more practical and suitable for small-scale design projects.

4.5.3 Recommendations

We formulate some recommendations regarding the whole process of G-EPO, which would help future research. Generally, there is a trade-off between G-O and EPO. The automatic generation of space layouts is developed from the perspective of designers and its outcomes need high variance and diversity, which requires a fast feedback from EPO. In contrast, in order to have a high accuracy of energy performance, EPO needs detailed models, which is time consuming. Regarding the integration of G-O and EPO, the computational time is the main concern, as well as the compatibility of the used tools with both G-O and EPO. As for the future research, two main methodologies of G-EPO are proposed as follows:

- the current method as shown in Figure 4.3 and 4.4 with a fast decision process, either with a simplified method (or surrogate model) for energy performance assessment or using a powerful machine to run the process.
- an alternative method (Figure 4.14): first, building the parametric optimisation model for energy performance and running optimisation; then, learning the relationship between design variables of space layouts and energy performance manually or with a machine learning method; finally, integrating the learnt relationship with one of the GSL methods, and the generated layouts are expected to be energy-efficient.

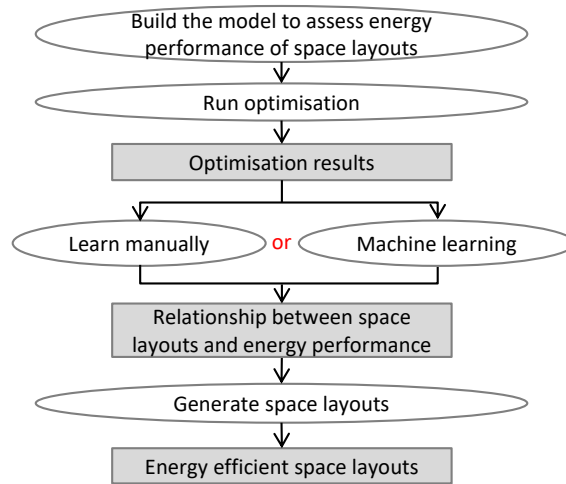

FIG. 4.14 Proposed alternative methodology for G-EPO

The G-EPO aims to develop the available methodology or tool that can be used by architects and engineers, and release them from the redundant and repeatable work with the computational method. For now, this research area lacks the inputs of the requirements from the possible users, like architects and engineers. It would be helpful to conduct a survey to the possible users for their expectations of G-EPO, for instance, as for architects, the inputs that they prefer to use and the workflow that they would like to follow for space layout design, as for engineers, the outcomes that they expect to obtain from the energy performance optimisation of space layouts.

References

- [1] X. Cao, X. Dai, J. Liu, Building energy-consumption status worldwide and the state-of-the-art technologies for zero-energy buildings during the past decade, *Energy and Buildings*. 128 (2016) 198–213. <https://doi.org/10.1016/j.enbuild.2016.06.089>.
- [2] B. Ekici, C. Cubukcuoglu, M. Turrin, I.S. Sariyildiz, Performative computational architecture using swarm and evolutionary optimisation: A review, *Building and Environment*. 147 (2019) 356–371. <https://doi.org/10.1016/j.buildenv.2018.10.023>.
- [3] S. Attia, M. Hamdy, W. O'Brien, S. Carlucci, Assessing gaps and needs for integrating building performance optimization tools in net zero energy buildings design, *Energy and Buildings*. 60 (2013) 110–124. <https://doi.org/10.1016/j.enbuild.2013.01.016>.
- [4] Design to Construction | AIA ETN. <https://www.aiaetn.org/find-an-architect/design-to-construction/>. Accessed: January 2020.
- [5] F. Musau, K. Steemers, Space Planning and Energy Efficiency in Office Buildings: The Role of Spatial and Temporal Diversity, *Architectural Science Review*. 51 (2008) 133–145. <https://doi.org/10.3763/asre.2008.5117>.
- [6] F. Musau, K. Steemers, Space Planning, Ventilation and Energy Efficiency in Offices, *International Journal of Ventilation*. 8 (2009) 9–22. <https://doi.org/10.1080/14733315.2006.11683828>.
- [7] C.B. de Souza, S. Alsaadani, Thermal zoning in speculative office buildings: discussing the connections between space layout and inside temperature control, in: *Proceedings of the 1st Building Simulation and Optimization Conference*, Loughborough, UK, 2012: pp. 417–424. <http://www.ibpsa.org/proceedings/BSO2012/6C1.pdf>. Accessed: April 2017.
- [8] H. Poirazis, Å. Blomsterberg, M. Wall, Energy simulations for glazed office buildings in Sweden, *Energy and Buildings*. 40 (2008) 1161–1170. <https://doi.org/10.1016/j.enbuild.2007.10.011>.
- [9] I.G. Dino, G. Üçoluk, Multiobjective Design Optimization of Building Space Layout, Energy, and Daylighting Performance, *Journal of Computing in Civil Engineering*. 31 (2017) 04017025. [https://doi.org/10.1061/\(ASCE\)CP.1943-5487.0000669](https://doi.org/10.1061/(ASCE)CP.1943-5487.0000669).
- [10] H. Yi, User-driven automation for optimal thermal-zone layout during space programming phases, *Architectural Science Review*. 59 (2016) 279–306. <https://doi.org/10.1080/00038628.2015.1021747>.
- [11] E. Rodrigues, A.R. Gaspar, Á. Gomes, Automated approach for design generation and thermal assessment of alternative floor plans, *Energy and Buildings*. 81 (2014) 170–181. <https://doi.org/10.1016/j.enbuild.2014.06.016>.
- [12] R. Evins, A review of computational optimisation methods applied to sustainable building design, *Renewable and Sustainable Energy Reviews*. 22 (2013) 230–245. <https://doi.org/10.1016/j.rser.2013.02.004>.
- [13] C.A. Conceicao Antonio, J.B. Monteiro, C.F. Afonso, Optimal topology of urban buildings for maximization of annual solar irradiation availability using a genetic algorithm, *Applied Thermal Engineering*. 73 (2014) 422–435. <https://doi.org/10.1016/j.applthermaleng.2014.08.007>.
- [14] A. Karatas, K. El-Rayes, Optimizing tradeoffs among housing sustainability objectives, *Automation in Construction*. 53 (2013) 83–94. <https://doi.org/10.1016/j.autcon.2015.02.010>.
- [15] A. Drira, H. Pierrel, S. Hajri-Gabouj, Facility layout problems: A survey, *Annual Reviews in Control*. 31 (2007) 255–267. <https://doi.org/10.1016/j.arcontrol.2007.04.001>.
- [16] R.S. Liggett, Automated facilities layout: Past, present and future, *Automation in Construction*. 9 (2000) 197–215. [https://doi.org/10.1016/S0926-5805\(99\)00005-9](https://doi.org/10.1016/S0926-5805(99)00005-9).
- [17] A. Ahmadi, M.S. Pishvae, M.R. Akbari Jokar, A survey on multi-floor facility layout problems, *Computers and Industrial Engineering*. 107 (2017) 158–170. <https://doi.org/10.1016/j.cie.2017.03.015>.
- [18] H. Yi, Y.K. Yi, Performance based architectural design optimization: automated 3d space layout using simulated annealing, in: *Proceedings of ASHRAE/IBPSA—Building Simulation Conference*, Atlanta, GA, USA, 2014: pp. 292–299. <https://experts.illinois.edu/en/publications/performance-based-architectural-design-optimization-automated-3d->.
- [19] D. Lobos, M. Trebilcock, Building performance information and graphs approach for the design of floor plans, *Arquiteturarevista*. 10 (2014) 23–30. <https://doi.org/10.4013/arq.2014.101.03>.
- [20] P. McKeen, A. Fung, The Effect of Building Aspect Ratio on Energy Efficiency: A Case Study for Multi-Unit Residential Buildings in Canada, *Buildings*. 4 (2014) 336–354. <https://doi.org/10.3390/buildings4030336>.

- [21] S. Boonstra, K. van der Blom, H. Hofmeyer, M.T.M. Emmerich, J. van Schijndel, P. de Wilde, Toolbox for super-structured and super-structure free multi-disciplinary building spatial design optimisation, *Advanced Engineering Informatics*. 36 (2018) 86–100. <https://doi.org/10.1016/j.aei.2018.01.003>.
- [22] Y. Schwartz, R. Raslan, I. Korolija, D. Mumovic, Integrated Building Performance Optimisation: Coupling Parametric Thermal Simulation Optimisation and Generative Spatial Design Programming Introduction and Aims, in: *Proceedings of the 15th International Building Performance Simulation Association*, San Francisco, 2017: pp. 1222–1229. <https://doi.org/10.26868/25222708.2017.316>.
- [23] I.G. Dino, An evolutionary approach for 3D architectural space layout design exploration, *Automation in Construction*. 69 (2016) 131–150. <https://doi.org/10.1016/j.autcon.2016.05.020>.
- [24] E. Rodrigues, A.R. Gaspar, Á. Gomes, An evolutionary strategy enhanced with a local search technique for the space allocation problem in architecture, Part 1: Methodology, *Computer-Aided Design*. 45 (2013) 887–897. <https://doi.org/10.1016/j.cad.2013.01.001>.
- [25] E. Rodrigues, A.R. Gaspar, Á. Gomes, An evolutionary strategy enhanced with a local search technique for the space allocation problem in architecture, Part 2: Validation and performance tests, *Computer-Aided Design*. 45 (2013) 898–910. <https://doi.org/10.1016/j.cad.2013.01.003>.
- [26] E. Rodrigues, A.R. Gaspar, Á. Gomes, Improving thermal performance of automatically generated floor plans using a geometric variable sequential optimization procedure, *Applied Energy*. 132 (2014) 200–215. <https://doi.org/10.1016/j.apenergy.2014.06.068>.
- [27] R. Baušys, I. Pankrašovaite, Optimization of architectural layout by the improved genetic algorithm, *Civil Engineering and Management*. 13 (2005) 37–41. <https://doi.org/10.1080/13923730.2005.9636328>.
- [28] J. Michalek, R. Choudary, P. Papalambros, Architectural layout design optimization, *Engineering Optimization*. 34 (2002) 37–41. <https://doi.org/10.1080/03052150214016>.
- [29] L. Caldas, Generation of energy-efficient architecture solutions applying GENE_ARCH: An evolution-based generative design system, *Advanced Engineering Informatics*. 22 (2008) 59–70. <https://doi.org/10.1016/j.aei.2007.08.012>.
- [30] H.A. Sleiman, S. Hempel, R. Traversari, S. Bruinenberg, An assisted workflow for the early design of nearly zero emission healthcare buildings, *Energies*. 10 (2017) 993. <https://doi.org/10.3390/en10070993>.
- [31] Z. Su, W. Yan, A fast genetic algorithm for solving architectural design optimization problems, *Artificial Intelligence for Engineering Design, Analysis and Manufacturing*. 29 (2015) 457–469. <https://doi.org/10.1017/S089006041500044X>.
- [32] S. Hempel, J. Benner, K.-H. Hafele, Generating Early Design Alternatives Based on Formalized Requirements and Geospatial Data, in: *Proceedings of the 32nd CIB W78 Conference*, Eindhoven, the Netherlands, 2015: pp. 255–264. <http://itc.scix.net/pdfs/w78-2015-paper-026.pdf>. Accessed: June 2018.
- [33] JEPlus-An EnergyPlus simulation manager for parameters. <http://www.jeplus.org/wiki/doku.php?id=start>. Accessed: October 2019.
- [34] J. Niemasz, DIVA for Rhino. <http://diva4rhino.com/>. Accessed: November 2019.
- [35] P.H. Levin, Use of Graphs to Decide the Optimal Layout of Buildings, *Architect*. 14 (1964) 809–815. <https://discovery.nationalarchives.gov.uk/details/r/C10976838>. Accessed: July 2017.
- [36] L. Helme, C. Derix, Spatial configuration: Semi-automatic methods for layout generation in practice, *The Journal of Space Syntax*. 5 (2014) 35–49. <http://128.40.150.106/joss/index.php/joss/article/view/201/pdf>. Accessed: June 2019.
- [37] K. Dutta, S. Sarthak, Architectural space planning using evolutionary computing approaches: A review, *Artificial Intelligence Review*. 36 (2011) 311–321. <https://doi.org/10.1007/s10462-011-9217-y>.
- [38] K. Nassar, New advances in the automated architectural space plan layout problem, in: *Proceedings of the International Conference on Computing in Civil and Building Engineering*, Nottinham, the UK, 2010: p. 6. <https://pdfs.semanticscholar.org/5ebe/2e80f6e0c94df293ad95f33ea00622aece0a.pdf>.
- [39] R.S. Frew, A Survey of Space Allocation Algorithms in Use in Architectural Design in the Past Twenty Years, in: *Proceedings of the 17th Design Automation Conference*, IEEE, Minneapolis, MN, USA, 1980: pp. 165–174. <https://doi.org/10.1109/DAC.1980.1585243>.
- [40] Y.C. Hsu, R.J. Krawczyk, New generation of computer aided design in space planning methods: A survey and a proposal, in: *Proceedings of the 8th International Conference on Computer Aided Architectural Design Research in Asia*, Bangkok, Thailand, 2003: pp. 101–115. http://papers.cumincad.org/cgi-bin/works/paper/caadria2003_b1-3. Accessed: December 2017.
- [41] D. Lobos, D. Donath, The problem of space layout in architecture: A survey and reflections, *Arquitetura Revista*. 6 (2010) 136–161. <https://doi.org/10.4013/arq.2010.62.05>.

- [42] V. Calixto, G. Celani, A literature review for space planning optimization using an evolutionary algorithm approach: 1992-2014, in: Proceedings of the 19th Conference of the Iberoamerican Society of Digital Graphics, Florianópolis, SC, Brasil, 2015: pp. 662–671. <https://doi.org/10.5151/desprosigradi2015-110166>.
- [43] T. Du, M. Turrin, S. Jansen, A. Van Den Dobbelen, N. Bioria, A Review on Automatic Generation of Architectural Space Layouts with Energy Performance Optimization, in: Proceedings of the 4th International Conference On Building Energy, Environment, Melbourne, Australia, 2018: pp. 856–861. <http://www.cobee2018.net/assets/pdf/p/283.pdf>. Accessed: June 2018.
- [44] S.A. Arvin, D.H. House, Modeling architectural design objectives in physically based space planning, *Automation in Construction*. 11 (2002) 213–225. [https://doi.org/10.1016/S0926-5805\(00\)00099-6](https://doi.org/10.1016/S0926-5805(00)00099-6).
- [45] Z. Guo, B. Li, Evolutionary approach for spatial architecture layout design enhanced by an agent-based topology finding system, *Frontiers of Architectural Research*. 6 (2017) 53–62. <https://doi.org/10.1016/j.foar.2016.11.003>.
- [46] D. Nagy, D. Lau, J. Locke, J. Stoddart, L. Villaggi, R. Wang, D. Zhao, D. Benjamin, Project Discover : An application of generative design for architectural space planning, in: Proceedings of the 17th Symposium on Simulation for Architecture and Urban Design, Toronto, Canada, 2017: pp. 59–66. <https://dl.acm.org/doi/10.5555/3289787.3289794>.
- [47] B. Medjdoub, B. Yannou, Separating topology and geometry in space planning, *Computer-Aided Design*. 32 (2000) 39–61. [https://doi.org/10.1016/S0010-4485\(99\)00084-6](https://doi.org/10.1016/S0010-4485(99)00084-6).
- [48] M. Verma, M.K. Thakur, Architectural space planning using Genetic Algorithms, in: Proceedings of the 2nd International Conference on Computer and Automation Engineering (ICCAE), IEEE, Singapore, 2010: pp. 268–275. <https://doi.org/10.1109/ICCAE.2010.5451497>.
- [49] I. Chatzikonstantinou, A 3-Dimensional Architectural Layout Generation Procedure for Optimization Applications: DC-RVD, in: Proceedings of the 2014 ECAADe Conference, Northumbria, UK, 2014: pp. 287–296. http://cumincad.scix.net/cgi-bin/works/Show?_id=ecaade2014_163&sort=DEFAULT&search=ioannis&hits=7.
- [50] H. Hua, Irregular architectural layout synthesis with graphical inputs, *Automation in Construction*. 72 (2016) 388–396. <https://doi.org/10.1016/j.autcon.2016.09.009>.
- [51] P. Nourian, S. Rezvani, S. Sariyildiz, A SYNTACTIC ARCHITECTURAL DESIGN METHODOLOGY : Integrating real-time space syntax analysis in a configurative architectural design process, in: Proceedings of the 9th International Space Syntax Symposium, Seoul, South Korea, 2013: pp. 048:1-048:15. <http://resolver.tudelft.nl/uuid:6edc5ae1-bfa4-4542-86e8-013e4edcfa0d>.
- [52] S.S.Y. Wong, K.C.C. Chan, EvoArch: An evolutionary algorithm for architectural layout design, *Computer-Aided Design*. 41 (2009) 649–667. <https://doi.org/10.1016/j.cad.2009.04.005>.
- [53] K. Shekhawat, Automated space allocation using mathematical techniques, *Ain Shams Engineering Journal*. 6 (2015) 795–802. <https://doi.org/10.1016/j.asej.2015.02.008>.
- [54] I.C. Yeh, Architectural layout optimization using annealed neural network, *Automation in Construction*. 15 (2006) 531–539. <https://doi.org/10.1016/j.autcon.2005.07.002>.
- [55] J.S. Gero, V.A. Kazakov, Evolving design genes in sapce layout planning problems, *Artificial Intelligence in Engineering*. 12 (1998) 163–176. [https://doi.org/https://doi.org/10.1016/S0954-1810\(97\)00022-8](https://doi.org/https://doi.org/10.1016/S0954-1810(97)00022-8).
- [56] S. Das, C. Day, A. Hauck, J. Haymaker, D. Davis, Space Plan Generator: Rapid Generation & Evaluation of Floor Plan Design Options to Inform Decision Making, in: Proceedings of the 36th Annual Conference of the Association for Computer Aided Design in Architecture, Ann Arbor, 2016: pp. 106–115. http://papers.cumincad.org/cgi-bin/works/Show?acadia16_106.
- [57] R. Koenig, K. Knecht, Comparing two evolutionary algorithm based methods for layout generation: Dense packing versus subdivision, *Artificial Intelligence for Engineering Design, Analysis and Manufacturing: AIEDAM*. 28 (2014) 285–299. <https://doi.org/10.1017/S0890060414000237>.
- [58] M. Ghaffarian, R. Fallah, C. Jacob, Organic Architectural Spatial Design Driven by Agent-Based Crowd Simulation, in: Proceedings of the 18th Symposium on Simulation for Architecture and Urban Design, San Diego, CA, United States, 2018: pp. 173–180. <https://doi.org/https://dl.acm.org/doi/10.5555/3289750.3289767>.
- [59] W. Huang, H. Zheng, Architectural drawings recognition and generation through machine learning, in: Proceedings of the 38th Annual Conference of the Association for Computer Aided Design in Architecture, Mexico City, 2018: pp. 156–165. http://cumincad.scix.net/data/works/att/acadia18_156.pdf.

- [60] D. Sharma, N. Gupta, C. Chattopadhyay, S. Mehta, DANIEL: A Deep Architecture for Automatic Analysis and Retrieval of Building Floor Plans, in: Proceedings of the 14th IAPR International Conference on Document Analysis and Recognition, Kyoto, Japan, 2017: pp. 420–425. <https://doi.org/10.1109/ICDAR.2017.76>.
- [61] S. Chaillou, AI+Architecture Towards New Approach, Harvard University, 2019. <https://doi.org/10.9783/9781949057027-006>.
- [62] D. Piker, Kangaroo - Grasshopper. <http://www.grasshopper3d.com/group/kangaroo/> Accessed: August 2017.
- [63] A. Menges, Biomimetic design processes in architecture: Morphogenetic and evolutionary computational design, *Bioinspiration and Biomimetics*. 7 (2012) 15003. <https://doi.org/10.1088/1748-3182/7/1/015003>.
- [64] J.H. Jo, J.S. Gero, Space layout planning using an evolutionary approach, *Artificial Intelligence in Engineering*. 12 (1998) 149–162. [https://doi.org/10.1016/S0954-1810\(97\)00037-X](https://doi.org/10.1016/S0954-1810(97)00037-X).
- [65] Y.K. Yi, Dynamic coupling between a Kriging-based daylight model and building energy model, *Energy and Buildings*. 128 (2016) 798–808. <https://doi.org/10.1016/j.enbuild.2016.05.081>.
- [66] R. Correia, J.P. Duarte, A. Leitao, GRAMATICA: A general 3D shape grammar interpreter targeting the mass customization of housing, in: Proceedings of the 30th ECAADe Conference, Prague, Czech Republic, 2012: pp. 489–496. http://papers.cumincad.org/data/works/att/ecaade2012_273.content.pdf. Accessed: August 2018.
- [67] A.J. Fischer, Quelea: agent-based design for Grasshopper Agent-based design for Grasshopper. <https://www.food4rhino.com/app/quelea-agent-based-design-grasshopper>. Accessed: August 2018.
- [68] C. Gloor, PEDSIM - Pedestrian Crowd Simulation. <http://pedsim.silmaril.org/>. Accessed: August 2018.
- [69] N. Popov, Generative urban design with Cellular Automata and Agent Based Modelling, in: Proceedings of the 44th Annual Conference of the Architectural Science Association, Auckland, New Zealand, 2010. https://www.academia.edu/1434082/Generative_urban_design_with_cellular_automata_and_agent_based_modelling. Accessed: August 2018.
- [70] A. Turner, A. Penn, Encoding natural movement as an agent-based system: An investigation into human pedestrian behaviour in the built environment, *Environment and Planning B: Planning and Design*. 29 (2002) 473–490. <https://doi.org/10.1068/b12850>.
- [71] R.J. Dzeng, C.W. Lin, F.Y. Hsiao, Application of RFID tracking to the optimization of function-space assignment in buildings, *Automation in Construction*. 40 (2014) 68–83. <https://doi.org/10.1016/j.autcon.2013.12.011>.
- [72] H.Y. Lee, I.T. Yang, Y.C. Lin, Laying out the occupant flows in public buildings for operating efficiency, *Building and Environment*. 51 (2012) 231–242. <https://doi.org/10.1016/j.buildenv.2011.11.005>.
- [73] J.R. Chang, HyperCell: A Bio-inspired Design Framework for Real-time Interactive Architectures, Delft University of Technology, 2018. <https://doi.org/10.7480/abe.2018.1>.
- [74] M. Jain, A. Sanyal, S. Goyal, C. Chattopadhyay, G. Bhatnagar, Automatic Rendering of Building Floor Plan Images from Textual Descriptions in English, *Journal of Latex Class Files*. 14 (2015) 1–8. <http://arxiv.org/abs/1811.11938>.
- [75] P. Merrell, E. Schkufza, V. Koltun, Computer-generated residential building layouts, *ACM Transactions on Graphics (TOG)*. 29 (2010) 1. <https://doi.org/10.1145/1866158.1866203>.
- [76] A. Takizawa, Y. Miyata, N. Katoh, Enumeration of Floor Plans Based on a Zero-Suppressed Binary Decision Diagram, in: Proceedings of the 19th International Conference on Computer-Aided Architectural Design Research in Asia, Kyoto, Japan, 2014: pp. 25–44. <https://doi.org/10.1260/1478-0771.13.1.25>.
- [77] C. Anderson, C. Bailey, A. Heumann, D. Davis, Augmented space planning: Using procedural generation to automate desk layouts, *International Journal of Architectural Computing*. 16 (2018) 164–177. <https://doi.org/10.1177/1478077118778586>.
- [78] J.T. Christensen, The generation of possible space layouts, in: Proceedings of the 32nd ECAADe Conference, Newcastle upon Tyne, England, 2014: pp. 239–246. http://papers.cumincad.org/data/works/att/ecaade2014_100.content.pdf. Accessed: August 2018.
- [79] C. Lee, S. Ham, Automated system for form layout to increase the proportion of standard forms and improve work efficiency, *Automation in Construction*. 87 (2018) 273–286. <https://doi.org/10.1016/j.autcon.2017.12.028>.
- [80] C. Biagini, V. Donato, D. Pellis, Preliminary design through graphs: A Tool for Automatic Layout Distribution, *ICONARP International Journal of Architecture and Planning*. 2 (2014) 1–13. <http://iconarp.selcuk.edu.tr/iconarp/article/view/60>.

- [81] Y. Hsu, R.J. Krawczyk, Form Development with Spatial Character, in: Proceedings of the 22nd ECAADe Conference, Copenhagen, Denmark, 2004: pp. 1–8. http://papers.cumincad.org/cgi-bin/works/Show?2004_278.
- [82] H. Song, J. Ghaboussi, T.-H. Kwon, Architectural design of apartment buildings using the Implicit Redundant Representation Genetic Algorithm, *Automation in Construction*. 72 (2016) 166–173. <https://doi.org/10.1016/j.autcon.2016.09.001>.
- [83] S. Boonstra, K. van der Blom, H. Hofmeyer, M.T.M. Emmerich, Super-Structure and Super-Structure Free Design Search Space Representations for a Building Spatial Design in Multi-Disciplinary Building Optimisation, in: Electronic Proceedings of the 23rd International Workshop of the European Group for Intelligent Computing in Engineering, Krakow, Poland, 2016: pp. 1–10. <https://dSPACE.lboro.ac.uk/dSPACE-jspui/handle/2134/8337>. Accessed: June 2019.
- [84] M. Harada, A. Witkin, D. Baraff, Interactive Physically-Based Manipulation of Discrete/Continuous Models, in: Proceedings of the SIGGRAPH, Los Angeles, USA, 1995: pp. 199–208. <http://www-cgi.cs.cmu.edu/afs/cs.cmu.edu/Web/People/aw/pdf/discrete.pdf>. Accessed: August 2018.
- [85] G. Fortin, BUBBLE: Relationship Diagrams using Iterative Vector Approximation, in: Proceedings of the 15th Conference on Design Automation, Las Vegas, Nevada, 1978: pp. 145–151. <https://dl.acm.org/doi/10.5555/800095.803079>. Accessed: August 2018.
- [86] R. Koenig, M. Standfest, Evolutionary multi-criteria optimization for building layout planning: Exemplary application based on the PSSA framework, in: Proceedings of the 32nd ECAADe Conference, Newcastle upon Tyne, England, 2014: pp. 567–574. <https://doi.org/10.13140/2.1.4951.4888>.
- [87] G. Ślusarczyk, Graph-based representation of design properties in creating building floorplans, *Computer-Aided Design*. 95 (2018) 24–39. <https://doi.org/10.1016/j.cad.2017.09.004>.
- [88] G. Suter, F. Petrushevski, M. Šipetić, Operations on network-based space layouts for modeling multiple space views of buildings, *Advanced Engineering Informatics*. 28 (2014) 395–411. <https://doi.org/10.1016/j.aei.2014.06.004>.
- [89] X.Y. Wang, Y. Yang, K. Zhang, Customization and generation of floor plans based on graph transformations, *Automation in Construction*. 94 (2018) 405–416. <https://doi.org/10.1016/j.autcon.2018.07.017>.
- [90] G. Suter, Structure and spatial consistency of network-based space layouts for building and product design, *Computer-Aided Design*. 45 (2013) 1108–1127. <https://doi.org/10.1016/j.cad.2013.04.004>.
- [91] F. Regateiro, J. Bento, J. Dias, Floor plan design using block algebra and constraint satisfaction, *Advanced Engineering Informatics*. 26 (2012) 361–382. <https://doi.org/10.1016/j.aei.2012.01.002>.
- [92] I.D. Manthilake, Evolutionary building layout optimisation, Loughborough University, 2011. <https://dSPACE.lboro.ac.uk/dSPACE-jspui/handle/2134/8337>.
- [93] S. Shikder, A. Price, M. Mourshed, Interactive constraint-based space layout planning, in: Proceedings of 18th CIB World Building Congress, Salford, UK, 2010: pp. 112–122. http://www.irbnet.de/daten/iconda/CIB_DC24120.pdf. Accessed: August 2018.
- [94] Ö. Ülker, D. Landa-Silva, A 0/1 integer programming model for the office space allocation problem, *Electronic Notes in Discrete Mathematics*. 36 (2010) 575–582. <https://doi.org/10.1016/j.endm.2010.05.073>.
- [95] T.M. Loemker, Designing with Machines: solving architectural layout planning problems by the use of a constraint programming language and scheduling algorithms, in: Proceeding of The 2nd International Conference of the Arab Society for Computer Aided Architectural Design, Sharjah, United Arab Emirates, 2006: pp. 88–106. http://papers.cumincad.org/data/works/att/ascaad2006_paper7.content.pdf. Accessed: October 2018.
- [96] A. Schwarz, D.M. Berry, E. Shaviv, On the use of the automated building design system, *Computer-Aided Design*. 26 (1994) 747–762.
- [97] J. Roth, R. Hashimshony, Algorithms in graph theory and their use for solving problems in architectural design., *Computer-Aided Design*. 20 (1988) 373–381. [https://doi.org/10.1016/0010-4485\(88\)90214-X](https://doi.org/10.1016/0010-4485(88)90214-X).
- [98] J. Ruch, Interactive Space Layout: A Graph Theoretical Approach, in: Proceedings of the 15th Design Automation Conference, Las Vegas, Nevada, 1978: pp. 152–157. <https://doi.org/10.1109/DAC.1978.1585162>.
- [99] U. Flemming, S. Chien, Schematic Layout Design in SEED Environment, *Journal of Architectural Engineering*. 1 (1995) 162–169. [https://doi.org/10.1061/\(ASCE\)1076-0431\(1995\)1:4\(162\)](https://doi.org/10.1061/(ASCE)1076-0431(1995)1:4(162)).
- [100] X. Cao, Z. He, Y. Pan, Automated design of house-floor layout with distributed planning, *Computer-Aided Design*. 22 (1990) 213–222. [https://doi.org/10.1016/0010-4485\(90\)90050-M](https://doi.org/10.1016/0010-4485(90)90050-M).

- [101] K. Van Der Blom, S. Boonstra, H. Hofmeyer, M. Emmerich, A SUPER-STRUCTURE BASED OPTIMISATION APPROACH FOR BUILDING SPATIAL DESIGNS, in: Proceedings of the VII European Congress on Computational Methods in Applied Sciences and Engineering-ECCOMAS VII, Crete Island, Greece, 2017: pp. 3409–3422. <https://doi.org/10.7712/100016.2044.10063>.
- [102] A.N. Elshafei, HOSPITAL LAYOUT AS A QUADRATIC ASSIGNMENT PROBLEM, *Journal of the Operational Research Society*. 28 (1977) 167–179. <https://doi.org/10.1057/jors.1977.29>.
- [103] C.M. Herr, R.C. Ford, Cellular automata in architectural design: From generic systems to specific design tools, *Automation in Construction*. 72 (2016) 39–45. <https://doi.org/10.1016/j.autcon.2016.07.005>.
- [104] C. Langenhan, M. Weber, M. Liwicki, F. Petzold, A. Dengel, Graph-based retrieval of building information models for supporting the early design stages, *Advanced Engineering Informatics*. 27 (2013) 413–426. <https://doi.org/10.1016/j.aei.2013.04.005>.
- [105] K. Knecht, R. Koenig, Generating floor plan layouts with k–d trees and evolutionary algorithms, in: Proceedings of the GA2010–13th Generative Art Conference, Milano, Italy, 2010: pp. 238–253. https://www.generativeart.com/on/cic/GA2010/2010_18.pdf.
- [106] M.H. Zawadzki, K. Tateyama, I. Nishikawa, The constraints satisfaction problem approach in the design of an architectural functional layout, *Engineering Optimization*. 43 (2011) 943–966. <https://doi.org/10.1080/0305215X.2010.527005>.
- [107] B. Yao, H. Chen, C.-K. Cheng, R. Graham, Floorplan representations, *ACM Transactions on Design Automation of Electronic Systems*. 8 (2003) 55–80. <https://doi.org/10.1145/606603.606607>.
- [108] R. Lopes, T. Tutenel, R.M. Smelik, K.J. De Kraker, R. Bidarra, T. Hague, A constrained growth method for procedural floor plan generation, in: Proceedings of the 11th International Conference on Intelligent Games and Simulation, Leicester, United Kingdom, 2010: pp. 13–23. <https://graphics.tudelft.nl/~rafa/myPapers/bidarra.GAMEON10.pdf>. Accessed: August 2018.
- [109] J. Roth, R. Hashimshony, A. Wachman, Turning a graph into a rectangular floor plan, *Building and Environment*. 17 (1982) 163–173. [https://doi.org/10.1016/0360-1323\(82\)90037-3](https://doi.org/10.1016/0360-1323(82)90037-3).
- [110] R. Sharpe, Optimum Space Allocation Within Buildings, *Building Science*. 8 (1973) 201–205. [https://doi.org/10.1016/0007-3628\(73\)90001-7](https://doi.org/10.1016/0007-3628(73)90001-7).
- [111] W. Peng, F. Zhang, Machines' Perception of Space: Employing 3D Isovist Methods and a Convolutional Neural Network in Architectural Space Classification, in: Proceedings of the 37th Annual Conference of the Association for Computer Aided Design in Architecture, Cambridge MA, 2017: pp. 474–481. http://papers.cumincad.org/cgi-bin/works/paper/acadia17_474. Accessed: October 2019.
- [112] E. Rodrigues, A.R. Gaspar, Á. Gomes, An approach to the multi-level space allocation problem in architecture using a hybrid evolutionary technique, *Automation in Construction*. 35 (2013) 482–498. <https://doi.org/10.1016/j.autcon.2013.06.005>.
- [113] K. Matsuzaki, T. Irohara, K. Yoshimoto, Heuristic algorithm to solve the multi-floor layout problem with the consideration of elevator utilization, *Computers & Industrial Engineering*. 36 (1999) 487–502. [https://doi.org/10.1016/S0360-8352\(99\)00144-8](https://doi.org/10.1016/S0360-8352(99)00144-8).
- [114] P. Raftery, M. Keane, J. O'Donnell, Calibrating whole building energy models: An evidence-based methodology, *Energy and Buildings*. 43 (2011) 2356–2364. <https://doi.org/10.1016/j.enbuild.2011.05.020>.
- [115] Netherlands Standardization Institute, NEN-16798-1 Energy performance of buildings - Part 1: Indoor environmental input parameters for design and assessment of energy performance of buildings addressing indoor air quality, thermal environment, lighting and acoustics - Module M1-6, 2015. <https://connect.nen.nl/Standard/Detail/207600?compId=10037&collectionId=0>. Accessed: March 2018.
- [116] T. Du, S. Jansen, M. Turrin, A. Van Den Dobbelsteen, Impact of space layout on energy performance of office buildings coupling daylight with thermal simulation, in: Proceedings of the 13th REHVA World Congress CLIMA, Burcharest, Romania, 2019: pp. 1–8. <https://doi.org/10.1051/e3sconf/201911103077>.
- [117] T. Du, S. Jansen, M. Turrin, A. van den Dobbelsteen, Effects of Architectural Space Layouts on Energy Performance: A Review, *Sustainability*. 12 (2020) 1829. <https://doi.org/10.3390/su12051829>.
- [118] Netherlands Standardization Institute, NEN-EN-ISO 13790 Energy performance of buildings- Calculation of energy use for space heating and cooling, 2008. <https://connect.nen.nl/Standard/Detail/119188?compId=10037&collectionId=0>.
- [119] Netherlands Standardization Institute, NEN-EN 15193-1: Energy performance of buildings -Energy requirements for lighting -Part 1: Specifications, Module M9, 2017. <https://connect.nen.nl/Standard/Detail/3526912?compId=10037&collectionId=0>. Accessed: October 2017.

- [120] Netherlands Standardization Institute, NEN-EN 16798-3: Energy performance of buildings- Ventilation for buildings- Part 3: Ventilation for non-residential buildings. Performance requirements for ventilation and room-conditioning systems, 2017. <https://connect.nen.nl/Standard/Detail/3531933?compId=10037&collectionId=0>. Accessed: October 2017.
- [121] B. Coffey, Using Building Simulation and Optimization to Calculate Lookup Tables for Control, University of California, Berkeley, 2011. <https://escholarship.org/content/qt1202p562/qt1202p562.pdf>. Accessed: March 2019.
- [122] P. Westermann, R. Evins, Surrogate modelling for sustainable building design – A review, *Energy and Buildings*. 198 (2019) 170–186. <https://doi.org/10.1016/j.enbuild.2019.05.057>.
- [123] R.E. Edwards, J. New, L.E. Parker, B. Cui, J. Dong, Constructing large scale surrogate models from big data and artificial intelligence, *Applied Energy*. 202 (2017) 685–699. <https://doi.org/10.1016/j.apenergy.2017.05.155>.
- [124] W. Tian, R. Choudhary, G. Augenbroe, S.H. Lee, Importance analysis and meta-model construction with correlated variables in evaluation of thermal performance of campus buildings, *Building and Environment*. 92 (2015) 61–74. <https://doi.org/10.1016/j.buildenv.2015.04.021>.
- [125] Y.J. Kim, Comparative study of surrogate models for uncertainty quantification of building energy model: Gaussian Process Emulator vs. Polynomial Chaos Expansion, *Energy and Buildings*. 133 (2016) 46–58. <https://doi.org/10.1016/j.enbuild.2016.09.032>.
- [126] T. Wortmann, Genetic evolution vs. function approximation: Benchmarking algorithms for architectural design optimization, *Journal of Computational Design and Engineering*. 6 (2019) 414–428. <https://doi.org/10.1016/j.jcde.2018.09.001>.
- [127] A. Prada, A. Gasparella, P. Baggio, On the performance of meta-models in building design optimization, *Applied Energy*. 225 (2018) 814–826. <https://doi.org/10.1016/j.apenergy.2018.04.129>.
- [128] E. Asadi, M.G. da Silva, C.H. Antunes, L. Dias, L. Glicksman, Multi-objective optimization for building retrofit: A model using genetic algorithm and artificial neural network and an application, *Energy and Buildings*. 81 (2014) 444–456. <https://doi.org/10.1016/j.enbuild.2014.06.009>.
- [129] A.P. Ramallo-González, D.A. Coley, Using self-adaptive optimisation methods to perform sequential optimisation for low-energy building design, *Energy and Buildings*. 81 (2014) 18–29. <https://doi.org/10.1016/j.enbuild.2014.05.037>.
- [130] W. Wang, H. Rivard, R. Zmeureanu, An object-oriented framework for simulation-based green building design optimization with genetic algorithms, *Advanced Engineering Informatics*. 19 (2005) 5–23. <https://doi.org/10.1016/j.aei.2005.03.002>.
- [131] R. Choudhary, A. Malkawi, P.Y. Papalambros, A hierarchical design optimization framework for building performance, in: *Proceedings of the 8th International IBPSA Conference, Eindhoven, Netherlands, 2003*: pp. 179–186. http://www.ibpsa.org/proceedings/BS2003/BS03_0179_186.pdf. Accessed: February 2019.

5 Relationship analysis and design optimisation of space layouts to improve the energy performance of office buildings

This chapter is adapted from a journal paper which is under review, titled as 'Relationship analysis and design optimisation of space layouts to improve the energy performance of office buildings'.

ABSTRACT Features of buildings that impact the energy performance have been broadly studied due to the urgency in reducing buildings' energy consumption. Space layouts were also proven to have an impact on the building energy performance. However, the relationship between different space layouts and their consequent energy demands has not been systematically studied so far. This study thoroughly investigates such relationship. To do so, a computational method is developed both to analyse such relationship and to design space layout with optimised energy performance. The computational method includes the following parts: a method to generate space layout; the assessment method integrating daylighting simulation and energy simulation in Amsterdam, a temperate climate; the automation method to integrate the former two parts. For the relationship analysis, four types of design indicators of space layout are proposed, both for the overall layout and for each function.

A Design of Experiments (DOE) is performed with 500 evaluations, and its results are used to analyse the relationship. The relationship analysis shows that regarding the effect on energy demands, corners are more influential than the other locations, and offices are more influential than the other functions, and façade area to floor area ratio is more influential than the other types of design indicator. Additionally, the optimisation for minimising heating, cooling and lighting demands is performed. The resulting improvement from optimisation is up to 54% for lighting demand, 51% for heating demand and 38% for cooling demand. The optimisation results also validate the relationship identified based on DOE results.

ABBREVIATIONS

PCA: performative computational architecture; GH: Grasshopper; mF: modeFRONTIER; DOE: Design of Experiments; ULH: Uniform Latin Hypercube; SOM: Self-Organising Maps; ff-ratio: façade area to floor area ratio; floor-orientation: floor area ratio per orientation e.g. floor-S; façade-orientation: façade area ratio per orientation, e.g. façade-S; ff-orientation: façade area to floor area ratio per orientation, e.g. ff-S; hd-orientation: height to depth ratio per orientation, e.g. hd-S; floor-function-orientation: floor area ratio per function per orientation, e.g. floor-office-S; façade-function-orientation: façade area ratio per function per orientation, e.g. façade-office-S; ff-function-orientation: façade area to floor area ratio per function per orientation, e.g. ff-office-S; hd-function-orientation: height to depth ratio per function per orientation, e.g. hd-office-S.

5.1 Introduction

With the recent advances in computational fields, the performative computational architecture (PCA) has become more and more popular for architectural design and shown high potential in improving building performance [1].

PCA supports architectural design by allowing designers to explore different design alternatives by gaining awareness of their performances. With PCA, the building's geometry and material properties are parametrised, and designers vary the design parameters to satisfy the design objectives relevant to certain building performance. It aims to find the proper building form that satisfies the defined objectives. PCA includes three phases: form generation, performance evaluation, and optimisation [1]. Different design parameters of buildings have been explored for PCA, including geometry, façade, materials, shading, orientation, window to wall ratio (WWR), etc. Different objectives have been studied, like energy, daylight, thermal comfort, life cycle cost, logistics, etc.

Current studies have proven that using PCA to optimise building energy performance helps to reduce energy demands highly, as shown in [2].

Space layout design is one of the most important tasks in architectural design, taking place around 'scheme design' and 'design development' in the early design phase [3,4]. The architectural space layout refers to the allocation of different functions, and it is decided based on the placement of interior partitions as well as exterior walls. Some studies have shown that space layouts impact building energy performance highly. Five space layouts for an office building in the UK were compared in [5], and resulted in the biggest difference of 57% in the heating demand for peak winter and 67% in the lighting demand for peak summer. Various layouts for a library building with the same geometry were simulated and compared in Turkey in [6], and resulted in the biggest difference of 19% in the heating demand for one day, 20% in the cooling demand for one day, and 10% for the lighting demand for one day. 11 layouts with different function allocations for an office building were compared in three climates in [7], and resulted in the biggest difference of 12% in annual heating demand, 10% in annual cooling demand, and 65% in annual lighting demand.

Designing space layout with PCA would help to improve the energy performance of building. Some studies have proven this potential. The study of [6] optimised space layouts with the objectives to improve energy and daylighting performance, as well as the functionality of layout. The study of [8] developed a method to automatically generate space layout and assess the thermal performance of the generated layout. However, among the studies relevant to space layout design, only a few focused on energy performance, as shown in the review study of [9]. Similarly, among the studies for building energy performance optimisation, only a few focused on space layout design, as shown in the review study of [1]. Additionally, among the several studies [5,6,8,10–12], which considered both space layout design and energy performance, no studies evaluated the relationships between space layouts and energy demands.

Thus, space layouts proved to have an impact on the building energy performance. However, the relationship between different space layout and the consequent energy demands has not been systematically studied so far. This paper aims to draw the generic knowledge about the relationship between space layout and energy performance.

According to our previous review papers [9,13], the performance of space layout can be categorised into functionality and energy performance. The functional performance includes indicators relevant to safety, logistics, adjacency, connection,

view, and acoustic, etc. The energy performance includes the indicators relevant to energy. In order to draw the generic knowledge about the relationship between space layout and energy performance, the functional performance is not considered in the methodology. Thus, instead of using a layout for a specific building for which the functional requirements need to be satisfied, a layout with much less constraints than a specific layout is used for test.

A Design of Experiments (DOE) is a set of techniques used to efficiently guide a choice of experiments, and an experiment refers to a series of tests in which the input variable values are changed according to a certain rule to identify the reasons for the changes in outputs [14]. DOE helps to perform a smart exploration of the design space and obtain good statistical understanding of the problem by identifying the sources of variation. So, DOE is used to draw the relationship between space layout and energy performance in this study. This paper develops a computational method for DOE and optimisation of space layout design in Section 5.2. The design indicators of space layouts are proposed to represent the characteristics of space layout in Section 5.3. With the developed computational method, a DOE is run, and its results are used to analyse the relationship between space layout and energy demands in Section 5.4. Finally, the optimisation for minimising heating, cooling and lighting demands is run in Section 5.5.

Chapter 4 developed a comprehensive methodology regarding how to address the requirements of space layout, in terms of both functional and energy requirements. This is key for applications in practice. Differently, this chapter presents a method which contributes to the theoretical understanding of the relationship between space layout and energy performance. Thus, the space variants in this chapter are generated by changing geometric variables which are relevant to energy performance; while functional requirements (such as space connection, adjacency, etc.) are not taken into account.

Additionally, although both energy indicators (like energy demands) and comfort indicators (like PMV and indicators relevant to daylighting comfort) are mentioned as the objectives of the optimisation for energy performance in Section 4.2.4, only energy demands for lighting, cooling and heating are used as objectives for optimisation in this chapter. The energy demands for heating and cooling are based on set-point temperatures for heating and cooling, which in turn are related to the thermal comfort given the different functions of the layout. The temperature set-points are deliberately differentiated between functions, since otherwise less changes in energy demand can be expected from different layouts.

5.2 Method for DOE and optimisation

The computational method for DOE and optimisation includes three parts: the generation of space layout, the energy and daylighting performance assessment, and the automation of generation and assessment. The workflow and three parts are explained in the following sub-sections. Once the overall method is set, it allows the authors to run DOE and analyse the relationship between space layout and energy demands based on DOE results, as well as the optimisation for minimising energy demands.

5.2.1 Workflow of the method

The method is operated with the integration of Grasshopper (GH) [15] and modeFRONTIER (mF) [16]. The simulation is operated in GH with the use of Ladybug Tools and specifically Honeybee [17,18], which use Radiance (5.2.1) [19] and Daysim [20] for daylighting simulation and EnergyPlus (9.0.0) [21] for energy simulation. EnergyPlus has been proven to have low accuracy in daylighting simulation [22], so its integration with Radiance and Daysim is necessary. A detailed simulation is shown in Section 5.4. The mF [16] is used to process the automation, optimisation, and data post-process and analysis. It provides a platform to enable the automation of space layout generation and performance assessment, a suite of DOE, optimisation algorithms, and tools for data analysis.

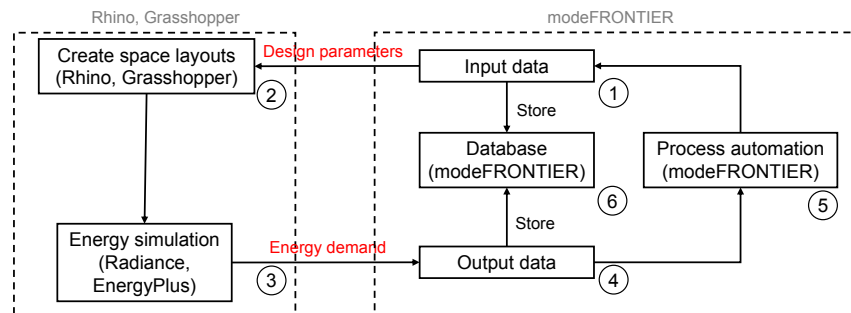
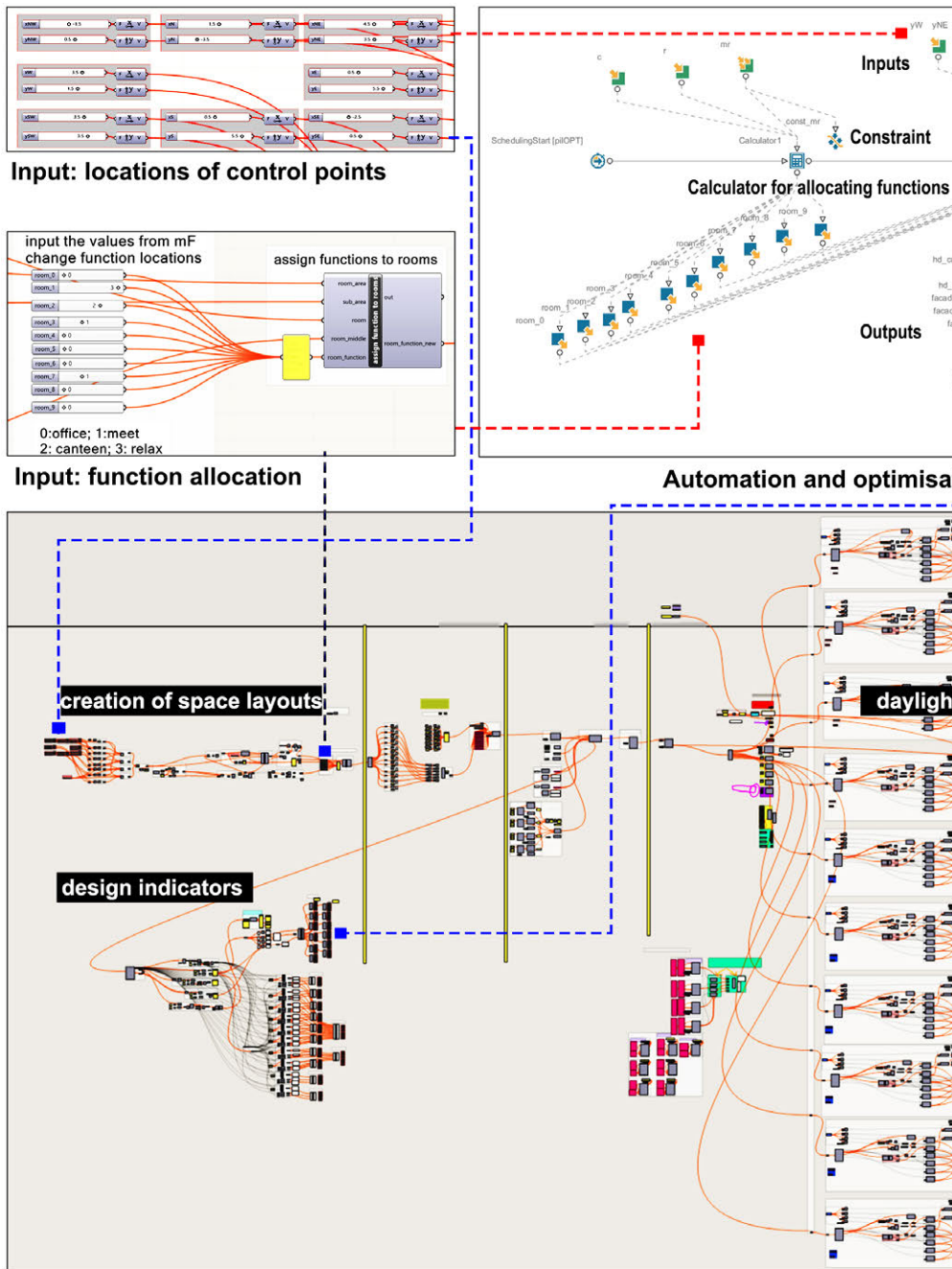
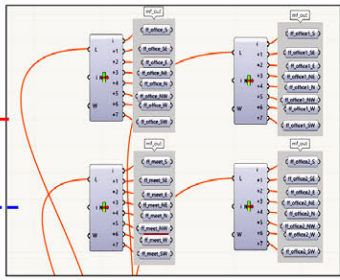
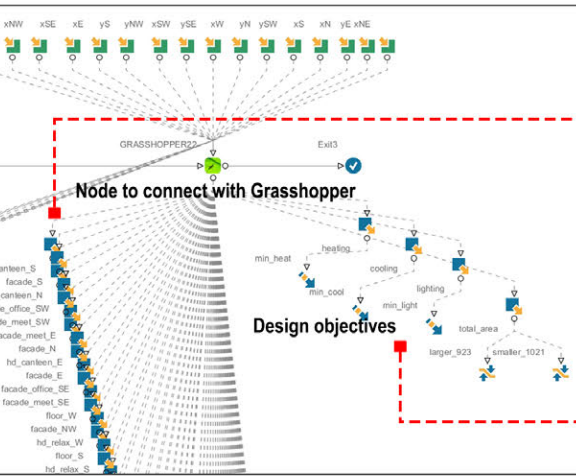

FIG. 5.1 Integration procedure of the method for DOE and optimisation



Creation of space layouts and

FIG. 5.2 Workflow of the method for DOE and optimisation



Output: design indicators

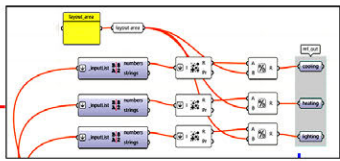

Output: energy demand

Simulation by using modeFRONTIER

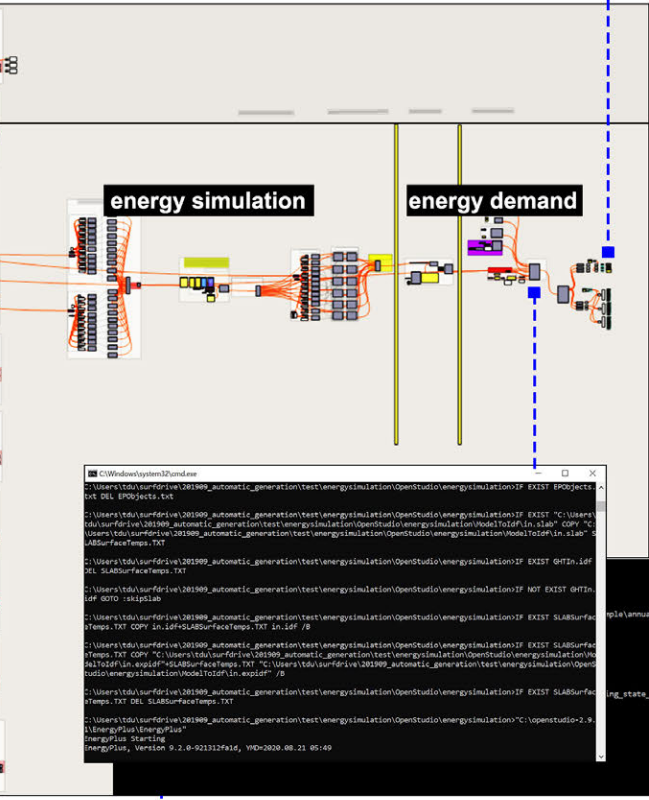
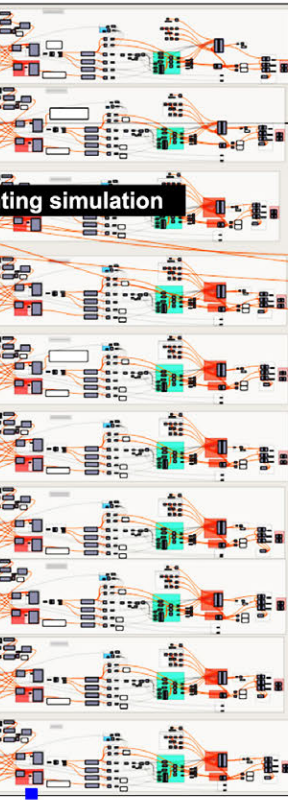

```

C:\Windows\system32\cmd.exe
C:\Users\tda\userdrive\201909_automatic_generation\test\energy\simulation\OpenStudio\energy\simulation>IF EXIST EPObject
DEL EPObject.txt
C:\Users\tda\userdrive\201909_automatic_generation\test\energy\simulation\OpenStudio\energy\simulation>IF EXIST "C:\Users\tda\userdrive\201909_automatic_generation\test\energy\simulation\OpenStudio\energy\simulation\NodeToIdIn_slab" COPY "C:\Users\tda\userdrive\201909_automatic_generation\test\energy\simulation\OpenStudio\energy\simulation\NodeToIdIn_slab" %User%\FaceTemp.txt
C:\Users\tda\userdrive\201909_automatic_generation\test\energy\simulation\OpenStudio\energy\simulation>IF EXIST GHTIn_idf DEL SLABSurfaceTemp.txt
C:\Users\tda\userdrive\201909_automatic_generation\test\energy\simulation\energy\simulation>IF NOT EXIST GHTIn_idf GHTD -skipslab
C:\Users\tda\userdrive\201909_automatic_generation\test\energy\simulation\OpenStudio\energy\simulation>IF EXIST SLABSurfaceTemp.txt COPY In_idf=SLABSurfaceTemp.txt In_idf /%
C:\Users\tda\userdrive\201909_automatic_generation\test\energy\simulation\OpenStudio\energy\simulation>IF EXIST SLABSurfaceTemp.txt COPY "C:\Users\tda\userdrive\201909_automatic_generation\test\energy\simulation\OpenStudio\energy\simulation\NodeToIdIn_slab" %User%\FaceTemp.txt
C:\Users\tda\userdrive\201909_automatic_generation\test\energy\simulation\OpenStudio\energy\simulation>IF EXIST SLABSurfaceTemp.txt DEL SLABSurfaceTemp.txt
C:\Users\tda\userdrive\201909_automatic_generation\test\energy\simulation\OpenStudio\energy\simulation>"C:\openstudio-2.9.1\EnergyPlus\EnergyPlus"
EnergyPlus Starting
EnergyPlus Version 9.2.0-921312f3d_VHD-2020.08.21 05:49
  
```

Energy and daylighting simulation in Grasshopper

Energy and daylighting simulation in EnergyPlus and Radiance

As shown in Figure 5.1, the integration procedure of the method is as follows:

- 1 the design parameters, which are used to control the form of space layout, are input to GH;
- 2 the space layout is created based on the inputs;
- 3 the created space layout is simulated for heating, cooling and lighting demands in Radiance/Daysim and EnergyPlus, with the climate data of Amsterdam;
- 4 the calculated energy demands are output to mF to be defined as design objectives; in mF, the design objectives are manually chosen to be 'min' in the interface, i.e. minimising energy demands;
- 5 the automation process continues in mF based on optimisation algorithm or designed set of evaluations for DOE, and new design parameters are sent back to GH and the loop continues;
- 6 with the iteration of the integration process, the input data and output data are saved in the database, which is used for further relationship analysis.

The detailed workflow is shown in Figure 5.2, which will be explained in the following sub-sections.

5.2.2 Generation of space layout

In order to investigate what specifically impacts the energy performance, space layouts are generated with the goal of testing a large set of variations featuring geometric properties that may impact the energy performance. They are generated to make rather extreme variations; they are not generated with a focus on functionality and direct applicability in practice.

The first step of the method focuses on the identification of parametric design variables for space layout, to be used later in the parametric generation of different alternatives of space layout. As shown in [13], the design variables of space layout can be classified into the ones with a fixed boundary and the ones with a non-fixed boundary. In order to include and test design variables as many as possible, the design variables with a non-fixed boundary are used. Therefore, the layout boundary, interior partition, and function allocation are changed. As explained in Introduction,

the design variables regarding functionality like adjacency and connection are not tested, in order to focus on design variables directly related with energy demands and thus better understand their relationships. Both internal layout and boundary layout are varied for the generation of layout, which aim to change the design indicators relevant to energy for each room and the layout. Changing the layout boundary results in the change of orientations of the layout (façade orientation on each floorplan side) and each room (façade orientation of each room), as well as the depth of the layout in different orientations and the depth of each room. In order to better compare the results between different rooms in terms of design indicators and energy demands, it is necessary to keep the room area the same. Thus, the layout is split into 10 rooms with the same room area, which results in the change of internal layouts.

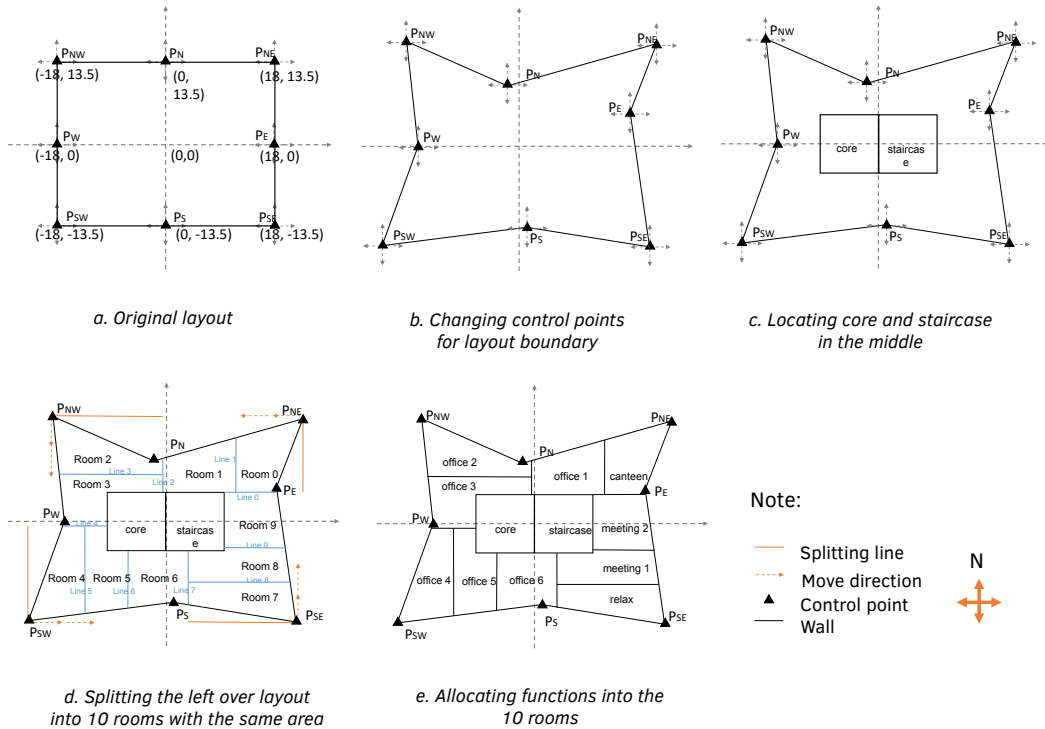

FIG. 5.3 Procedure to create layouts

The second step of the method shown in Section 5.2.1 focuses on the parametric generation of the different alternatives of space layout. The method to generate layout is implemented based on a reference layout, which was previously published

by the authors [7]. The layout includes 12 rooms, i.e. 6 offices, 2 meeting rooms, 1 canteen, 1 break room, 1 core and 1 staircase. Each room is 9 meters wide and 9 meters deep. Core and staircase are located in the middle on purpose, and corridor is not considered in this layout, in which most rooms can be connected with core and staircase. The detailed steps to generate space layout are shown in Figure 5.3 and explained as follows.

The layouts generated with the method can be highly irregular, like Room 2 in Figure 5.3-d, which is inapplicable directly for practical use. However, we do not limit the shape of the generated layout to be regular for the purpose of application in practice. Because in order to analyse the relationship between space layout and energy demands, the free change in the layout and room shape is necessary in order to obtain a wide variance in each design indicator.

The starting layout boundary is shown in Figure 5.3-a, with the layout area of 972 m², which is kept fixed during the following steps. The procedure to change layouts is shown as follows.

5.2.2.1 Changing layout boundary

In order to include the variance in floor area and façade area in different orientations, 8 points are used to control the layout boundary, as shown in Figure 5.3-a and 5.3-b. Each point can move along the x axis for maximum 8.5 m left and 8.5 m right, and along the y axis for maximum 6.5 m up and 6.5 m down, with the step of 1.0 m. They control the variation of the layout boundary in 8 orientations, i.e. S, SE, E, NE, N, NW, W, and SW.

5.2.2.2 Locating core and staircase

After the layout boundary is changed, the layout is ready to be split into rooms. As shown in Figure 5.3-c, two square rooms located in the middle of the layout are used as core and staircase, with the original point as the middle point for their adjacent boundary. The room area of core and staircase keeps to be 1/12 of the total layout area.

5.2.2.3 Splitting the left-over layout

As shown in Figure 5.3-d, the left-over layout is split as follows: Line-0, the horizontal line starting from the vertex of staircase, is used as the starting line, and the splitting line moves in the counter clockwise direction, until the area covered by Line-0, splitting line and layout boundary is larger than $1/12$ of the layout area, and the splitting line is Line-1 and the split room is Room-0; the splitting line continues moving until the area covered by Line-1, splitting line and layout boundary is larger than $1/12$ of the layout area, and the splitting line is Line-2 and the split room is Room-1; the splitting line continues moving until all 10 rooms are created. When the splitting line arrives around one corner of the layout, if the covered area is not big enough for one room with the splitting line moving, the splitting line changes the splitting direction and turned 90° in counter clockwise direction to continue splitting until the split room area is big enough. In order to make sure the algorithm works well, a test is added: if the room area difference between two rooms is bigger than 10%, the generated layout is reported as an error, and the following steps are skipped to save computational time.

Although the algorithm considers different scenarios regarding the different layout shapes, one scenario is not considered as shown in Figure 5.4: when using line 5 to split the SW corner, a concave shape appears and each room, i.e. S0 (20 m²) and S1 (49 m²), is not big enough for a single room (58 m²), while the sum of the two rooms (69 m²) is bigger than a room; this situation is ignored in this study.

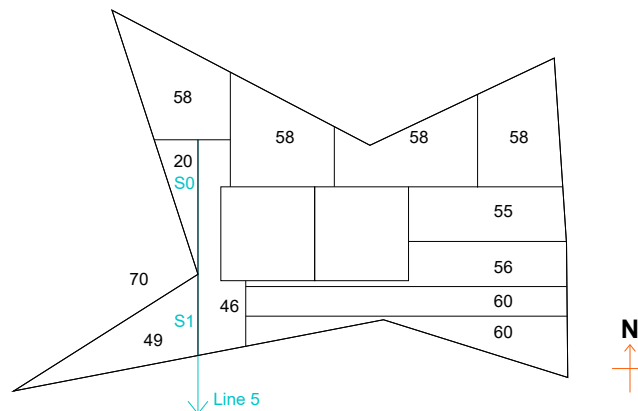

FIG. 5.4 Ignored scenario for splitting the layout.
Note: The numbers (m²) in the layout are the corresponding room areas

5.2.2.4 Allocating functions

After the left-over layout is split into 10 rooms, the left-over 4 functions, i.e. office, meeting room, canteen, break room, need to be allocated to the 10 rooms, as shown in Figure 5.3-e. This step is accomplished with a calculator in mF, as shown in Figure 5.2. The allocating procedure is as follows: first, one room among 10 rooms is selected as canteen; then another room among the left-over 9 rooms is selected as break room; after this, another 2 rooms among the left-over 8 rooms are selected as meeting rooms; finally, the left-over 6 rooms are used as offices. After this step, the layout is generated and is input to Radiance/Daysim and EnergyPlus for daylighting and energy simulation.

5.2.3 Energy and daylighting performance assessment

The third step of the method regards the performance assessment based on simulation. In this study, the annual heating, cooling and lighting demands for the whole layout are used to assess energy performance. The information about energy and daylight performance simulation are shown in our previous study [23], and the workflow is shown in Figure 5.2. The climate data of Amsterdam in the Netherlands as a temperate climate is used.

Daylighting simulation and energy simulation is integrated in this study. The electric lighting schedule is calculated based on the difference between the target illuminance and the received daylighting illuminance, and the calculated lighting schedule is used for energy simulation for each room. The screen installed outside the windows is used for shading on all facades, and external vertical illuminance is used to determine the state of shading system.

As for ventilation, the outdoor air flow rate is $0.37 \text{ dm}^3/\text{s}\cdot\text{m}^2$ (per floor area) plus $8.89 \text{ dm}^3/\text{s}\cdot\text{person}$, as recommended in [24]. A heat exchanger is used with a heat recovery efficiency of 0.7. The humidity threshold is 25%-60% as recommended in [25]. The infiltration rate is 0.2 air changes per hour and middle rooms have no infiltration. The applied maximum occupancy and equipment load density for each function are shown in Table 5.1. The used maximum equipment load densities are the values defined in Honeybee for office buildings, which were assigned based on the data collected by the U.S. Department of Energy for Commercial Reference Buildings [26].

TABLE 5.1 Maximum internal gains of different functions

Spaces	Max. occupancy (persons/room)	Max. equipment load density (W/m ²)
Office	6	6.9
Meeting room	12	4
Canteen	9	48
Break room	9	0.8
Staircase	3	0
Core	3	3

TABLE 5.2 Detailed information for simulation

Construction of wall and floor											
Name	Layers (from inside to outside)		U value (W/m ² ·K)								
Interior wall	19mm Gypsum board + air space resistance+ 19mm Gypsum board;		2.56								
Interior floor	Acoustic tile + ceiling air space resistance + 100mm lightweight concrete;		1.45								
Exterior wall	100mm brick + 25mm air cavity + 140mm insulation + 150mm concrete;		0.22								
Glazing properties											
Location	U value (W/m ² K)	Visible transmittance	g value								
Amsterdam	1.65	0.76	0.7								
Reflectance of interior surfaces											
Floor	Ceiling	Wall									
0.1	0.8	0.5									
Set points											
Function	Set point for Heating (°C)	Set point for Cooling (°C)	Target illuminance (lux)								
Office	22	24	500								
Meeting	22	24	300								
Canteen	20	26	200								
Break	20	26	200								
Core	18	28	150								
Staircase	18	28	150								
Occupancy schedule fraction											
Hour	1-8	9	10	11	12	13	14	15	16	17	18-24
Office	0	0.7	0.8	1	1	0	1	1	0.8	0.8	0
Meeting	0	0	0.5	0.5	0	0	0	0.5	0.5	0	0
Canteen	0	0	0	0	0	1	0	0	0	0	0
Break	0	0	0	0	0	1	0	0	0	0	0
Core	0	0.5	0	0	0	0	0	0	0	0.5	0
Staircase	0	0.5	0	0	0	0	0	0	0	0.5	0

The detailed information about the simulation is shown in Table 5.2, regarding constructions, glazing properties, reflectance of interior surfaces. The constructions are assigned according to the references of [24,27–29], the local building design standards in the Netherlands. Additionally, different functions' set-points for heating, cooling, and lighting, and occupancy schedule fraction are also presented in Table 5.2. The heat flow between different floors is not considered, so floors and ceilings are adiabatic. The WWR of the simulation model is kept to be 40%.

Differently from our previous work [23] which took into account a fixed geometric layout, for the present study the daylighting simulation model selects dynamically three lighting zones based on yearly daylighting illuminance for each room which varies between layouts. Similarly, an algorithm is developed to select dynamically the windows of the same room with different façade orientations in order to assign them to two different shading groups, the maximum number allowed by Ladybug Tools. In the case of rooms with more than two façade orientations, like some corner rooms, the algorithm groups the windows of the facades with the smallest angle difference between their façade normal.

Differently from the previous study [23], in order to save computational time for the huge amount of simulation used in DOE and optimisation, in this study less accurate daylighting simulation parameters are used. The test points are located with a distance of 1.5 m. Radiance parameters are presented in Table 5.3 [30]. As full interior solar distribution cannot be handled correctly for concave shape in EnergyPlus, the 'full exterior with reflections' is used for solar distribution, as explained in [19].

TABLE 5.3 Radiance parameters used for daylighting simulation

-ab	-ad	-as	-ar	-aa
2	512	128	16	0.25

Note: -ab: ambient bounces; -ad: ambient divisions; -as: ambient super-samples; -ar: ambient resolution; -aa: ambient accuracy.

5.2.4 Automation of generation and assessment

The final step of the method regards the automation of the iterative loop of space layout generation and energy performance assessment. In order to realise the automation, mF is integrated with GH with a node which was customised for the integration by ESTECO, as shown in Figure 5.2. The automation process continues

the loop of generation and assessment, based on optimisation algorithm or designed set of evaluations for DOE. The elements needed for automation, in terms of design variables, objective functions, constraints are shown as follows. Concurrent evaluations are used to speed up the process.

5.2.4.1 Design variables

As shown in Table 5.4, the design variables include two categories, i.e. the ones for changing layout boundary as explained in Section 5.2.2.1, and the ones for changing function allocation as explained in Section 5.2.2.4. The design variables for layout boundary are the values that the 8 control points change along x and y axis with the interval of 1 m. Regarding the ones for function allocation, 2 design variables (c and r) represent the locations of canteen and break room respectively, and one vector input variable (mr) includes two design variables (mr[0] and mr[1]), and they represent the locations of two meeting rooms respectively.

TABLE 5.4 Design variables and their domains

Category	Design variables	Data type	Upper bound	Lower bound	Intervals	Symbol
Layout boundary	Value of 8 control points changed in X axis	float	8.5m	-8.5m	1m	xN, xNW, xNE, xS, xSW, xSN, xW, xE
	Value of 8 control points changed in Y axis	float	6.5m	-6.5m	1m	yN, yNW, yNE, yS, ySW, ySN, yW, yE
Function allocation	Location of canteen	Integer	0	9	1	c
	Location of break room	Integer	0	8	1	r
	Location of meeting room 1	Integer	0	7	1	mr[0]
	Location of meeting room 2	Integer	0	7	1	mr[1]

5.2.4.2 Outputs and constraints

The outputs include annual heating demand, cooling demand and lighting demand for the whole layout per layout area. The constraints include the one for layout area, i.e. changing the layout variant within a 5% difference of the layout area of the reference layout (923 m² to 1021 m²), and the one to avoid two meeting rooms locating in the same room. The detailed description of outputs and constraints are shown in Table 5.5.

TABLE 5.5 Outputs and constraints

Disciplines	Performance criteria	Constraints	Symbol
Architecture	Locations of two meeting rooms are different	$mr[0]-mr[1]>0$	Const_mr
	Layout area (m ²) is larger than 923 m ²	>923	Larger_923
	Layout area (m ²) is smaller than 1021 m ²	<1021	Smaller_1021
Energy performance	Heating demand (kWh/m ²)	-	Min_heat
	Cooling demand (kWh/m ²)	-	Min_cool
	Lighting demand (kWh/m ²)	-	Min_light

5.2.4.3 Concurrent evaluations

As shown in the study [13], the computational time is a big issue for the energy performance optimisation. The computational time for each evaluation in this study is quite high, with the integration of daylighting simulation and energy simulation. The computational time of each evaluation varies from 1 h to 2 h depending on the used computer property. In order to speed up simulation and reduce the whole computational time, four computers are used simultaneously, i.e. four concurrent evaluations are run at the same time. The details of the four computers are as follows: one computer uses the processor of 2x Intel(R) Xeon(R) CPU E5-2680 v2 @ 2.80GHz, 20 cores, and 40 logical processors; two computers use the processor of 2x Intel(R) Xeon(R) CPU E5-2680 v3 @ 2.50GHz, 24 cores, and 48 logical processors; one computer uses the processor of 2x Intel(R) Xeon(R) CPU E5-2680 v4 @ 2.40GHz, 28 cores and 56 logical processors. Thus, the whole computational time is highly reduced, being around ¼ of the original computation time.

5.3 Proposed design indicators

Design indicators are needed to quantify the architectural properties of space layout into numerically measurable features. The properties of space layout include dimensions of layout, interior partition, and locations of different functions [13]. The commonly used design indicators relevant to building energy efficiency include the proportion of a building's length to width [31], the ratio of external wall area to floor area [32], and the proportion of a building's envelope area to its volume [33].

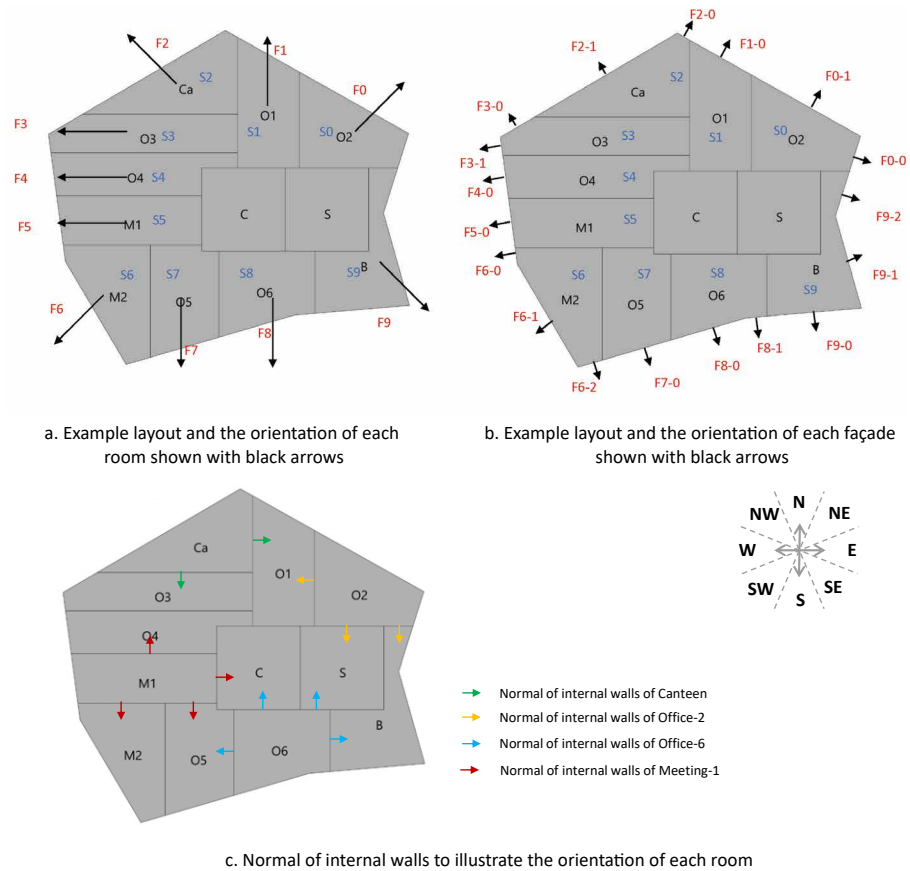

FIG. 5.5 An example layout illustrating the calculation of design indicators

Note: O1: office-1, O2: office-2, O3: office-3, O4: office-4, O5: office-5, O6: office-6, M1: meeting-1, M2: meeting-2, Ca: canteen, B: break room, C: core, S: staircase

In this study, the design indicators of façade area ratio, floor area ratio, façade area to floor area ratio (ff-ratio), and height to depth ratio are considered for different orientations. Additionally, design indicators are used for two categories: the first category is for the whole layout, and the other is for each function. For each indicator, 8 orientations are considered, i.e. S, SE, E, NE, N, NW, W, and SW, as shown in Figure 5.5. There are two methods to separate orientations, as black arrows show in Figure 5.5: one is based on the normal of interior walls of each room (Figure 5.5-a), and the other one is based on the façade orientation of each room (Figure 5.5-b). As for the first method, the following procedure is used to define the orientation of each room based on its interior walls as shown in Figure 5.5-c, in which the arrows show the normal of internal walls of each room: the arrows of internal walls

of Office-6 orient N, W and E, without S, so Office-6 is defined as orientated S; the arrows of internal walls of Meeting-1 orient N, S and E, without W, so Meeting-1 is defined as orientated W; the arrows of internal walls of Office-2 orient only W and S, so Office-2 is defined as orientated NE; the arrows of internal walls of Canteen orient only E and S, so Canteen is defined as orientated NW.

TABLE 5.6 Nomenclature

	Description		Description
F_{0-F_9}	Façade area of each room, and room number varies from 0 to 9	ff_7	ff-ratio of office-5
F_{0-0}, F_{0-1}	Area of each façade segment of Room 0	ff_8	ff-ratio of office-6
F_{1-0}	Area of the façade segment of Room 1	$ff - office - S$	Façade area to floor area ratio of South for offices
F_{2-0}, F_{2-1}	Area of each façade segment of Room 2	height	Room height of the tested model, i.e. 3 meters
F_{3-0}, F_{3-1}	Area of each façade segment of Room 3	hd_{6-2}	Height to depth ratio of one façade of Meeting-2
F_{4-0}	Area of the façade segment of Room 4	hd_7	Height to depth ratio of the façade of Office-5
F_{5-0}	Area of the façade segment of Room 5	hd_{8-0}, hd_{8-1}	Height to depth ratio of each façade of Office-6
$F_{6-0}, F_{6-1}, F_{6-2}$	Area of each façade segment of Room 6	hd_{9-0}	Height to depth ratio of one façade of Break room
F_{7-0}	Area of each façade segment of Room 7	$hd - S$	Height to depth ratio of South for the whole layout
F_{8-0}, F_{8-1}	Area of each façade segment of Room 8	$hd - office - S$	Height to depth ratio of South for offices
$F_{9-0}, F_{9-1}, F_{9-2}$	Area of each façade segment of Room 9	$Normal_{ff-S}$	Normalisation of calculated ff-ratios over all rooms in South
$facade - S$	Façade area ratio of South for the whole layout	$Normal_{hd-S}$	Normalisation of calculated height to depth ratios over all rooms in South
$facade - office - S$	Façade area ratio of South for offices	$Normal_{hd-office-S}$	Normalisation of calculated height to depth ratios over all offices in South
$floor - S$	Floor area ratio of South for the whole layout	$Normal_{ff-office-S}$	Normalisation of calculated ff-ratios over all offices in South
$floor - office - S$	Floor area ratio of South for offices	S_0-S_9	Room area of different rooms, and room number varies from 0 to 9
$ff - S$	Façade area to floor area ratio of South for the whole layout		

In this study, the design indicators which are more relevant to façades, i.e. façade area ratio and height to depth ratio in this case, are calculated based on the façade orientation. The other indicators which are also relevant to floors, i.e. floor area ratio and ff-ratio, are calculated based on the normal of internal walls. Each design indicator is explained in details in the following sub-sections. The nomenclature used in these indicators is listed in Table 5.6.

5.3.1 Design indicators for the whole layout

The design indicators shown in this section are calculated for the whole layout without considering the difference between functions. Taking the layout in Figure 5.5 as an example, the detailed calculation of these design indicators is shown as follows.

5.3.1.1 Floor area ratio per orientation

As the floor area ratio per orientation (floor-orientation) is calculated based on room area, the orientation of each room is determined based on the orientation of internal walls as shown in Figure 5.5-a. Taking *floor – S* as an example, Office-5 and Office-6 face South in this layout as shown in Figure 5.5-a. The *floor – S* is calculated as follows:

$$floor - S = \frac{S_7 + S_8}{S_0 + S_1 + S_2 + S_3 + S_4 + S_5 + S_6 + S_7 + S_8 + S_9} \quad (1)$$

5.3.1.2 Façade area ratio per orientation

The façade area ratio per orientation (façade-orientation) is calculated based on each façade segment, and the orientation of each segment is determined individually as shown in Figure 5.5-b. Taking the calculation of *façade – S* as an example, Office-5, Office-6, Break room, and one facade of Meeting-2 face South. The *façade – S* is calculated as follows:

$$façade - S = \frac{F_{6-2} + F_{7-0} + F_{8-0} + F_{8-1} + F_{9-0}}{F_0 + F_1 + F_2 + F_3 + F_4 + F_5 + F_6 + F_7 + F_8 + F_9} \quad (2)$$

5.3.1.3 Façade area to floor area ratio per orientation

The façade area to floor area ratio per orientation (ff-orientation) is calculated based on the ratio of each room, and its orientation is determined based on the orientation of each room as shown in Figure 5.5-a. The calculation procedure of this indicator is as follows: firstly, the ff-ratio is calculated for each room; then, the value of each room is normalised over all rooms in the same orientation by multiplying its floor area ratio, and the normalised values in the same orientation are summed up; finally, the value of each orientation is normalised over all orientations by multiplying the ratio of the floor area ratio of the orientation over all orientations, in order to be compared with other orientations. Taking $ff - S$ as an example, Office-5 and Office-6 face South in this layout, so $ff - S$ is calculated as follows.

- **Step 1:** Calculating ff-ratio for each room in South. In this case, office-5 and office-6 face South.

For office-5:

$$ff_7 = \frac{F_7}{S_7} \quad (3)$$

For office-6:

$$ff_8 = \frac{F_8}{S_8} \quad (4)$$

- **Step 2:** Normalising the ratios over all rooms in South by multiplying the floor area ratio:

$$Normal_{ff-S} = ff_7 * \frac{S_7}{S_7 + S_8} + ff_8 * \frac{S_8}{S_7 + S_8} \quad (5)$$

- **Step 3:** Normalising the value for South over all orientations by multiplying the floor area ratio:

$$ff - S = Normal_{ff-S} * \frac{S_7 + S_8}{S_0 + S_1 + S_2 + S_3 + S_4 + S_5 + S_6 + S_7 + S_8 + S_9} \quad (6)$$

The function is simplified as follows:

$$ff - S = \frac{F_7 + F_8}{S_0 + S_1 + S_2 + S_3 + S_4 + S_5 + S_6 + S_7 + S_8 + S_9} \quad (7)$$

5.3.1.4 Height to depth ratio per orientation

The height to depth ratio per orientation (hd-orientation) is calculated based on the façade orientation as shown in Figure 5.5-b. Similar to ff-orientation, this indicator is also normalised, with façade area ratio as weight factor. Taking $hd - S$ as an example, one façade of Meeting-2, Office-5, Office-6, and one façade of Break room face South in this layout, so $hd - S$ is calculated as follows.

- **Step 1:** Calculating the height to depth ratio for each façade facing South:

Meeting-2 has one facade facing South:

$$hd_{6-2} = \frac{\text{height}}{D_{6-2}} \quad (8)$$

Office-5 has one facade facing South:

$$hd_{7-0} = \frac{\text{height}}{D_{7-0}} \quad (9)$$

Office-6 has two façades facing South, and each facade is calculated as follows:

$$hd_{8-0} = \frac{\text{height}}{D_{8-0}} \quad (10)$$

$$hd_{8-1} = \frac{\text{height}}{D_{8-1}} \quad (11)$$

Break room has one facade facing South:

$$hd_{9-0} = \frac{\text{height}}{D_{9-0}} \quad (12)$$

- **Step 2:** Normalising each ratio over all rooms in South by multiplying façade area ratio:

$$\begin{aligned} Normal_{hd-S} = & hd_{6-2} * \frac{F_{6-2}}{F_{6-2} + F_{7-0} + F_{8-0} + F_{8-1} + F_{9-0}} + hd_{7-0} * \frac{F_{7-0}}{F_{6-2} + F_{7-0} + F_{8-0} + F_{8-1} + F_{9-0}} \\ & + hd_{8-0} * \frac{F_{8-0}}{F_{6-2} + F_{7-0} + F_{8-0} + F_{8-1} + F_{9-0}} + hd_{8-1} * \frac{F_{8-1}}{F_{6-2} + F_{7-0} + F_{8-0} + F_{8-1} + F_{9-0}} \\ & + hd_{9-0} * \frac{F_{9-0}}{F_{6-2} + F_{7-0} + F_{8-0} + F_{8-1} + F_{9-0}} \end{aligned} \quad (13)$$

- **Step 3:** Normalising the value for South over all orientations by multiplying the façade area ratio:

$$hd - S = Normal_{hd-S} * \frac{F_{6-2} + F_{7-0} + F_{8-0} + F_{8-1} + F_{9-0}}{F_0 + F_1 + F_2 + F_3 + F_4 + F_5 + F_6 + F_7 + F_8 + F_9} \quad (14)$$

The function is simplified as follows:

$$hd - S = height * \frac{F_{6-2}}{D_{6-2}} + \frac{F_{7-0}}{D_{7-0}} + \frac{F_{8-0}}{D_{8-0}} + \frac{F_{8-1}}{D_{8-1}} + \frac{F_{9-0}}{D_{9-0}} / (F_0 + F_1 + F_2 + F_3 + F_4 + F_5 + F_6 + F_7 + F_8 + F_9) \quad (15)$$

5.3.2 Design indicators for each function

The same types of indicators for the whole layout are calculated for each function in this section, and their calculation methods are similar to the ones for the layout. Thus, the calculation of the indicators per function is shown only with an example as follows.

5.3.2.1 Floor area ratio per function per orientation

Regarding the calculation of floor area ratio per function per orientation (floor-function-orientation), the *floor – office – S* is used as an example, following the orientation definition shown in Figure 5.5-a:

$$floor - office - S = \frac{S_7 + S_8}{S_0 + S_1 + S_3 + S_4 + S_7 + S_8} \quad (16)$$

5.3.2.2 Façade area ratio per function per orientation

Regarding the calculation of façade area ratio per function per orientation (facade-function-orientation), the calculation of *facade – office – S* is used as an example, with the orientation shown in Figure 5.5-b:

$$façade - office - S = \frac{F_{7-0} + F_{8-0} + F_{8-1}}{F_0 + F_1 + F_3 + F_4 + F_7 + F_8} \quad (17)$$

5.3.2.3 Façade area to floor area ratio per function per orientation

Regarding the calculation of façade area to floor area ratio per function per orientation (ff-function-orientation), the weight factor used for normalisation is calculated based on the area of rooms with the same function. The calculation of *ff-office-S* is used as an example following the orientation definition shown in Figure 5.5-a and it is calculated as follows:

- **Step 1:** Calculating ff-ratio for each office in South. In this case, Office-5 and Office-6 face South.

For Office-5:

$$ff_7 = \frac{F_7}{S_7} \quad (18)$$

For Office-6:

$$ff_8 = \frac{F_8}{S_8} \quad (19)$$

- **Step 2:** Normalising the ratios over all offices in South by multiplying floor area ratio:

$$Normal_{ff-office-S} = ff_7 * \frac{S_7}{S_7 + S_8} + ff_8 * \frac{S_8}{S_7 + S_8} \quad (20)$$

- **Step 3:** Normalising the value for South over all offices by multiplying floor area ratio:

$$ff - office - S = Normal_{ff-office-S} * \frac{S_7 + S_8}{S_0 + S_1 + S_3 + S_4 + S_7 + S_8} \quad (21)$$

The function is simplified as follows:

$$ff - office - S = \frac{F_7 + F_8}{S_0 + S_1 + S_3 + S_4 + S_7 + S_8} \quad (22)$$

5.3.2.4 Height to depth ratio per function per orientation

Regarding the calculation of height to depth ratio per function per orientation (hd-function-orientation), the weight factor used for normalisation is calculated based on the facade area of rooms with the same function. The *hd-office-S* is used as an example with the orientation shown in Figure 5-b and it is calculated as follows:

- **Step 1:** Calculating the height to depth ratio for each facade of offices facing South.

Office 5 has one facade facing South:

$$hd_{7-0} = \frac{\text{height}}{D_{7-0}} \quad (23)$$

Office 6 has two façades facing South, and each one is calculated as follows:

$$hd_{8-0} = \frac{\text{height}}{D_{8-0}} \quad (24)$$

$$hd_{8-1} = \frac{\text{height}}{D_{8-1}} \quad (25)$$

- **Step 2:** Normalising these ratios over all offices facing South by multiplying with façade area ratio:

$$Normal_{hd-office-S} = hd_{7-0} * \frac{F_{7-0}}{F_7 + F_8} + hd_{8-0} * \frac{F_{8-0}}{F_7 + F_8} + hd_{8-1} * \frac{F_{8-1}}{F_7 + F_8} \quad (26)$$

- **Step 3:** Normalising the value for South over all offices by multiplying the façade area ratio:

$$hd - office - S = Normal_{hd-office-S} * \frac{F_7 + F_8}{F_0 + F_1 + F_3 + F_4 + F_7 + F_8} \quad (27)$$

The function is simplified as follows:

$$hd - office - S = \text{height} * \frac{F_7}{D_7} + \frac{F_8}{D_8} / (F_0 + F_1 + F_3 + F_4 + F_7 + F_8) \quad (28)$$

5.4 DOE and relationship analysis

A DOE is run in this section with the method shown in Section 5.2, and based on the DOE results, we analyse the relationship between space layout and energy demands.

5.4.1 DOE algorithm and results

The method shown in Section 5.2 is used for DOE: the design variables are inputs; the energy demands and the design indicators shown in Section 5.3 are outputs. In addition to the energy demand of the layout shown in Table 5.5, the energy demand of each function, i.e. function-energy, which is calculated as the energy demand of all rooms with the same function per room area (kWh/m²), is also used as outputs for DOE.

5.4.1.1 Algorithm for DOE sampling

In order to get the maximum information using the minimum number of samples, DOE sampling is necessary to guide the choice of samples. Uniform Latin Hypercube (ULH) [34] is a stochastic DOE algorithm and the designs created by ULH are relatively uniformly distributed over the variable range by minimising correlations between input variables and maximising the distance between the generated designs. So, ULH is used for DOE sampling with 500 evaluations in this study.

5.4.1.2 Results of DOE

Although 500 evaluations were planned for DOE, some errors happened. These errors were caused by the ignored scenario for splitting layouts as shown in Section 5.2.2.3. Totally 448 evaluations were completed, among which 90 designs are feasible, i.e. satisfying the layout area constraint. The total computational time is 210h 18m, around 8.8 days.

5.4.2 Method for relationship analysis

The relationship analysis is conducted between design indicators and their corresponding energy demands. This study aims to extract the relationships between design indicators and energy demands, and also compare their relationships to identify which design indicator is the most influential for the corresponding energy demand.

Some scatter plots between design indicators and energy demands show clear linearity, and linear correlations are expected. Thus, the following two methods are used for relationship analysis: Pearson correlation [35] and regression analysis [36]. Pearson correlation is used to identify the linear relationship between two variables, like between ff-ratio and heating demand. Multi-variate linear regression analysis is used to identify the relationship between several predictors (like heating demand of offices, heating demand of meeting rooms, heating demand of canteen) and one response (like the heating demand of the layout). By comparing the regression coefficients of different predictors, we can identify which predictor is more influential on the response than the others.

The Pearson correlation is a measure of linear association between two variables, with a value between -1 and 1 [37]. The value of correlation coefficient represents the strength of correlation of the tested two variables. If the absolute value is within 0.1 to 0.3, they have a low correlation; if the absolute value is within 0.3 to 0.5, they have a medium correlation; if the absolute value is within 0.6 to 1.0, they have a high correlation. In this study, we only focus the medium and high correlation, i.e. the coefficient is higher than 0.30. Multi-variate linear regression analysis requires that the predictors cannot have perfect collinearity. So, it is only used in Section 5.4.3.2 for the relationship between the energy demand of the layout and energy demand of each function, as it is the only case among all cases tested in this paper that has no collinearity.

5.4.3 Analysis of the relationship between energy demands

To obtain a better understanding of the DOE results, the relationship between different energy demands of the layout (simulated for Amsterdam climate) and different functions are analysed with the method of Pearson correlation in this section.

5.4.3.1 Relationship between different energy demands of the layout

The correlation coefficients between energy demands and ff-ratio for the layout, resulting from Pearson correlation analysis, are shown in Figure 5.6-a. To better illustrate their relationship, the scatter plots are shown in Figure 5.6-b to 5.6-g.

	heating	cooling	lighting
cooling	0.48	/	/
lighting	-0.65	-0.12	/
ff-ratio	0.79	0.41	-0.46

a Matrix of correlation coefficients between energy demands and ff-ratio for the layout



FIG. 5.6 Matrix of correlation coefficients and scatter plots, for energy demands and ff-ratio for the layout

As shown in Figure 5.6, the energy demands and ff-ratio for the layout are analysed for their correlations, and the following correlations are found:

- **Ff-ratio for the layout has a positive correlation with heating demand, as well as with cooling demand, as shown in Figure 5.6-b and 5.6-c:** A compact building, i.e. with a low ff-ratio, helps to save heating and cooling demands.
- **Ff-ratio for the layout has a negative correlation with lighting demand, as shown in Figure 5.6-d:** More façade area, i.e. with a high ff-ratio, helps to receive more daylight.
- **The correlation between heating demand and cooling demand is positive, as shown in Figure 5.6-f:** A building with a low heating demand is highly possible to be compact, and it results in a low cooling demand.
- **The correlation between thermal demands and lighting demand is negative, as shown in Figure 5.6-e and 5.6-g:** A building with a low thermal (heating and cooling) demand is highly possible to be compact, and this results in a high lighting demand.

5.4.3.2 Relationship between energy demand of the layout and energy demand of each function

Multi-variate linear regression analysis is conducted regarding the relationship between energy demand of the layout and energy demand per function. The energy demands for each function (like heating demand of offices, heating demand of meeting rooms, heating demand of canteen, heating demand of break room, heating demand of core, and heating demand of staircase) are used as predictors, and the energy demand of the layout (like heating demand of the layout) is used as response. The regression analysis is run three rounds for heating demand, cooling demand and lighting demand respectively. The method of enter is used for each regression analysis.

The resulting regression coefficients and R-square values for each round of analysis are shown in Table 5.7. The regression coefficient indicates the influence of each predictor on the response, i.e. the energy demand per function on the variance of the energy demand for the layout. By comparing the coefficients, we can identify which function is the most influential on the variance of the energy demand for the layout. It is clear that compared to other functions, offices have the highest influence on the energy demands of the layout, followed by meeting rooms. The reason for offices' high influence on the energy demands of the layout is that the function has

the highest requirements for lighting, heating and cooling and it also has the most rooms compared to other functions, followed by meeting rooms.

TABLE 5.7 The regression coefficients of three rounds of regression analysis for heating, cooling, and lighting demand respectively, between energy demand of the layout and energy demands of different functions

	Regression Coefficients		
	Heating	Cooling	Lighting
(Constant)	0.000	0.000	0.121
Office	0.500	0.500	0.500
Meeting	0.167	0.167	0.167
Canteen	0.083	0.083	0.083
Break	0.083	0.083	0.083
Core	0.083	0.083	/
Staircase	0.083	0.083	/
R-square	1	1	1

Note: Core and Staircase have the same lighting demands among different layouts, so their lighting demands are not used for the regression analysis.

5.4.4 Analysis of the relationship between energy demands and design indicators for the layout

The four types of design indicators for the whole layout, as explained in Section 5.3.1, are analysed for their correlations with the energy demands for the layout (simulated for Amsterdam). Comparing the four types of design indicators, the energy demands of the layout have no clear correlation with floor-orientation, as well as with façade-orientation and hd-orientation. Clear correlations are shown between energy demands and ff-orientation as shown in Figure 5.7-a, and their correlations are analysed as follows.

- **Ff-orientations have positive correlations with thermal demands:** A smaller ff-orientation means compact rooms, and it results in low heating and cooling demands.
- **Ff-orientations have negative correlations with lighting demand:** If the ff-orientation is smaller, the façade area of the relevant room is smaller and it results in less daylighting. So more electric lighting is needed as a consequence.

- **Heating demand is more sensitive to ff-orientations than cooling and lighting demands:** The coefficients between heating demand and ff-orientations are higher than cooling and lighting demands. For instance, the coefficient is 0.68 between ff-SE and heating demand. while it is 0.35 for cooling demand and -0.33 for lighting demand.
- **Corners are more influential on energy demands compared to the other locations:** Ff-corners have higher coefficients than other locations. For instance, ff-SE shows clearer linearity with heating demand compared to ff-S, as shown in Figure 5.7-b and 5.7-c. This is because corner rooms have higher façade area than the other rooms, resulting higher influence on energy demands.

	heating	cooling	lighting	ff-S	ff-SE	ff-E	ff-NE	ff-N	ff-NW	ff-W
cooling	0.48	/	/	/	/	/	/	/	/	/
lighting	-0.65	-0.11	/	/	/	/	/	/	/	/
ff-S	0.28	0.18	-0.17	/	/	/	/	/	/	/
ff-SE	0.68	0.35	-0.33	-0.06	/	/	/	/	/	/
ff-E	0.36	0.12	-0.19	-0.06	0.19	/	/	/	/	/
ff-NE	0.69	0.39	-0.36	0.20	0.41	0.19	/	/	/	/
ff-N	0.28	0.07	-0.36	-0.28	0.24	-0.14	0.16	/	/	/
ff-NW	0.63	0.45	-0.30	0.26	0.25	0.27	0.43	-0.17	/	/
ff-W	0.19	-0.01	-0.11	-0.16	0.14	-0.09	0.07	-0.04	0.08	/
ff-SW	0.55	0.42	-0.35	0.22	0.32	0.13	0.28	0.16	0.30	-0.38

a Matrix of correlation coefficients between energy demands and ff-orientation for the layout

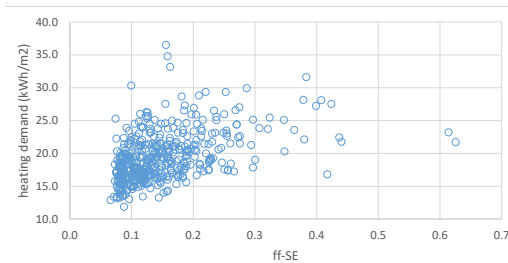

b Scatter plot for ff-SE and heating demand

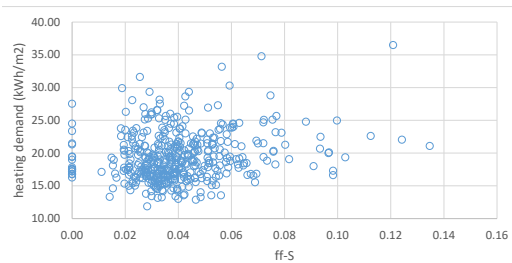

c Scatter plot for ff-S and heating demand

FIG. 5.7 Matrix of correlation coefficients and scatter plots, for energy demands and ff-orientations for the layout

5.4.5 Analysis of the relationship between energy demands and design indicators for each function

The four types of design indicators for each function, as explained in Section 5.3.2, are analysed for their correlations with the energy demands of the corresponding function (simulated for Amsterdam climate), as shown in Figure 5.8. Comparing the four types of design indicators, the energy demands for each function have no clear correlation with facade-function-orientation, as well as with floor-function-orientation and hd-function-orientation. Similarly to the correlations for the layout in Section 5.4.4, clear correlations are shown between energy demands for each function and ff-function-orientation as shown in Figure 5.8, and the following correlations are found:

- **Corners are more influential on the energy demands for each function compared to the other locations:** Corner rooms have higher coefficients than the other rooms. The reason is the same as the correlation between ff-orientations and energy demands as explained in Section 5.4.4.
- **Ff-function-corners have negative correlations with lighting demand per function and positive correlations with heating and cooling demands:** It has the similar reasons to ff-corners as shown in Section 5.4.4.

	O-heat	O-cool	O-light	ff-O-S	ff-O-SE	ff-O-E	ff-O-NE	ff-O-N	ff-O-NW	ff-O-W
O-cool	0.355	\	\	\	\	\	\	\	\	\
O-light	-0.818	-0.222	\	\	\	\	\	\	\	\
ff-O-S	-0.06	-0.01	0.058	\	\	\	\	\	\	\
ff-O-SE	0.308	0.316	-0.401	-0.182	\	\	\	\	\	\
ff-O-E	0.08	0.101	0.034	-0.148	0	\	\	\	\	\
ff-O-NE	0.378	-0.015	-0.318	-0.035	-0.131	-0.158	\	\	\	\
ff-O-N	0.045	-0.159	-0.038	-0.265	-0.083	-0.113	-0.03	\	\	\
ff-O-NW	0.43	0.088	-0.286	-0.079	-0.089	0.002	-0.1	-0.174	\	\
ff-O-W	0.027	-0.036	0.078	-0.11	-0.069	-0.068	-0.047	-0.09	-0.106	\
ff-O-SW	0.362	0.385	-0.436	-0.073	0.058	-0.106	-0.031	-0.073	-0.055	-0.194

a Matrix of correlation coefficients between energy demands of offices and ff-office-orientations (ff-O-orientations)

	M-heat	M-cool	M-light	ff-M-S	ff-M-SE	ff-M-E	ff-M-NE	ff-M-N	ff-M-NW	ff-M-W
M-cool	0.424	\	\	\	\	\	\	\	\	\
M-light	-0.797	-0.538	\	\	\	\	\	\	\	\
ff-M-S	-0.28	0.053	0.093	\	\	\	\	\	\	\
ff-M-SE	0.19	0.558	-0.384	-0.156	\	\	\	\	\	\
ff-M-E	-0.101	-0.136	0.208	-0.211	-0.147	\	\	\	\	\
ff-M-NE	0.404	0.121	-0.3	-0.09	-0.086	-0.182	\	\	\	\
ff-M-N	-0.024	-0.358	0.061	-0.149	-0.114	-0.193	-0.185	\	\	\
ff-M-NW	0.577	0.143	-0.406	-0.09	-0.07	-0.128	-0.107	-0.077	\	\
ff-M-W	-0.058	-0.01	0.137	-0.141	-0.062	-0.108	-0.067	-0.147	-0.121	\
ff-M-SW	0.233	0.243	-0.321	-0.141	-0.118	-0.117	-0.069	-0.106	-0.048	-0.066

b Matrix of correlation coefficients between energy demands of meeting rooms and ff-meeting-orientations (ff-M-orientations)

	C-heat	C-cool	C-light	ff-C-S	ff-C-SE	ff-C-E	ff-C-NE	ff-C-N	ff-C-NW	ff-C-W
C-cool	0.708	\	\	\	\	\	\	\	\	\
C-light	-0.721	-0.587	\	\	\	\	\	\	\	\
ff-C-S	-0.382	-0.126	0.181	\	\	\	\	\	\	\
ff-C-SE	0.224	0.533	-0.372	-0.15	\	\	\	\	\	\
ff-C-E	-0.145	-0.152	0.215	-0.173	-0.112	\	\	\	\	\
ff-C-NE	0.388	0.174	-0.289	-0.147	-0.096	-0.111	\	\	\	\
ff-C-N	-0.054	-0.269	0.054	-0.193	-0.125	-0.145	-0.124	\	\	\
ff-C-NW	0.563	0.201	-0.351	-0.15	-0.097	-0.112	-0.096	-0.125	\	\
ff-C-W	-0.098	-0.151	0.263	-0.164	-0.106	-0.123	-0.105	-0.138	-0.107	\
ff-C-SW	0.309	0.458	-0.311	-0.138	0.09	-0.104	-0.088	-0.116	-0.09	-0.098

c Matrix of correlation coefficients between energy demands of canteen and ff-canteen-orientations (ff-C-orientations)

	B-heat	B-cool	B-light	ff-B-S	ff-B-SE	ff-B-E	ff-B-NE	ff-B-N	ff-B-NW	ff-B-W
B-cool	0.847	\	\	\	\	\	\	\	\	\
B-light	-0.76	-0.776	\	\	\	\	\	\	\	\
ff-B-S	-0.385	-0.25	0.112	\	\	\	\	\	\	\
ff-B-SE	0.118	0.435	-0.348	-0.141	\	\	\	\	\	\
ff-B-E	-0.103	-0.148	0.148	-0.185	-0.119	\	\	\	\	\
ff-B-NE	0.488	0.348	-0.342	-0.154	-0.099	-0.13	\	\	\	\
ff-B-N	-0.022	-0.174	0.089	-0.186	-0.119	-0.157	-0.131	\	\	\
ff-B-NW	0.512	0.324	-0.345	-0.14	-0.09	-0.118	-0.098	-0.119	\	\
ff-B-W	0.091	0.025	0.119	-0.124	-0.079	-0.104	-0.087	-0.105	-0.079	\
ff-B-SW	0.241	0.383	-0.296	-0.133	-0.085	-0.112	-0.094	-0.113	-0.085	-0.075

d Matrix of correlation coefficients between energy demands of break room and ff-break-orientations (ff-B-orientations)

FIG. 5.8 Matrix of correlation coefficients, between energy demands of each function and ff-function-orientations

Comparing the coefficients of different functions in Figure 5.8 a-d, it is strange that the coefficients of offices and meeting rooms are lower than the values of canteen and break room. The correlations between ff-ratio in NW and heating demand are used as an example to figure out the reason, as shown in Figure 5.9. Much clearer linearity is shown for canteen (Figure 5.9-c) and break room (Figure 5.9-d),

compared to offices (Figure 5.9-a) and meeting rooms (Figure 5.9-b). In comparison, clear linearity is shown for a **single** office (Figure 5.9-e) and meeting room (Figure 5.9-f). Therefore, the reason for the lower coefficient for offices and meeting rooms is that office has 6 rooms and meeting has 2 rooms, while canteen and break room only have one room. The influence of ff-ratio of offices and meeting rooms are undermined by the room numbers.

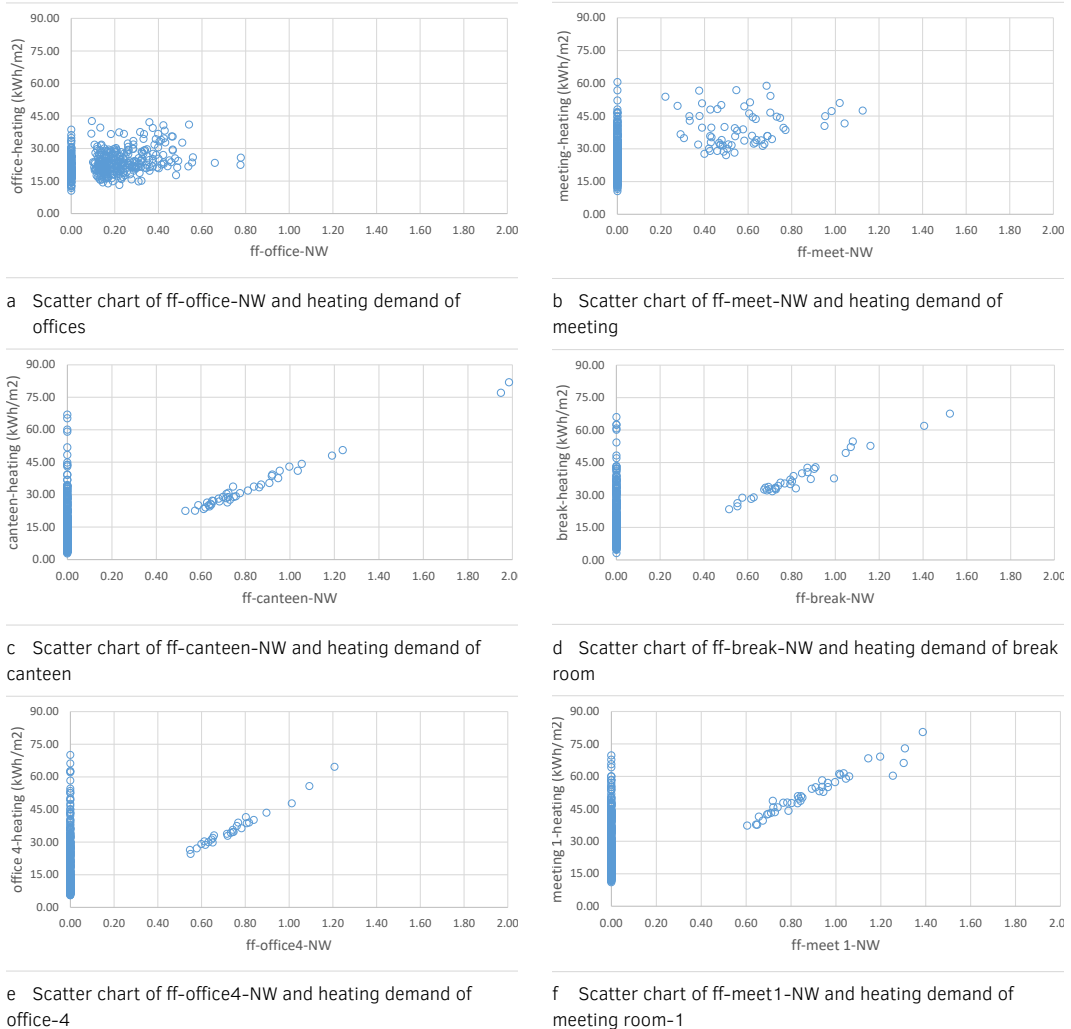

FIG. 5.9 Matrix of correlation coefficients, between energy demands of canteen and all design indicators for canteen
Note: The zero ff-ratio in these figures means that in the layout, no room is located facing that specific orientation. For instance, if ff-office-NW is zero, it means that in the layout no office is oriented NW, and the orientation of the room is defined by the normal of internal walls as Figure 5.5-a shows.

5.4.6 Comparison between four types of design indicators

Based on the former analysis in Section 5.4.3-5.4.5, the ff-ratio shows higher influence on energy demands, compared to the other three types of design indicators. To better compare the four types of design indicators, the correlations between each design indicator **for one single room** and the corresponding energy demand (simulated for Amsterdam climate) are analysed.

	C-heat	C-cool	C-light	facade-C-S	facade-C-SE	facade-C-E	facade-C-NE	facade-C-N	facade-C-NW	facade-C-W
C-cool	0.689	\	\	\	\	\	\	\	\	\
C-light	-0.73	-0.605	\	\	\	\	\	\	\	\
facade-C-S	-0.263	0.136	-0.022	\	\	\	\	\	\	\
facade-C-SE	-0.073	0.046	0.042	-0.153	\	\	\	\	\	\
facade-C-E	-0.063	-0.004	0.119	-0.196	-0.077	\	\	\	\	\
facade-C-NE	0.06	-0.058	-0.011	-0.155	-0.072	-0.052	\	\	\	\
facade-C-N	0.28	-0.108	-0.162	-0.337	-0.121	-0.168	-0.157	\	\	\
facade-C-NW	0.137	-0.064	-0.064	-0.184	-0.114	-0.118	-0.104	-0.123	\	\
facade-C-W	0.045	0.038	0.065	-0.181	-0.12	-0.156	-0.143	-0.138	-0.097	\
facade-C-SW	-0.095	-0.014	0.094	-0.167	-0.099	-0.137	-0.126	-0.179	-0.078	-0.093

a Matrix of correlation coefficients for façade area ratio per orientation of canteen (facade-C-orientation)

	C-heat	C-cool	C-light	hd-C-S	hd-C-SE	hd-C-E	hd-C-NE	hd-C-N	hd-C-NW	hd-C-W
C-cool	0.708	\	\	\	\	\	\	\	\	\
C-light	-0.721	-0.587	\	\	\	\	\	\	\	\
hd-C-S	0.026	0.356	-0.153	\	\	\	\	\	\	\
hd-C-SE	-0.007	0.103	0.019	-0.126	\	\	\	\	\	\
hd-C-E	0.015	0.05	0.02	-0.152	-0.042	\	\	\	\	\
hd-C-NE	0.044	0	-0.056	-0.027	-0.016	-0.019	\	\	\	\
hd-C-N	0.296	0.2	-0.092	0.17	-0.026	-0.033	-0.004	\	\	\
hd-C-NW	0.028	-0.015	-0.046	-0.03	-0.016	-0.021	-0.003	-0.005	\	\
hd-C-W	0.145	0.205	-0.024	-0.13	-0.038	-0.116	-0.018	-0.028	-0.007	\
hd-C-SW	-0.053	-0.017	0.11	-0.123	-0.074	-0.098	-0.017	-0.027	-0.018	-0.036

b Matrix of correlation coefficients for height to depth ratio per orientation of canteen (hd-C-orientation)

	C-heat	C-cool	C-light	floor-C-S	floor-C-SE	floor-C-E	floor-C-NE	floor-C-N	floor-C-NW	floor-C-W
C-cool	0.704	\	\	\	\	\	\	\	\	\
C-light	-0.728	-0.6	\	\	\	\	\	\	\	\
floor-C-S	-0.442	-0.172	0.271	\	\	\	\	\	\	\
floor-C-SE	0.141	0.467	-0.368	-0.168	\	\	\	\	\	\
floor-C-E	-0.211	-0.192	0.315	-0.204	-0.132	\	\	\	\	\
floor-C-NE	0.379	0.143	-0.313	-0.168	-0.108	-0.132	\	\	\	\
floor-C-N	-0.109	-0.299	0.143	-0.21	-0.135	-0.165	-0.135	\	\	\
floor-C-NW	0.468	0.112	-0.362	-0.17	-0.109	-0.133	-0.109	-0.137	\	\
floor-C-W	-0.178	-0.222	0.385	-0.194	-0.125	-0.153	-0.125	-0.157	-0.127	\
floor-C-SW	0.193	0.354	-0.305	-0.159	-0.102	-0.125	-0.102	-0.128	-0.104	-0.119

c Matrix of correlation coefficients for floor area ratio per orientation of canteen (floor-C-orientation)

FIG. 5.10 Matrix of correlation coefficients, between energy demands of canteen and all design indicators for canteen

Taking canteen as an example, which has one room in the layout, the matrixes of correlation coefficients between all design indicators of canteen and its energy demands are shown in Figure 5.10, in addition to the façade area to floor area ratio which is already shown in Figure 5.8-c.

Compared to the other three types of design indicators (Figure 5.10), ff-canteen-orientation (Figure 5.8-c) have much higher coefficients with energy demands of canteen. Although clear linearity is shown, some coefficients of ff-canteen-orientation are lower than 0.30. The low coefficients are because that in one layout canteen has one specific orientation, and the value of ff-ratio in the other orientations are zero, so this undermines the values of the coefficients. In conclusion, compared to the other three types of design indicators, ff-ratio has a higher influence on energy demands for each single room, as well as for the whole layout and for each function.

5.5 Optimisation for minimising energy demands

The computational method shown in Section 5.2 is used for the optimisation to minimise energy demands in this section. The outputs of heating, cooling and lighting demands for the layout are used for minimisation as the objectives for optimisation. The algorithm used for this optimisation is pilOPT [38], which is a multi-strategy proprietary algorithm and developed by ESTECO. This algorithm performs both global exploration and local refinement, depending on its artificial intelligence decisions based on the observed performance. Furthermore, it exploits the time availability during the design evaluation to train meta models that are used internally to define the strategy. PilOPT works well with moderate-to-heavy simulations due to its underlying artificial intelligence processes. With autonomous mode, it automatically defines the number of designs to be evaluated based on the information gathered during optimisation and stops once the Pareto frontier cannot be improved any further.

Two rounds of optimisation are run in total. In Section 5.5.1, the first round includes three single-objective optimisations for minimising heating, cooling and lighting demand respectively. In Section 5.5.2, the second round has one optimisation with the multiple objectives to minimise heating, cooling and lighting demands together. The 500 evaluations run for DOE are used to train meta models for each optimisation.

5.5.1 Single-objective optimisation for minimising each energy demand

Three optimisations are run with the following objectives respectively: minimising heating demand, minimising cooling demand, and minimising heating demand. The single-objective optimisation aims to investigate how much energy demands can be saved by changing space layout, and to find the layouts with the minimum energy demand in order to validate the conclusions on the relationships identified in Section 5.4. In addition to the optimisation results, the layouts with the minimum value of each energy demand are presented and discussed.

5.5.1.1 Results of the optimisations

The computational time for each optimisation and the resulting improvement in energy performance are shown in this section. The computational time of each optimisation is as follows:

- Regarding the optimisation for minimising heating demand, 297 evaluations (261 completed, 36 failed) are run and take 106 h 56 m, around 4.4 days.
- Regarding the optimisation for minimising cooling demand, 302 evaluations (280 completed, 22 failed) are run, and take 125 h 59 m, around 5.3 days.
- Regarding the optimisation for minimising lighting demand, 438 evaluations (371 completed, 67 failed) are run, and take 192 h 24 m, around 8 days.

The resulting improvement in each energy demand from the optimisations is shown in Table 5.8. The improvement (%) is calculated as dividing the difference between maximum demand and minimum demand by the maximum demand. It is found that changing function allocation, layout boundary and interior partition results in the improvement of 54% in lighting demand, 51% in heating demand, and 38% in cooling demand.

TABLE 5.8 The resulting improvement in each energy demand from single-objective optimisations

	Max demand (kWh/m ²)	Min demand (kWh/m ²)	Improvement (%)
Lighting demand	4.1	1.9	54%
Heating demand	28.1	13.8	51%
Cooling demand	5.5	3.4	38%

Note: These results are based on the energy demands of the layouts within the layouts satisfying the layout area constraint.

With the same simulation condition as shown in Section 5.2.3, our previous paper [39] compared the energy performance between 11 layouts, in which only function allocation was changed with a fixed layout boundary and interior partition. It was found that by only changing function allocation, the resulting improvement is 27% in lighting demand, 18% in heating demand and 11% in cooling demand [39]. Comparing the two cases, i.e. the one in which only function allocation is changed and the one in which layout boundary and interior partition are also changed, the later one results in higher improvement in energy demands.

5.5.1.2 Resulting layouts from the optimisation for minimising lighting demand

Among all layouts generated from the optimisation for minimising lighting demand which also satisfy the layout area constraint, the layout with the minimum lighting demand (1.9 kWh/m²), the layout with the maximum lighting demand (4.1 kWh/m²), and the layout with the moderate lighting demand (3.0 kWh/m²) are shown in Figure 5.11. By comparing the layout with the minimum demand with the other two layouts, the following conclusions are found:

- **The ff-ratio is relatively high in the layout with minimum lighting demand:** The ff-ratio of the layout with the minimum lighting demand is 0.71, while the ff-ratios of the other two layouts are 0.55 and 0.51 respectively. The layout with the minimum lighting demand has the highest facade area compared to other two layouts, in order to receive more daylight, and it results in a high ff-ratio. This is similar to the conclusions in Section 5.4.3.1.
- **Corner rooms have higher façade area than the other rooms in the layout with the minimum lighting demand:** In the layout with the minimum lighting demand, corner rooms have much higher façade areas than the other rooms, i.e. corner rooms have high ff-ratios. This is similar to the conclusions on the ff-orientation and energy demands in Section 5.4.4.

- **Offices are located in corner rooms in the layout with the minimum lighting demand:** In the layout with the minimum lighting demand, all corner rooms are used as offices, which have the highest lighting requirement than the other functions. Locating more important functions in corner rooms helps to save lighting demand, and this is similarly to the conclusions in Section 5.4.3.2.
- **Rooms in the North are more compact than the other orientations in the layout with the minimum lighting demand:** This is different from what Section 5.4.4 shows, i.e. negative correlation between ff-N and lighting demand. This is because that in order to reach a high ff-ratio for the layout and also keep the same layout area, the less important orientation (N) is compromised to reach better performance in the other more important orientations.

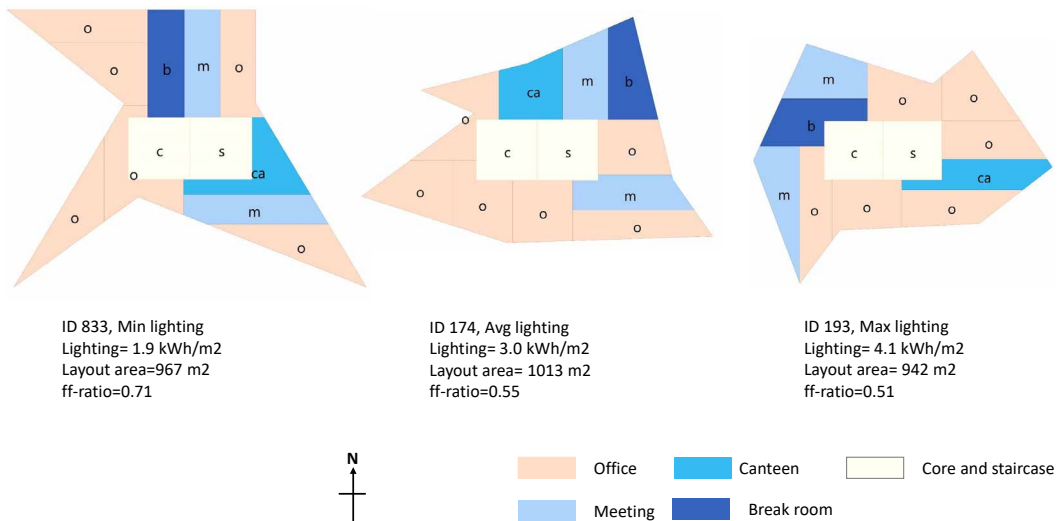

FIG. 5.11 The layout with the minimum lighting demand, the layout with the moderate lighting demand, and the layout with the maximum lighting demand, resulting from the optimisation for minimising lighting demand
 Note: ID is the number of designs in the optimisation.

5.5.1.3 Resulting layouts from the optimisation for minimising heating demand

Among all layouts generated from the optimisation for minimising heating demand which also satisfy the layout area constraint, the layout with the minimum heating demand (13.8 kWh/m²), the layout with the maximum heating demand (28.1 kWh/m²), and the layout with the moderate heating demand (21 kWh/m²) are shown in Figure 5.12. By comparing the layout with the minimum heating demand with the other two layouts, it is found that **the ff-ratio of the layout is relatively low**. The ff-ratio of the layout with the minimum heating demand is 0.4, while the ff-ratios of the other two layouts are 0.5 and 0.7 respectively. A smaller ff-ratio results in a smaller façade area, which causes less heat loss through façade. This is similar to the conclusions in Section 5.4.3.1.

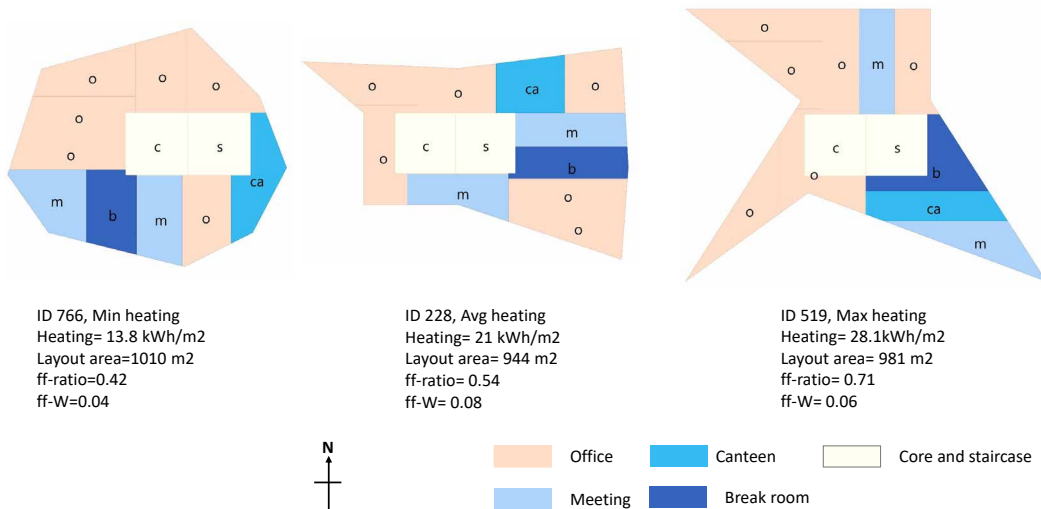

FIG. 5.12 The layout with the minimum heating demand, the layout with the moderate heating demand, and the layout with the maximum heating demand, resulting from the optimisation for minimising heating demand

There is a clear characteristic in the layout with the minimum heating demand: there is no room orienting East, for which the room orientations follow the orientation definition based on the normal of internal walls as Figure 5.5-a shows. In order to figure out the reason for this characteristic, the layouts which have no room orient West, satisfy the layout area constraint, and have a low ff-ratio (lower than 0.46 for a low heating demand), are selected for comparison with the layout with the minimum heating demand, in Figure 5.13.

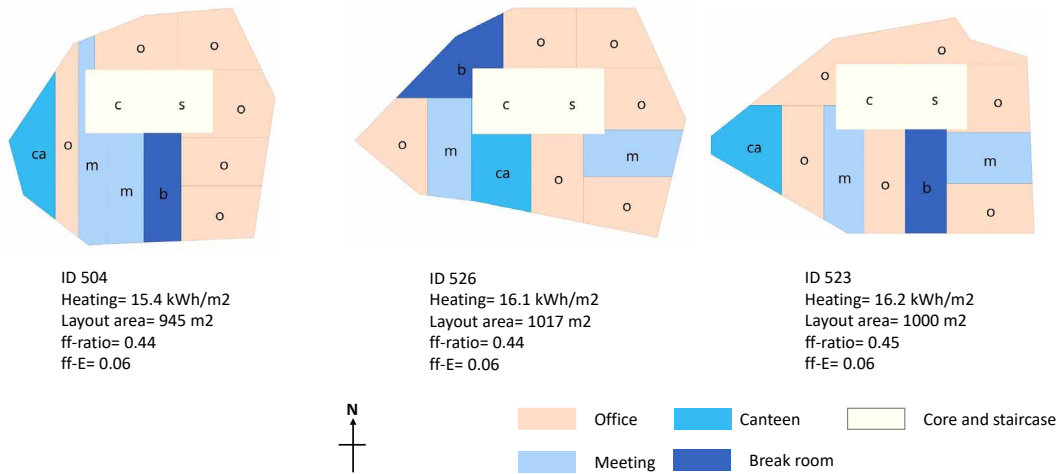

FIG. 5.13 Layouts in which no room orients the West and satisfy layout area constraint, resulting from the optimisation for minimising heating demand
Note: The room orientations follow the orientation definition based on the normal of internal walls as Figure 5.5-a shows

Regarding the influence on heating performance, the sequence of locations without corners from good to bad is: S > E/W > N. The three layouts in Figure 5.13 are used to be compared with the layout with the minimum heating demand (ID 766) shown in Figure 5.12. The east rooms in Figure 5.13 with ff-E of 0.06 are wider than the west rooms in ID 766 with ff-W of 0.04. The wider room results in a higher heating demand for layouts in Figure 5.13 than ID 766.

The reason for the wider room in Figure 5.13 is the way how layouts are generated as shown in Figure 5.3-d. The starting line to split the layout (Line-0) has a fixed location for every layout, and the first splitting line (Line-1) always orients North. Therefore, the NE corner room is always attached to Staircase. It results in less freedom for the locations of east rooms compared to west rooms. So, the layout with no room orienting East helps to reach the minimum heating demand in this case. It implies that the constraint on the location of internal walls results in the specific preference of room locations when optimising the layouts for minimising heating demand.

5.5.1.4 Resulting Layouts from the optimisation for minimising cooling demand

Among all layouts generated from the optimisation for minimising cooling demand which also satisfy the layout area constraint, the layout with the minimum cooling demand (3.4 kWh/m²), the layout with the maximum cooling demand (6.7 kWh/m²), and the layout with the moderate cooling demand (5.0 kWh/m²) are shown in Figure 5.14. By comparing the layout with the minimum cooling demand with the other two layouts, the following conclusions are found:

- **The ff-ratio of the layout with the minimum cooling demand is relatively low:** A low ff-ratio helps to reduce façade area and heat losses through façade as well. The situation is similar to the layout with the minimum heating demand.
- **More rooms orient N, E and W than S in the layout with the minimum cooling demand:** In this layout, only one room orients South, and it is used as break room, the function with the lowest requirement for cooling. Although a low ff-ratio in all orientations helps to reduce cooling demand, a compromise is needed to accommodate all rooms within a limited layout area. Locating less rooms in South helps to reduce the cooling demand of the whole layout.

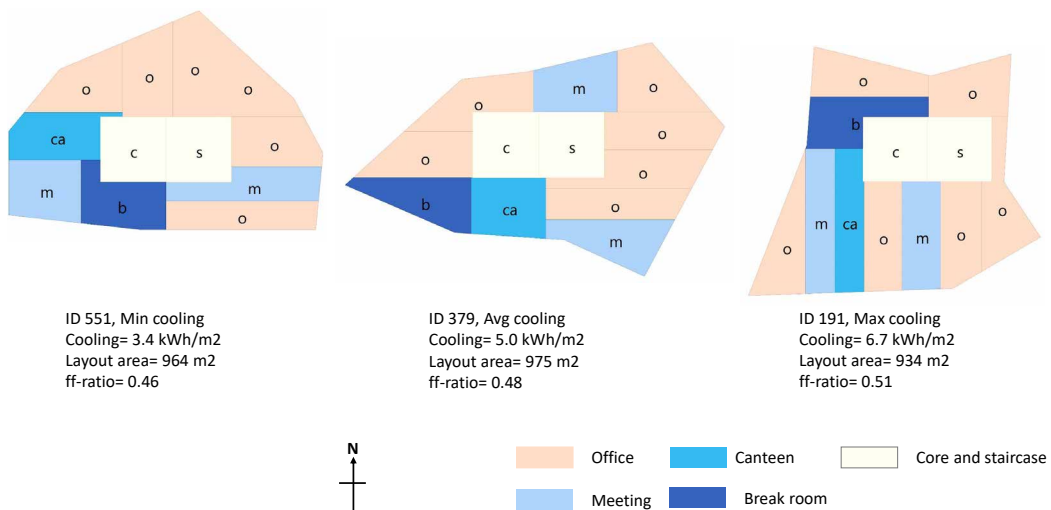
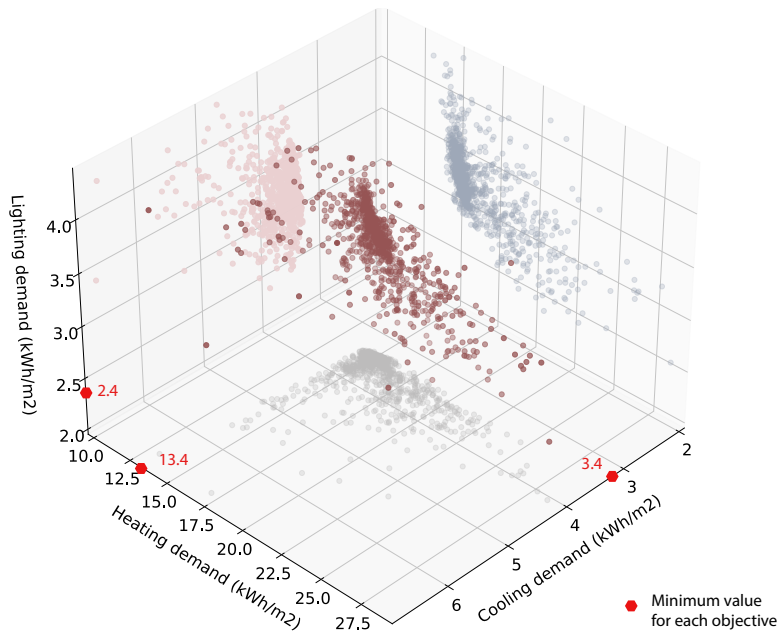

FIG. 5.14 The layout with the minimum cooling demand, the layout with the moderate cooling demand, and the layout with the maximum cooling demand, resulting from the optimisation for minimising cooling demand

5.5.2 Multi-objective optimisation for minimising all energy demands

The optimisation with the multiple objectives for minimising heating, cooling and lighting demands for the layout is run in this section. This optimisation aims to show how to apply the computational method developed in this study with multiple objectives and analyse the possible problems. In total, 1447 evaluations (1393 completed, 54 failed), among which 925 designs are feasible, i.e. the layouts satisfy the layout area constraint and their simulations were run successfully. The total computational time for the optimisation is 598 hours and 46 minutes, around 25 days. Based on the optimisation results, all feasible designs are shown in a 3D chart with the heating demand (kWh/m^2) as X axis, cooling demand (kWh/m^2) as Y axis, and lighting demand (kWh/m^2) as Z axis in Figure 5.15-a. The history charts for minimising lighting, heating and cooling demands are shown in Figure 5.15-b to 5.15-d respectively.

As shown in Figure 5.15, the resulting minimum lighting, heating and cooling demands from the multi-objective optimisation are 2.4 kWh/m^2 , 13.4 kWh/m^2 , and 3.4 kWh/m^2 respectively. In contrast, the resulting minimum demands from the single-objective optimisations as shown in Section 5.5.1 are 1.9 kWh/m^2 , 13.8 kWh/m^2 , and 3.4 kWh/m^2 respectively. The minimum lighting demand resulted from the multi-objective optimisation is much higher than the minimum lighting demand resulted from the single-objective optimisation. This means that the multi-objective optimisation needs a much longer time in order to find the minimum lighting demand similar to the single-objective optimisation. However, as shown in Figure 5.15-c and 5.15-d, the multi-optimisation takes a much shorter time to find the minimum heating and cooling demands which are similar to the result of single-objective optimisations. This is because the correlation between heating demand and cooling demand is positive, while the correlation between lighting demand and the thermal demands is negative. For instance, a compact layout, with a low ff-ratio, results in low heating and cooling demands, while a high lighting demand. It is the contradictory relationship between lighting demand and the thermal demands that makes the optimisation needs a much longer time to find the minimum lighting demand than heating and cooling demands.



a 3D chart for the three objectives, in which only the layouts satisfying the layout area constraint are shown

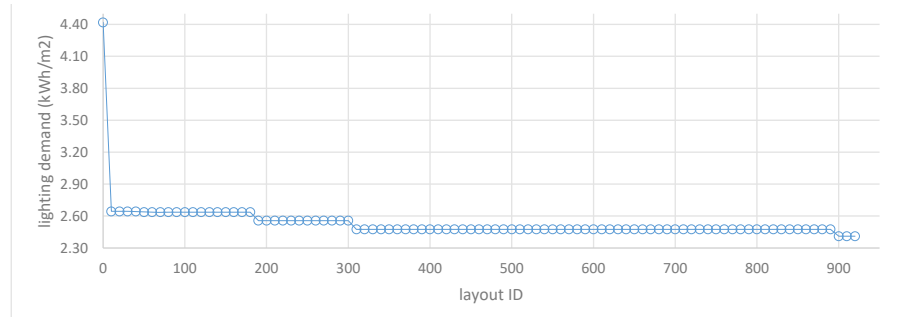

b History chart for minimising lighting demand

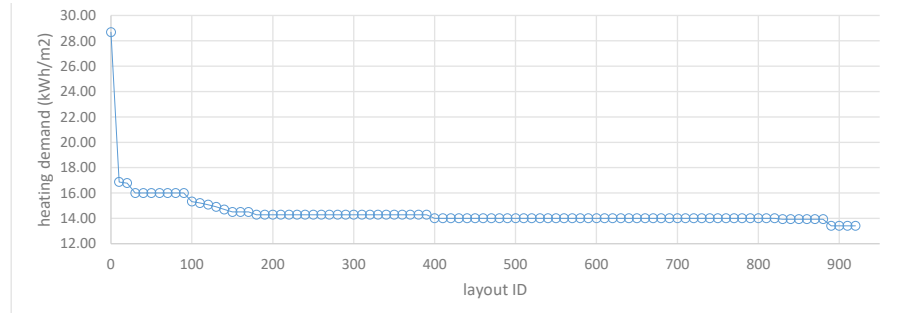

c History chart for minimising heating demand

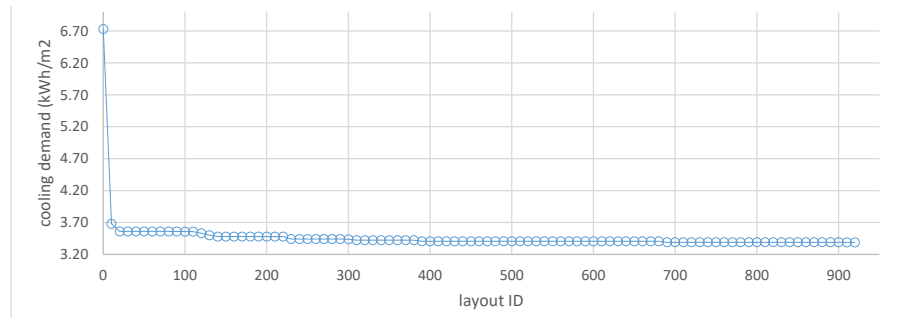

d History chart for minimising cooling demand

FIG. 5.15 3D chart and history charts for the three objectives of the multi-objective optimisation, with only feasible layouts (i.e. satisfying the layout area constraint)

Note: In order to better illustrate the optimisation process, only the minimal value of each 10 evaluations is shown in the history charts, i.e. Figure 5.15-b to 5.15-d

As for the resulting layouts from this optimisation, the best solution for minimising all energy demands cannot be directly extracted, as the three energy demands are conflicting as explained in Section 5.4.3.1, i.e. lighting demand has a negative relationship with thermal demands. However, designers can decide the best solution based on their own preference and also the specific requirements of the project, by defining their own criteria for choosing between different energy demands, like defining different weight factors for different energy demands. For instance, if the thermal demand of the project is dominant, designers can give higher weight factors to thermal demands and a lower weight factor to lighting demand. In this way, the best solution can be identified.

5.6 Conclusions and recommendations

This study develops a computational method to generate space layout and evaluate the energy performance of the generate layout for Amsterdam climate. Regarding space layout design, four types of design indicators are proposed for the whole layout as well as for each function. With the developed method, a DOE is run for 500 evaluations with energy demands and design indicators as outputs. Based on the results of DOE, the relationships between design indicators and energy demands are identified and analysed. With the same method, two rounds of optimisation for minimising heating, cooling and lighting demands are run. The first round includes three single-objective optimisations to minimise the three energy demands respectively. The second round includes one multi-objective optimisation to minimise all energy demands. Based on the results of each single-objective optimisation, the layouts with the minimum, maximum and moderate energy demand are found and the conclusions on relationship analysis are validated by comparing the layout with the minimum energy demand with the other layouts. The multi-objective optimisation shows how the developed method is applied for multiple objective problems.

5.6.1 Conclusions

The following conclusions regarding the relationships between design indicators and energy demands, which are simulated for a temperate climate, are found:

- A Comparing the four types of design indicators, ff-ratio shows stronger correlations with energy demands than façade area ratio, floor area ratio and height to depth ratio. For example, medium and high clear correlations are found between energy demands for the layout with ff-ratios in different orientations. However, no clear correlation is found with floor area ratio, façade area to floor area ratio, and height to depth ratio, as explained in Section 5.4.4.
- B Comparing different locations within the layout, corner rooms show stronger correlations with energy demands than the other locations. For example, comparing the ff-ratios in different orientations, the ff-ratios in corners show higher correlation coefficients with energy demands of the layout than the other rooms, as explained in Section 5.4.4.

- C Comparing different functions defined in this study, offices show strong correlations with the energy demands for the layout compared to the other functions, followed by meeting rooms, as explained in Section 5.4.3.2.
- D Comparing the design indicator of one function with multiple rooms and the indicator of the function per room, the correlation coefficient of the function with multiple rooms is compromised by the room number regarding its influence on the corresponding energy demand. For example, clear correlations are found between the ff-ratios for one office and the energy demand for this office, while no clear correlation is found between the ff-ratios for all offices (including 6 rooms) and the energy demands for all offices, as shown in Section 5.4.5.

The following conclusions regarding the optimisation results are found:

- A Designing space layouts with changed layout boundaries, function allocations and internal partitions saves more energy demands than only changing function allocations. This is found by comparing the resulting improvement of each single optimisation in this study with the results shown in our previous study of [23], in which only function allocation was tested for its effect on energy demands and much lower improvements were reached compared to this study.
- B The resulting layouts with the minimum energy demands from optimisation have proven the results and conclusions on the relationship analysis based on DOE.
- C There is a clear characteristic shown among the layouts with the minimum heating demand, while it cannot be found from the relationship analysis based on DOE results. Because the characteristic is caused by the method in which how space layouts are generated. It implies that a space layout design with constraints, like a fixed internal wall in the layout, would result in a specific prototype of layouts while chasing lower energy demands.
- D The optimisation for minimising lighting demand takes a much longer time than for minimising thermal demands, for both single-objective and multi-objective optimisation.

5.6.2 Recommendations

Based on the results and conclusions drawn in this study, the following recommendations are made for both designing energy-efficient space layout and future academic research regarding how to design space layout for minimising energy demands.

5.6.2.1 How to design energy-efficient space layout?

In order to help designers to design energy-efficient space layout, the conclusions are interpreted to the following recommendations:

- Designers can design a space layout by changing the ff-ratio in a temperate climate, which helps to find a layout with low energy demands quickly.
- Designers should pay attention to internal partitions for reducing energy demands in building design. Generally, the internal partition is considered at a quite late design phase. However, the internal partition determines the ff-ratio for each room, and the ratio is proven by this study to be highly influential on energy demands of buildings.
- Locating important functions in corner rooms helps to find the layout with minimal lighting demand in a temperate climate.
- The computational method is necessary to design space layout for minimising energy demands, since the design variables of space layout cannot be easily changed manually to satisfy the requirements (like room area) and the energy performance cannot be predicted directly.

5.6.2.2 Recommendations for future research

For future research the following recommendations are given regarding the generation of space layout, assessment of energy performance and optimisation of space layout design for minimising energy demands.

Different methods of generating space layout result in different characteristics of layouts with minimum energy demands. The following recommendations are made regarding the method of space layout generation developed in this study for future improvement:

- Changing the location of the starting line to split the layout: The location of the starting line results in a clear characteristic among the layouts with the minimum heating demand, i.e. no room locates in East. Thus, in the early design phase, no or less limitation of the starting line can result in more flexible variance in layout.
- Separating the locations of core and staircase: Core and staircase are adjacent to each other in this study, while they can be located in the opposite orientations in a layout.
- Adding more control points for changing layout boundary: Eight control points are used in this study, while more control points result in more freedom in layout boundary. However, more control points mean more design variables, which need more computational time.
- The method developed in this paper aims to identify the relationship between space layout and energy demands, so the layout is varied in order to obtain different values of design indicators which are considered to be influential on energy. However, the resulting layouts can be impractical as functional requirements are not considered. In order to apply the developed method in practice, the method shown in this paper should be further developed in order to obtain more regular floorplan layout and include other functional requirements, like adding linking spaces, adjacency, connections, and the maximum distance from fire exit.

Regarding the assessment of energy performance, the following recommendations for future research are made:

- Testing more climates, like cold and tropical climates: This study tests temperate climate. Different climates have the different dominant energy demand, like heating demand for cold climate and cooling demand for tropical climate. It is expected that the same function in different climates has different preference for location, orientation, and ff-ratio.
- Testing the other design parameters for their influence on the effect of space layout on energy demands, like WWR, thermal mass, facade properties (thermal properties of facade and optical property of glazing and shading device), shading control type, set-points for heating, cooling and lighting.
- Testing more functions with bigger difference in their comfort requirements: It is the difference in the thermal and visual comfort requirements between functions that makes changing function allocations in reducing energy demands meaningful. The bigger difference in comfort requirements between functions, the higher that space layout (e.g. function allocation) influences energy demands.

Regarding the optimisation of space layout design for minimising energy demands, the following recommendations are made:

- Reducing computational time for optimisation: With four computers run in parallel for computation in this study, the multi-objective optimisation still takes around 25 days in this study. The long computational time is the main obstacle for applying the optimisation method of space layout design for minimising energy demands to practice.
- Comparing different methods for optimisation regarding different design tasks: Concerning the design variables for the optimisation of space layout design, two types of methods can be used. One is optimising the layout boundary firstly and then optimising the other design variables; the other method is what this study does, i.e. optimising all design variables together. It is difficult to tell which one is better. The comparison between the two methods is necessary, in terms of the computational time and the resulting improvement in energy performance.

References

- [1] B. Ekici, C. Cubukcuoglu, M. Turrin, I.S. Sariyildiz, Performative computational architecture using swarm and evolutionary optimisation: A review, *Building and Environment*. 147 (2019) 356–371. <https://doi.org/10.1016/j.buildenv.2018.10.023>.
- [2] R. Evins, A review of computational optimisation methods applied to sustainable building design, *Renewable and Sustainable Energy Reviews*. 22 (2013) 230–245. <https://doi.org/10.1016/j.rser.2013.02.004>.
- [3] Design to Construction | AIA ETN. <https://www.aiaetn.org/find-an-architect/design-to-construction/>. Accessed: January 2020.
- [4] D. Lobos, D. Donath, The problem of space layout in architecture: A survey and reflections, *Arquitetura Revista*. 6 (2010) 136–161. <https://doi.org/10.4013/arq.2010.62.05>.
- [5] F. Musau, K. Steemers, Space Planning and Energy Efficiency in Office Buildings: The Role of Spatial and Temporal Diversity, *Architectural Science Review*. 51 (2008) 133–145. <https://doi.org/10.3763/asre.2008.5117>.
- [6] I.G. Dino, G. Üçoluk, Multiobjective Design Optimization of Building Space Layout, Energy, and Daylighting Performance, *Journal of Computing in Civil Engineering*. 31 (2017) 04017025. [https://doi.org/10.1061/\(ASCE\)CP.1943-5487.0000669](https://doi.org/10.1061/(ASCE)CP.1943-5487.0000669).
- [7] T. Du, S. Jansen, M. Turrin, A. Van Den Dobbelssteen, Impact of space layout on energy performance of office buildings coupling daylight with thermal simulation, in: *Proceedings of the 13th REHVA World Congress CLIMA*, Burcharest, Romania, 2019: pp. 1–8. <https://doi.org/https://doi.org/10.1051/e3sconf/201911103077>.
- [8] E. Rodrigues, A.R. Gaspar, Á. Gomes, Automated approach for design generation and thermal assessment of alternative floor plans, *Energy and Buildings*. 81 (2014) 170–181. <https://doi.org/10.1016/j.enbuild.2014.06.016>.
- [9] T. Du, S. Jansen, M. Turrin, A. van den Dobbelssteen, Effects of Architectural Space Layouts on Energy Performance: A Review, *Sustainability*. 12 (2020) 1829. <https://doi.org/10.3390/su12051829>.
- [10] C.B. de Souza, S. Alsaadani, Thermal zoning in speculative office buildings: discussing the connections between space layout and inside temperature control, in: *Proceedings of the 1st Building Simulation and Optimization Conference*, Loughborough, UK, 2012: pp. 417–424. <http://www.ibpsa.org/proceedings/BSO2012/6C1.pdf>. Accessed: April 2017.
- [11] H. Poirazis, Å. Blomsterberg, M. Wall, Energy simulations for glazed office buildings in Sweden, *Energy and Buildings*. 40 (2008) 1161–1170. <https://doi.org/10.1016/j.enbuild.2007.10.011>.
- [12] H. Yi, User-driven automation for optimal thermal-zone layout during space programming phases, *Architectural Science Review*. 59 (2016) 279–306. <https://doi.org/10.1080/00038628.2015.1021747>.
- [13] T. Du, M. Turrin, S. Jansen, A. Van Den Dobbelssteen, J. Fang, Gaps and requirements for automatic generation of space layouts with optimised energy performance, *Automation in Construction*. 116 (2020) 103132. <https://doi.org/10.1016/j.autcon.2020.103132>.
- [14] M. Cavazzuti, *Optimization Methods: From Theory to Design*, Springer, Berlin, Heidelberg, 2554. <https://doi.org/https://doi-org.tudelft.idm.oclc.org/10.1007/978-3-642-31187-1>.
- [15] Grasshopper Algorithmic Modeling for Rhino. <https://www.grasshopper3d.com/>. Accessed: October 2018.
- [16] Esteco, modeFRONTIER | www.esteco.com. <https://www.esteco.com/modefrontier>. Accessed: August 2020.
- [17] M. Wetter, Co-simulation of building energy and control systems with the Building Controls Virtual Test Bed, *Journal of Building Performance Simulation*. 4 (2011) 185–203. <https://doi.org/10.1080/19401493.2010.518631>.
- [18] Ladybug Tools. <https://www.grasshopper3d.com/group/ladybug>. Accessed: October 2018.
- [19] Shading Module: Engineering Reference-EnergyPlus. <https://bigladdersoftware.com/epx/docs/8-0/engineering-reference/page-034.html#solar-distribution>. Accessed: August 2020.
- [20] Daysim. <http://daysim.ning.com/>. Accessed: October 2018.
- [21] EnergyPlus, EnergyPlus. <https://energyplus.net/>. Accessed: January 2019.
- [22] G. Ramos, E. Ghisi, Analysis of daylight calculated using the EnergyPlus programme, *Renewable and Sustainable Energy Reviews*. 14 (2010) 1948–1958. <https://doi.org/10.1016/j.rser.2010.03.040>.
- [23] T. Du, S. Jansen, M. Turrin, A. van den Dobbelssteen, Effect of space layouts on the energy performance of office buildings in three climates, *Journal of Building Engineering*. (2021). <https://doi.org/10.1007/bf02527095>.

- [24] L. Itard, Energy in the Built Environment, in: E. van Bueren, H. van Bohemen, L. Itard, H. Visscher (Eds.), Sustainable Urban Environments, Springer, Dordrecht, 2012: pp. 113–175. <https://doi.org/10.1007/978-94-007-1294-2>.
- [25] Netherlands Standardization Institute, NEN-16798-1 Energy performance of buildings - Part 1: Indoor environmental input parameters for design and assessment of energy performance of buildings addressing indoor air quality, thermal environment, lighting and acoustics - Module M1-6, 2015. <https://connect.nen.nl/Standard/Detail/207600?compId=10037&collectionId=0>. Accessed: March 2018.
- [26] M. Deru, K. Field, D. Studer, K. Benne, B. Griffith, P. Torcellini, B. Liu, M. Halverson, D. Winiarski, M. Rosenberg, M. Yazdani, J. Huang, D. Crawley, U.S. Department of Energy Commercial Reference Building Models of the National Building Stock, 2011. <https://doi.org/10.2172/1009264>.
- [27] H.M. Nieman, SBR-referentiedetails woningbouw 2015 Studenteneditie, Foundation Isso, Rotterdam, the Netherlands, 2015.
- [28] Bouwbesluit, Artikel 5.3. Thermische isolatie | BRIS Bouwbesluit Online. <https://www.bouwbesluitonline.nl/Inhoud/docs/wet/bb2012/hfd5/afd5-1/art5-3>. Accessed: June 2018.
- [29] Windows for High-performance Commercial Buildings. <https://www.commercialwindows.org/>. Accessed: November 2019.
- [30] SETTING RENDERING OPTIONS. https://floyd.lbl.gov/radiance/refer/Notes/rpict_options.html. Accessed: July 2019.
- [31] U.T. Aksoy, M. Inalli, Impacts of some building passive design parameters on heating demand for a cold region, Building and Environment. 41 (2006) 1742–1754. <https://doi.org/10.1016/j.buildenv.2005.07.011>.
- [32] E. Bostancıoğlu, Effect of building shape on a residential building's construction, energy and life cycle costs, Architectural Science Review. 53 (2010) 441–467. <https://doi.org/10.3763/asre.2009.0040>.
- [33] R. Gonzalo, K.J. Habermann, Energy-Efficient Architecture: Basics for Planning and Construction. https://books.google.nl/books?hl=zh-CN&lr=&id=6bhB8Tt3T4EC&oi=fnd&pg=PA5&dq=Energy-Efficient+Architect-+ture:+Basics+for+Planning+and+Construction.&ots=JrfkqWu8ZL&sig=czzxCE7I16WtJ6WwE1NX04WuMK0&redir_esc=y#v=onepage&q=Energy-Efficient+Architect-+ture%3A+Ba. Accessed: October 2020.
- [34] M.D. McKay, R.J. Beckman, W.J. Conover, A comparison of three methods for selecting values of input variables in the analysis of output from a computer code, Technometrics. 42 (2000) 55–61. <https://doi.org/10.1080/00401706.2000.10485979>.
- [35] & C. Benesty, J., Chen, J., Huang, Y., Pearson Correlation Coefficient, in: Noise Reduction in Speech Processing, Springer, Berlin, Heidelberg, 2009: pp. 1–4. https://doi.org/10.1007/978-1-4419-9863-7_372.
- [36] A. Field, Discovering statistics using SPSS, 2008. https://doi.org/10.1007/978-0-387-68969-2_13.
- [37] Statistics Solutions, Correlation (Pearson, Kendall, Spearman) - Statistics Solutions. <https://www.statisticssolutions.com/correlation-pearson-kendall-spearman/>. Accessed: January 2021.
- [38] Optimization Algorithms | www.esteco.com. <https://www.esteco.com/technology/optimization-algorithms>. Accessed: January 2021.
- [39] A. van den Dobbelaars, T. Du, S. Jansen, M. Turrin, Effect of space layouts on the energy performance of office buildings in three climates (under review), Journal of Building Engineering. (2021).

6 Design Recommendations for Energy-Efficient Space Layout

6.1 Introduction

Based on the research presented in the previous chapters, this chapter aims to translate the conclusions of the former chapters into recommendations for designers regarding energy-efficient space layout. In this thesis, space layout is defined as the allocation of different functions within a building, which includes interior layouts and placement of interior walls. It is also affected by the boundaries, shape or geometry of the building.

TABLE 6.1 Classification of building design parameters affecting BEP, regarding their relationships with space layouts

Design variables of space layout (with a non-fixed boundary)		Space properties		Envelope design
Space layout design (within a fixed boundary)		Functional requirements	Use of spaces	
<ul style="list-style-type: none"> – Space location – Space dimension – Space form – Interior partitions – Space orientation 	<ul style="list-style-type: none"> – Boundary dimension – Boundary form – Orientation 	<ul style="list-style-type: none"> – Heating set-point – Cooling set-point – Required lighting level – Required ventilation 	<ul style="list-style-type: none"> – Occupancy density and schedules – Equipment gains and schedules – Control strategies 	<ul style="list-style-type: none"> – Insulation – Window area – Window location – Glazing type – Shading type – Air tightness

As shown in Chapter 2, various design parameters related to space layout design influence the building energy performance (BEP). These parameters are listed in Table 6.1 and classified according to their relationship with space layout. The classification is made into four categories:

- The design variables directly related to the space layout design, given a non-fixed boundary;
- A sub-category of the first category is the design variables related to the space layout design within a fixed boundary;
- The space properties related to the functional requirements and use of spaces. These properties are very important for the energy performance, but these are actually not design variables, as they are requirements of the conditions related to the function of the space. Therefore they are shown in grey in Table 6.1;
- The properties of the building envelope.

This chapter aims to give recommendations for designers. As the space properties are considered fixed for each case, which cannot be changed by designers, the recommendations are given regarding the other three categories of design parameters. The recommendations are presented in the following structure:

- Section 6.2 gives general recommendations.
- Section 6.3 is on the function allocation, i.e. space location, which also determines the space orientation;
- Section 6.4 is on the partition between rooms, i.e. interior partition, which also influences the space form and dimensions;
- Section 6.5 is on the optimisation of space layouts together with building geometry, which includes boundary dimension, boundary form, and orientation;
- Section 6.6 is on the optimisation of space layouts together with the building envelope;
- In addition, Section 6.7 and 6.8 discuss the influence of different climates and HVAC efficiency on the effect of space layouts on overall energy performance.

These design recommendations are not only suitable for office buildings. As long as a building has multiple functions with different requirements for lighting, heating and cooling, the recommendations discussed in the following sections are applicable.

6.2 General recommendations

This research presented in this dissertation has shown that the optimising space layout for energy performance is very complex. Very few straightforward or general guidelines or design principles can be given, as the optimal space layout depends on many parameters, which means that the optimal space layout is too complex to predict. As shown in the conclusion of Chapter 3 and also explained in Chapter 3, it is not easy to predict which layout – given a number of manually designed variants – has the best energy performance. Furthermore, the results of this study are relevant to the specific cases shown in this study. If the space properties of the cases studied change, the optimal layout will be different. Hence, as the main recommendation, it can be stated that for optimising the layout of a specific case, an optimisation method similar to the one applied in Chapter 5 is recommended.

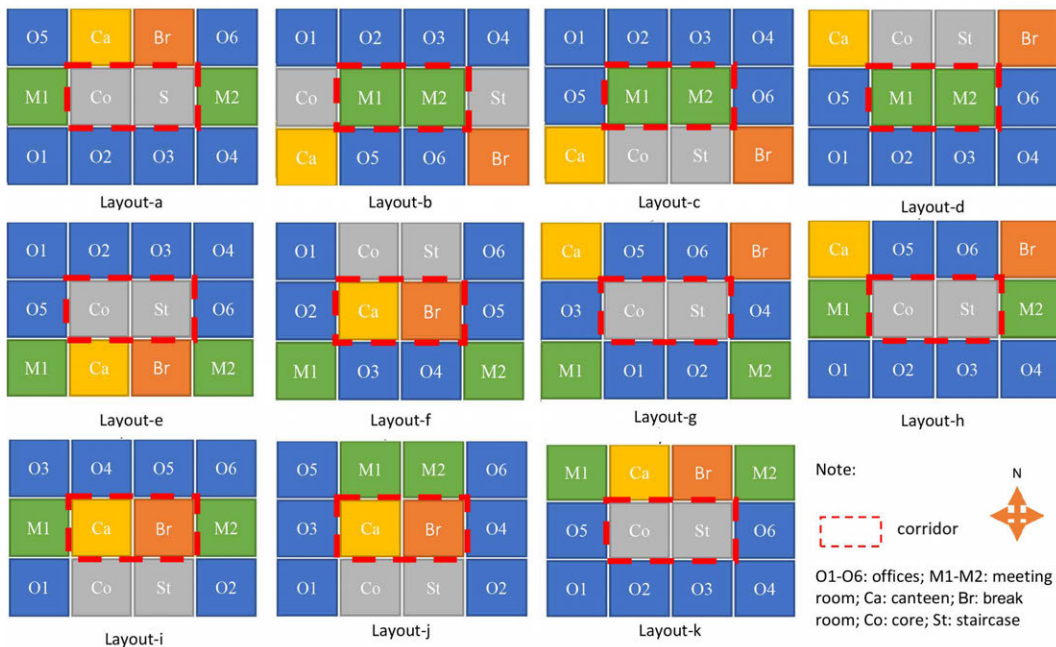

FIG. 6.1 11 layouts tested in Chapter 3

For the optimisation design, the number of design variables chosen from the list shown in Figure 6.1 depends on the level of design freedom. For instance, an existing building has fixed boundaries and possibly fixed internal partitions too, while a new building has many variable parameters. For a design with more freedom, including geometry and envelope design, a design for optimal energy performance is even more complicated. Therefore, an optimisation method that can deal with this complexity is essential if space layout design includes a high level of freedom.

As shown in Chapter 5, the computational optimisation method helps to find the optimal solution, by varying different design variables and calculating the energy performance of numerous possible solutions, which is too time-consuming to be done manually. The variables that can be changed and the function properties required for the simulation are shown in the introduction of this chapter.

6.3 Function allocation

6.3.1 Potential effect

Chapter 3 investigated the influence of space layout on three energy demands: heating, cooling and lighting. As the conclusions of Chapter 3 show, the function allocation affects all these energy demands, especially lighting demand.

The study was done for 11 layouts, as shown in Figure 6.1, with the same layout boundaries and a constant window-to-wall ratio (WWR) of 40%, only changing the function allocation. It shows that the maximum difference between highest and lowest demand² between these 11 layouts varies for the different energy demand types. The maximum difference in lighting demand is the highest, as high as 46% for layouts without shading and 35% for layouts with shading in Harbin. The maximum difference in heating demand is lower, i.e. 11% for layouts without shading and 18% for layouts with shading in Amsterdam. The maximum difference in cooling demand is the lowest, and the highest value is 8% for layouts without shading and 11% for layouts with shading in Amsterdam.

6.3.2 Theoretical explanation of the effect

Within one layout, some locations receive more daylight and solar gains than others, which results in a lower lighting and heating demand and potentially a higher cooling demand. Also with poor insulation the façade area influences the thermal demand. Different functions have different needs for heating, cooling and lighting because of the different set-points, as well as the different schedules of internal gains and ventilation. In some cases, specific functions can benefit from a certain orientation. For example, rooms that are used only in the morning may benefit from a location with an East orientation. Placing each function in the best location, where it can benefit the most, will help to reduce energy demand. However, this research shows that the best locations are often the best for all, or at least for many functions.

² The maximum difference (%) is calculated by dividing the difference between the highest and lowest resulting energy demand by the highest demand.

Corners, for instance, are best for all functions in terms of reducing lighting demand. In that case, the space layout with the highest energy performance is the layout where the functions that benefit most from the best locations are placed at these best locations. This can be seen as the ‘battle for the best location.’ which is explained in Chapter 3.

6.3.3 Recommendations

The right function allocation helps to improve building energy performance. However, it is not easy to give general recommendations as the ‘battle for the best location’ depends on many parameters, including space properties. Hence, the best space layout is very difficult to predict – or even impossible without energy simulations – and in addition, with different conditions or space properties, the conclusions are different. However, some general recommendations regarding function allocation can be given as follows:

- For minimising lighting demand, placing the function with highest lighting requirements (highest value and most often used) in a location with the largest façade area, which receives the most daylight, such as corner rooms in this research.
- It is difficult to give recommendations for thermal demand. The thermal demand depends on the difference between the available solar gains and the energy transmission through façades which differs between climates. As shown in Chapter 3, there is no big difference in cooling demand between the 11 layouts in Singapore. So, this is not discussed. However, in Amsterdam and Harbin (temperate and cold climate), the middle and South-oriented spaces are always the best locations for heating; the middle and North-oriented spaces are always the best location for cooling. So, in the temperate and cold climates, locating the function with high heating requirements, such as meeting rooms and offices, in the middle or South side of the building helps to reduce the heating demand; locating the function with high cooling requirements in the middle or North side helps to reduce the cooling demand.

6.4 Internal partitions between rooms

6.4.1 Potential effect

Chapter 5 discussed a design optimisation for space layout, in which the layout boundaries, internal partitions, and function allocation were changed. In order to analyse the relationship between space layout and energy performance, four types of design indicators of space layouts were proposed: the floor area ratio, façade area ratio, façade area to floor area ratio (ff-ratio), and height to depth ratio. These were investigated both at the total layout level and at function level.

The results of Chapter 5 show clear correlations between the ff-ratio and all energy demands, for the layout and for each function, especially in corners. For instance, the Pearson correlation between ff-SE³ and the heating demand of the layout is 0.7. This means that in a temperate climate, the layout with a high ff-ratio has a lower lighting demand, and a layout with a low ff-ratio has a lower heating and cooling demand, as shown in Figure 6.2. The ff-ratio of each room is determined by the internal partition. So, it is indicated that the internal partition between rooms influences energy performance highly.

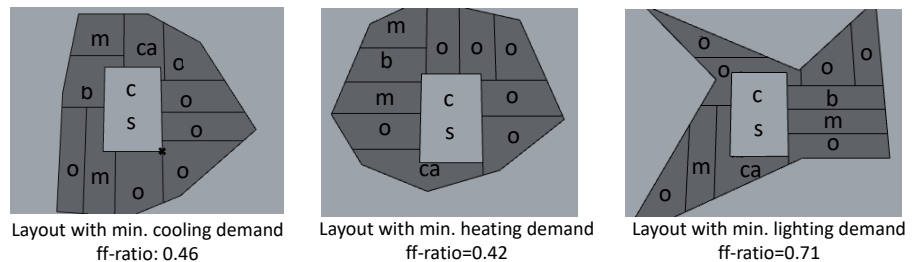

FIG. 6.2 The layouts with the minimum cooling, heating and lighting demand, resulting from the single-objective optimisations in Chapter 5

³ Ff-SE: façade area to floor area ratio in Southeast for the layout.

6.4.2 Theoretical explanation of the effect

The reasons for the influence of internal partitions on energy performance are as follows. On the one hand, this is because the internal partition determines the shape of rooms and how much rooms are facing a certain orientation: if one layout is partitioned and has more rooms facing South in Amsterdam, the layout will need less electric lighting; if one layout is partitioned with more rooms facing North, the layout will need more electric lighting. On the other hand, this is because the internal partition determines the shape of each room, which influences the amount of available energy in one room, as well as the distribution of the available energy. For instance, a deep room has a relatively small window, so it has a smaller quantity of solar gains and less heat transmission through the façade, and the deep part of the room receives much less daylighting and needs more electric lighting.

6.4.3 Recommendations

Considering the internal partition as one important design factor and including it in the early design phase helps to reduce the energy demand. However, in practice, designers or building owners generally leave the internal partitions to a late design phase, which gives less freedom for the change of internal partition. Therefore, in order to design a high energy performance building, it is important to draw the attention of designers and owners to the internal partitions between rooms. The energy performance of the whole building will benefit more if the internal partition is included as a design variable in the early design phase. In addition, for minimal heating and cooling demands, the layout should have a lower ff-ratio; for minimising lighting demand, the layout should have a higher ff-ratio.

6.5 On optimisation of space layouts together with building geometry

In precedents (see literature review) on optimisation design for the improvement of the building energy performance, the building geometry and layout boundary are mostly determined first, followed by the internal partitions, function allocation and room forms, i.e. the design variables of space layout within fixed boundaries. However, in this way, the optimisation of the geometry is done using one function's energy requirements or the average requirements over different functions. So, the difference in energy requirements between different functions is ignored in this phase, and the ability of space layout to save energy consumption is reduced. Integrating space layout optimisation design with geometry design (i.e. varying the design variables of space layouts with non-fixed boundaries) can allow identifying design solutions that save more energy compared to the optimisation design for only space layout or only geometry. So, **if possible, combine geometry design with space layout design to pursue higher energy saving.**

6.6 On optimisation of space layout together with the building envelope

The influence of the WWR and U value on the effect of space layout on energy performance was investigated in Chapter 3. The sensitivity analysis indicates that design variables of envelopes, such as the WWR, influence the effect of space layouts on energy performance. For instance, the maximum difference in lighting demand between the 11 layouts with shading in Harbin is 25% for the WWR of 20% and is 55% for the WWR of 60%. Regarding the relationship with envelope design, this research indicates two methods of optimisation of space layouts. One is that if the envelope properties are fixed, the design variables of space layout are varied without changing the envelope properties, as in the work presented in Chapter 5. The other method is combining space layout design with envelope design, i.e. varying the design variables of space layout and the ones of envelopes together for one optimisation. In this way, the difference between different locations in available

energy, such as daylight and solar gains, is enlarged. It is expected that the energy performance of the whole building would be improved more, compared to the optimisation of space layout without changing envelope properties. So, **if possible, design space layout together with varied design variables of envelopes.**

6.7 On optimisation of space layouts when including functional requirements

The computational method developed in Chapter 5 mainly addresses the optimisation for energy – on a theoretical understanding. However, as for the practical application of the optimisation results for designers, the functional requirements need to be added to this method, either in the computational workflow prior to optimisation or the designers would use the energy optimisation outcomes as concept sketch to compare.

As for how to implement the optimisation method for energy (in Chapter 5) with functional requirements, designers can follow the two methodologies shown in Section 4.2.1. The difference between the two methodologies is as follows: in the first method, functionality is optimised first and then energy performance is optimised; in the second method, functionality and energy performance are optimised as the same time.

TABLE 6.2 Requirement for layout functionality

Topological requirement	Geometric requirement
Space connection	Width, length and height of space
Space adjacency	Width, length and height of boundary
Space separation	Space area
Orientation preference	Layout area
	Space compactness
	Boundary compactness
	Non-overlap
	Non-overflow

With emphasis on the time required for energy simulations, the following recommendation is given regarding which one of the two methodologies shown in Section 4.2.1 should be used. If the energy simulations allow a fast assessment (e.g. via simplified calculations, surrogate models, or other methods to reduce computational burden), then the second methodology shown in Section 4.2.1 is recommended, i.e. the functional requirements can be implemented together with energy optimisation, as objectives or (parametric) rules and constraints. Otherwise, the first methodology shown in Section 4.2.1 is recommended, i.e. functional requirements are optimised first and then energy performance is optimised consequently.

6.8 Designing for different climates

6.8.1 Potential effect

In Chapter 3, the effect of space layout on the energy performance was investigated in three climates, i.e. temperate, cold and tropical. According to the results in Chapter 3, the effect of space layout on different energy demands differs between the three climates. In Chapter 3, only function allocation was varied, while keeping all other design variables of space layouts constant. As shown in Chapter 3, comparing the three energy demands, the lighting demand is influenced most by function allocation in all three climates. The maximum difference in lighting demand is as high as 46% for layouts without shading and 35% for layouts with shading.

Regarding the thermal demand, the influence of function allocation differs between climates. Figure 6.3 shows the biggest maximum differences in heating and cooling demands caused by function allocation for the three climates, resulting from Chapter 3. Based on the figure, the following effects on the thermal demands in the three climates can be found.

- In Amsterdam, the maximum difference in the thermal demand is greater than 9% for layouts both with and without shading. So, the influence of function allocation on thermal demands in the temperate climate should be considered for layouts both with and without shading.

- In Harbin, the maximum differences in the thermal demand for layouts with shading are greater than 9%. However, the maximum difference for layouts without shading is smaller than 4%. So, the influence of function allocation on the thermal demand in the cold climate should be considered for layouts with shading.
- In Singapore, the maximum difference in the thermal demands is smaller than 4% for layouts both with and without shading. So, the influence of function allocation on thermal demands in the tropical climate can be ignored for layouts both with and without shading.

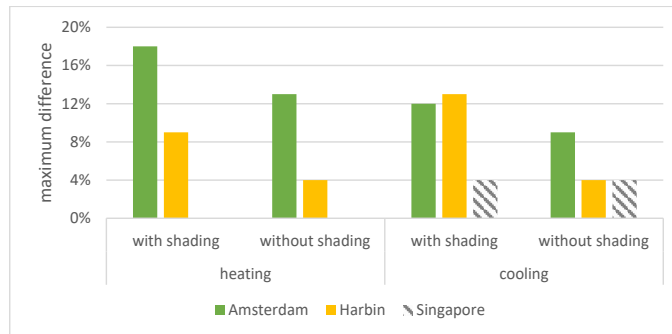

FIG. 6.3 The biggest maximum differences in heating and cooling demands caused by function allocation for the three climates shown in Chapter 3

6.8.2 Theoretical explanation of the effect

The relative difference in thermal demand is influenced less by function allocation in the cold and tropical climates than in the temperate climate. This is caused by the fact that the absolute thermal demand in cold and tropical climates is much higher than in the temperate climate, and it makes the difference caused by function allocation less important. For example, the absolute maximum difference (kWh/m^2) between the 11 layouts is $3.1 \text{ kWh}/\text{m}^2$ for Amsterdam and $3.5 \text{ kWh}/\text{m}^2$ for Harbin, while the maximum heating demand among the 11 layouts is $17.6 \text{ kWh}/\text{m}^2$ for Amsterdam and $41.4 \text{ kWh}/\text{m}^2$ for Harbin. So the relative maximum difference (%) is 18% for Amsterdam and only 9% for Harbin. This implies that the influence of design variables of space layouts can be different in different climates, and that it is important to also look at the absolute values.

6.8.3 Recommendations

In conclusion, the impact of space layout on different energy demands in one climate needs to be identified before applying it to improve the energy performance. Since this research only tested the influence of function allocation in different climates, only the following recommendations for function allocation can be drawn:

- In all three climates, the influence of function allocation can be considered for improving the lighting performance of layouts both with and without shading.
- In a temperate climate, the function allocation also impacts the thermal performance for layouts both with and without shading.
- In a cold climate, the function allocation can be considered for improving the thermal performance of layouts with shading.
- In a tropical climate, the influence of function allocation on thermal performance is negligible.

6.9 Optimisation when taking into account energy system efficiency

6.9.1 Potential effect

As explained in Section 6.3 and 6.4, the energy demand for heating, cooling and lighting is influenced by space layout design. The final energy consumption of the building is also determined by the energy system supplying these demands, i.e. the HVAC for heating and cooling, and the system for lighting.

If the final energy consumption is considered for the optimal layout, the energy efficiency of the technical systems supplying different energy demands (heating, cooling and lighting) plays a role. The final energy consumption is depending on the absolute value of each demand and on the efficiency of the systems supplying each demand. This means that the optimisation result varies for different energy systems.

In Chapter 3, the effect of space layout on the sum of final energy for heating, cooling and lighting was also analysed. An air-source heat pump was assumed to be used for heating and cooling. The resulting maximum difference in final energy differs from the maximum difference in energy demands. For instance, although the maximum difference is as high as 27% in lighting demand and 18% in heating demand and 11% in cooling demand between the 11 layouts with shading in Amsterdam, the maximum difference in the final energy is only 8%.

6.9.2 Theoretical explanation of the effect

The reason why the maximum difference in final energy is different and more likely smaller than within the separate demands, is twofold: firstly, the best layout for one demand is not the same for all demands, because some locations within one layout are better for heating or cooling while others for lighting. Especially heating and cooling often have the opposite 'best' locations. For instance, the South side is better for heating while the North side is better for cooling. Secondly, one certain energy demand might be dominant over the other energy demands, such as the heating demand in the cold climate and cooling demand in the tropical climate. So,

in this research, although the maximum difference in lighting demand is as high as 27%, the maximum difference in final energy is only 8%. This is because lighting constitutes a much smaller proportion of the final energy compared to the thermal demand. If the energy efficiency for supplying the dominant energy demand is very high, the influence of this demand on minimising the final energy consumption becomes smaller; however, if the energy efficiency of the dominant energy demand is very low, the relative influence becomes even bigger. Therefore, the energy efficiency of the heating, cooling and lighting system also plays a role in finding the optimal layout for minimising final energy. This can be considered when optimising the total layout.

6.9.3 Recommendation

If the aim of the optimisation design of space layout is to minimise the final energy consumption, defining different energy efficiencies for different energy demands is needed. Additionally, although lighting constitutes a much smaller proportion of the whole final energy in this research, the lighting demand is highly relevant to and determined based on the daylighting performance. The daylighting performance is influential on the visual comfort of occupants, in terms of daylight availability and glare possibility. In practice, the visual comfort should also be considered in addition to minimising the final energy. If the visual comfort and final energy is considered in finding the optimal layout, the lighting performance is more influential than what is shown in this research.

7 Conclusions

7.1 Introduction

The research presented in this dissertation aimed to investigate how space layout affects energy performance, and to develop a computational method for the optimisation of space layout to improve the building energy performance (BEP) of office buildings.

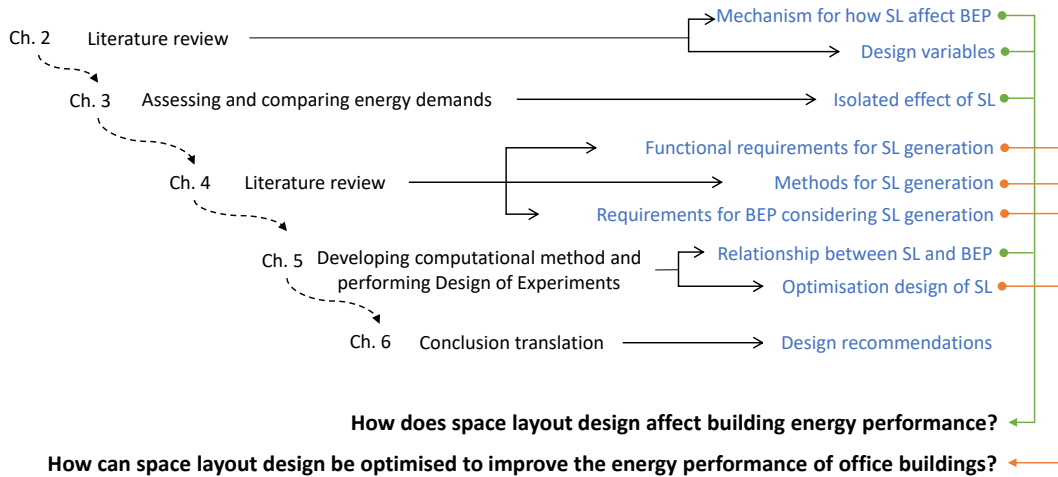

FIG. 7.1 Main studies of the research

Note: SL: space layout, BEP: building energy performance.

As shown in Figure 7.1, five studies were conducted: (1) literature review on how space layout affects the BEP and design variables of space layout; (2) assessing and comparing energy demands to identify the isolated effect of space layout; (3) literature review on the requirements for the automatic generation of space layout

and energy performance optimisation; (4) developing a computational method to optimise space layout and perform Design of Experiments, leading to the analysis of and insight into the relationship between space layout and BEP; (5) translating the conclusions into design recommendations.

This chapter presents the general conclusions drawn from this PhD research. First, in Section 7.2, the answers to the research sub-questions are given, which lead to a comprehensive answer to the main research question of the research. Then, in Section 7.3, general conclusions are drawn, including the main important findings and contributions. Next, in Section 7.4, the limitations and recommendations for future development are discussed. Lastly, in Section 7.5, a brief outlook is formulated.

7.2 Answers to the research questions

7.2.1 Sub-questions

7.2.1.1 How does space layout affect building energy performance and what are the relevant parameters, based on current research? (Ch. 2)

Regarding this research question, a literature review was conducted in Chapter 2. The studies relevant to space layout and energy performance were collected. It was found that many studies on each topic can be found, but only a few studies combined both.

Based on the review of the references collected, three topics were studied and conclusions were drawn: (1) the mechanism was identified how space layout affects the BEP; (2) the design variables that affect BEP were identified and classified; (3) based on the relatively small number of papers that combined energy performance and space layout, a first investigation of the effect on space layout was concluded. The conclusions on these three topics are briefly summarised below.

As the first step to explore how space layout affects energy performance, it is found that the following factors play a role. Different functions have different characteristics, including different occupancy (i.e. internal heat gains) and comfort requirements (temperature and lighting set-points, as well as ventilation requirements), while at the same time different locations in a space layout have different availability of daylight and natural ventilation. The combination of function properties and location determines the energy required for heating, cooling, lighting and ventilation in one location; the different function properties thus lead to the possibility to optimise the location of each function to improve the BEP. In addition, different space layouts are suitable for different types of control of space heating, space cooling, ventilation and lighting systems.

The design variables affecting the BEP were also identified, and they were classified according to their relationships with space layout. The design variables were classified into the following categories: (1) design variables of space layout with non-fixed boundaries; (2) as a sub-category of the first category, design variables of space layout within fixed boundaries; (3) space properties related to the functional requirements and use of spaces; (4) properties of the building envelope.

In addition, the effect of space layout on the BEP was also explored informed by the review. The review shows that space layout is influential on both energy use and occupant comfort. The energy use includes the ones for heating, cooling, lighting and ventilation. Occupancy comfort includes thermal and visual comfort. For instance, the reductions in heating and cooling demands on peak days caused by space layout were up to 57% and 11% respectively, for an office building in the UK. The resulting approximate reduction in predicted mean vote (PMV) was around 13% for an office building in South Korea.

Lastly, this review showed the following research gaps. Most of the reviewed studies mixed space layout with other design parameters, such as window-to-wall ratio (WWR), which makes it very difficult to identify the isolated effect of space layout. Different studies used different energy indicators, in terms of energy end-use, assessment period, and system boundaries, which makes it difficult to compare results between different studies. These reviewed studies not always consider the influence of daylighting on the assessment of energy demands, i.e. integrating the assessment of daylight performance with energy performance. Therefore, the effect of space layout on energy demand was not fully analysed.

7.2.1.2 What is the isolated effect of space layout on building energy performance? (Ch. 3)

In order to identify the isolated effect of space layout, in Chapter 3, 11 layouts with different function allocations were proposed, keeping the same layout boundaries and internal partitions. An assessment method was developed integrating daylight simulation with energy simulation for heating and cooling, and the performance indicators were determined. Both annual energy demands (heating, cooling and lighting) and final energy performance of the different layouts were simulated and compared for three climates, i.e. temperate, cold and tropical climate. Furthermore, the situations with and without a shading system were simulated for each layout.

The properties of external walls, windows and floor in terms of U values and glazing properties were based on different local regulations or common use of the three typical cities for the three climates. The variables depending on the function of rooms, like ventilation rate, set-points for heating, cooling and lighting, internal gains for people and equipment, and occupancy schedule, were based on the functional requirements and used per function. These were kept the same for the three climates.

The main finding is that space layout design – even within fixed boundaries, i.e. changing function allocation, can reduce energy demands significantly, especially lighting demand. Additionally, the effect of function allocation on the energy performance differs between climates. The effect is the highest in a temperate climate and the lowest in a tropical climate. The effect was measured as a relative difference, i.e. maximum difference, calculated by dividing the difference between the highest and lowest resulting energy demands by the value of highest demand. It was found that the maximum difference in lighting demand is the highest, of which the highest value was related to the simulations for Harbin, i.e. 46% for layouts without shading and 35% for layouts with shading. The maximum difference in heating demand is smaller, and the highest value occurred in Amsterdam, being 11% for layouts without shading and 18% for layouts with shading. The maximum difference in cooling demand was the smallest, and the highest value occurred in Amsterdam, i.e. 8% for layouts without shading and 11% for layouts with shading.

The effect of space layout on the sum of the final energy for heating, cooling and lighting was also studied. For the calculation of final energy use, an air-source heat pump was assumed. The highest maximum difference in the final energy use occurred in Amsterdam, i.e. 8% for layouts with shading and 8% for layouts without shading.

The study has shown that finding the optimal space layout is not straightforward. As explained in the mechanism how space layout affects the BEP, different locations within a layout have different availability of solar radiation and daylight illuminance, while different functions have different needs in terms of set-points of illuminance, heating and cooling. These needs vary with the occupancy schedule. A good match between available energy and needs results in a lower energy demand. So, placing the right function in the right location helps to save the energy demand in total. However, the same location can be the best or worst location for all functions; for instance, rooms in the middle are best for the heating and cooling demand, and corners for lighting demand. There is no space layout where each function is on the location that suits this function best; the best space layout is the result of locating the function that benefits the most from a good location. Therefore, designing a space layout for minimising the energy demand is a 'battle' for the best location between functions that can benefit the most.

In this study, only the isolated effect of function allocation was identified. However, the methodology shown in Chapter 3 provides a basis for future research on the effect of the other design variables of space layouts on the BEP.

7.2.1.3 What are the current gaps and requirements for the automatic generation of space layout with energy performance optimisation? (Ch. 4 & Ch. 5)

In Chapter 4, studies relevant to the automatic generation of space layout with energy performance optimisation were collected, i.e. the references relevant to space layout, energy, and automation. Regarding the method used for the automatic generation of space layout with energy performance optimisation, most studies clearly separated the method into two phases: the automatic generation of space layout combined with optimisation (G-O), and the energy performance optimisation (EPO). Based on this, the analysis for the requirements were separated into two research domains, i.e. G-O and EPO, in terms of their respective requirements considering their integration.

The G-O phase aims to satisfy the design requirements for layout functionality. The design requirements for layout functionality were separated into topological requirements and geometric requirements. Based on 66 studies, seven methods for the automatic generation of space layout were categorised. The seven methods are: physically based method, mathematical programming method, graph-theory aided method, cell assignment method, space splitting method, occupant-trace

based generation method, and machine learning method. Additionally, criteria were proposed for the evaluation of the generation method, taking into account the requirements for functionality, automation performance, and the combination with optimisation. These criteria are generation speed, feasibility, variance, user-friendliness, capability of multi-floor, capability of irregularity, necessity of predefined boundary.

The EPO phase included energy performance assessment and optimisation. Regarding the energy performance assessment of space layouts, the requirements were identified in terms of energy indicators and zoning method. As for the energy indicators, future research should calculate the different energy indicators (for heating, cooling, lighting and ventilation) as much as possible, since there is a trade-off between different energy indicators. The assessment boundaries used should be clearly stated, differing between energy demand, final energy use, and primary energy use. The integration of daylight and natural ventilation into the energy simulation is also highly recommended for the calculation of the energy performance. As for the zoning method, the individual zoning method should be used in future research for greater accuracy and for modelling the different properties of different functions.

Regarding the requirements for energy performance optimisation, it is necessary to follow the classification of the design variables of space layouts as shown in Chapter 2. Furthermore, future research should develop an effective way to reduce computation time, since it is the dominant obstacle to energy performance optimisation. Five methods were identified to reduce the computation time, i.e. offline simulation, replacing simulation models with surrogate models, sequentially using different assessment methods, hierarchical structuring of design variables, and hierarchical structuring of optimisation objectives.

Chapter 4 proposed a comprehensive methodology regarding how to address the requirements of space layout, in terms of both functional and energy requirements. In Chapter 5, a method which only contributes to theoretical understanding of the effect of space layout on energy performance was developed. An optimisation design of space layout for the improvement of the energy performance was performed in Chapter 5. Based on the optimisation case, some reflections can be made on the requirements for the automatic generation of space layout with energy performance optimisation:

- Computation time is a big obstacle for the application of space layout generation with energy performance optimisation. Almost 25 days were needed for the multi-objective optimisation shown in Chapter 5, although four computers were used simultaneously for computation.

- Concerning the current technology, compromising the details of simulation is necessary to save computation time, although the accurate and detailed simulation is essential for this research. However, in practice, designers need to balance the computation time with simulation accuracy.
- Formulating the design variables for the generation of space layout considering the influence on the BEP. The relationship analysis in Chapter 5 shows that the design indicator of façade area to floor ratio (ff-ratio) is influential on the energy demand, while the design variables used to change layout variants were not directly relevant to the ff-ratio. Hence, in the phase of space layout generation, changing the values of design indicators, as the ff-ratio, would directly help to find the layout with optimal energy performance faster.
- Integrating functional requirements with the computational method developed in Chapter 5 if designers want to apply the method in practice. The computational method did not consider the functional requirements and generated layout variations featuring geometric properties that may only impact energy performance. In order to be applied in practice, the computational method needs to be modified, and designers can follow the design recommendations regarding how to integrate the method with functional requirements in Section 6.7.

7.2.1.4 How to computationally optimise space layout to improve the building energy performance? (Ch.5)

In Chapter 5, a computational method was developed to optimise space layout to improve the BEP for an office in Amsterdam. This method includes the following parts: a method to generate parametric space layout alternatives according to the relevant design variables, the assessment method integrating daylighting simulation and energy simulation for the relevant performance indicators, and automated by using an optimisation platform. The novelty of this method regards how the computational process is tuned to capture design variables and performance indicators relevant to understand the impact of space layout on energy performance.

As for the assessment of energy demands, daylight simulation was integrated into the energy simulation. The design variables included layout boundaries, interior partitions, and function allocation. Energy indicators included annual heating, cooling and lighting demands per layout area.

In order to test the design variables, the following generation procedure of space layout was developed: the layout boundary was changed by 8 control points; then the layout was split into 12 rooms with the same room area, and core and staircase locating in the middle of the layout; finally, other functions, i.e. office, meeting, canteen, and break room, were assigned to the 10 left-over rooms. In order to save computation time, four computers were used simultaneously to concurrently evaluate the energy demands of layout variations.

With the computational method developed, two rounds of optimisation were run in total. The first round included three single-objective optimisations for minimising heating, cooling and lighting demands separately. The second round had one optimisation with the multiple objectives to minimise heating, cooling and lighting demands together.

For the three single-objective optimisations for minimising heating, cooling and lighting demands, 297, 302, and 438 evaluations were run respectively. The results show that the three optimisations resulted in an improvement⁴ of 54% in lighting demand, 51% in heating demand, and 38% in cooling demand respectively. The longest computation time among the three optimisations was around 8 days. For the multi-objective optimisation for minimising the energy demands together, 1447 evaluations were run and took around 25 days. The resulting maximum differences in this study were much higher than the ones found in Chapter 2. This is because there were more design variables than the study of Chapter 2, in which only function allocation was changed.

7.2.1.5 What is the relationship between space layout and energy performance? (Ch. 5)

In Chapter 5, the computational method developed as described in the answer to research question 4 was also used to run a Design of Experiments (DOE). In total, 500 evaluations were run for the DOE, and its results were used to analyse the relationship between space layout and energy performance. For the relationship analysis, four types of design indicators of space layout were proposed, both for the overall layout and each function. The four types of design indicators include façade area ratio, floor area ratio, façade area to floor area ratio (ff-ratio), and height-to-

⁴ The improvement (%) is calculated as dividing the difference between maximum demand and minimum demand by the maximum demand

depth ratio, as explained in Section 5.3. These design indicators were calculated separately for different orientations. Both for the layout and per function, the annual heating, cooling and lighting demands were used to assess the BEP.

Correlation analysis was used to evaluate the relationships between design indicators of space layout and energy demands, and the following conclusions were drawn:

- Comparing the four types of design indicators, the ff-ratio showed stronger correlations with the energy demand than the façade area ratio, floor area ratio and height-to-depth ratio. For example, a clear correlation was found between the energy demand for the layout with ff-ratios in different orientations. However, no clear correlation was found with the floor area ratio, façade area to floor area ratio, and height-to-depth ratio, as shown in Section 5.4.4.
- Comparing different locations within the layout, corner rooms showed a stronger correlation with the energy demand than the other locations. For example, the ff-ratios in corners showed a greater correlation coefficient with the energy demand for the layout than other rooms, as shown in Section 5.4.4.
- Comparing the design indicator of one function with multiple rooms and the design indicator of the function per room, regarding its influence on the corresponding energy demand, the correlation coefficient of the function with multiple rooms is compromised by the room number. For example, a clear correlation was found between the ff-ratios for one office and the energy demand for this office, while no clear correlation was found between the ff-ratios for all offices (including 6 rooms) and the energy demand for all offices, as shown in Section 5.4.5.

7.2.1.6 How to apply the results of this research to practice? (Ch. 6)

The results and conclusions of this thesis were translated into design recommendations for energy-efficient space layout in Chapter 6. Following the classification of design variables of space layout as introduced in Chapter 2 and used throughout this thesis, design recommendations were given for function allocation, internal partitions between rooms, optimisation of space layout together with building geometry, and optimisation of space layout together with the building envelope.

In general, it can be concluded that very few straightforward design recommendations can be given. This is because the optimal space layout depends on many parameters, which means that the optimal space layout is too complex to predict. This is explained in detail in Chapter 6. Hence, for optimising the layout of a specific case, an optimisation method similar to the one applied in Chapter 5 is recommended. However, the method developed in Chapter 5 mainly addresses the optimisation for energy, on a theoretical understanding. Thus, as for the practical application of the optimisation results for designers, the functional requirements need to be added to this method, as shown in Section 6.7.

7.2.2 Main research question

How does space layout design affect the building energy performance and how can space layout design be optimised to improve the energy performance of office buildings?

- *Regarding the first part of the research question, answers are given in terms of the following aspects: the mechanism of how space layout affects the BEP, the design variables of space layout, the isolated effect of function allocation, and design indicators of space layouts that are highly relevant to energy demands.*

In terms of the mechanism, the factors that cause space layout to be influential on the BEP were identified, including different occupancy and comfort requirements, different availability of daylight and natural ventilation, different types of control for space heating, space cooling, ventilation and lighting systems. The details about the mechanism are shown in the answer to sub-question 1.

By changing design variables relevant to space layout, the factors that affect the BEP as described in the mechanism are changed, resulting in a different BEP as a consequence. A clear classification of building design variables based on their relationships with space layout design helps designers to influence and understand a change of the BEP. Details of the mechanism and the classification of design variables were shown in the answer to sub-question 1.

Secondly, the effect of function allocation, one of the design variables of space layouts, was tested. The heating, cooling and lighting demands were simulated for 11 layouts and compared for an office building in three climates. It was found that changing the function allocation can reduce the energy demand significantly, especially the demand for lighting. Details of the effect of function allocation can be found in the answer to sub-question 2.

In order to understand the relationship between space layout and the BEP, various design indicators of space layout were proposed and compared for their correlation with building energy demands. It was found that the façade area to floor area ratio is highly relevant to heating, cooling and lighting demands. Details of the relationship can be found in the answer to sub-question 5.

- *Regarding the second part of the research question, the answers are given in terms of the requirements for the generation of optimised space layout, the requirements for energy performance optimisation, as well as an optimisation method for demonstration.*

Regarding the generation of optimised space layout, firstly the thesis reviewed relevant references and identified seven methods for the automatic generation of space layout. Secondly, the criteria for the evaluation of the generation methods were proposed regarding the automation performance. Details of the methods for automatic generation and evaluation criteria can be found in the answer to sub-question 3.

Regarding energy performance optimisation, the requirements for energy performance assessment were given, as well as five methods to reduce computation time. These details can be found in the answer to sub-question 3.

Additionally, in order to demonstrate how to optimise space layout to improve the BEP, a computational method was developed for an office building in Amsterdam. A layout with 12 rooms was used, and design variables included layout boundaries, interior partitions, and function allocation. Energy indicators included the annual heating, cooling and lighting demands per layout area. Details of the computational method can be found in the answer to sub-question 4.

7.3 General conclusion

7.3.1 Most important findings

The most important finding is that the thesis proves that space layout can significantly affect the building energy performance (BEP), and can thus be used to improve it. Especially, the lighting demand is highly affected by the space layout chosen. This outcome was supported by two studies: (1) a study investigating the isolated effect of function allocation (i.e. the effect of different space layouts in which functions were allocated in different locations) on building energy demands (heating, cooling and lighting) in three climates, i.e. a temperate, cold and tropical climate; (2) a study optimising space layout design for the reduction of building energy demands (heating, cooling and lighting) in a temperate climate, in which design variables included layout boundaries, interior partitions and function allocation.

Based on this thesis, it can also be concluded that it is difficult to predict the best space layout in terms of energy performance, and very few concrete guidelines can be given. Therefore, manually designing the space layout for optimal energy performance is not feasible; in order to optimise space layout for energy performance, a computational approach is needed.

However, some general relationships were found between design variables related to space layout and energy performance. Façade area to floor area ratio was proven to be significantly influential on building heating, cooling and lighting demands, in terms of the entire layout and also for each function. Furthermore, corner rooms showed a stronger correlation with the energy demand than other locations within a layout.

Lastly, this thesis has provided the requirements for the automatic generation of space layout with energy performance optimisation, as well as a method for computational optimisation.

7.3.2 Scientific contribution

This thesis expands the understanding of how space layout affects energy performance. It systematically analysed space layout from the perspective of energy, in terms of its design variables, its relationship with and effects on building energy demands. It provided a novel classification of the building design variables regarding their relationship with space layout design. It also analysed the relationship between space layout and energy demands.

Existing literature on the combination of space layout and energy performance was very limited, and no clear studies were found on the isolated effect of space layout. This thesis provides a structured analysis to identify the isolated effect of space layout on the BEP. It helps to draw the attention of both designers and researchers on the influence of space layout on the BEP.

The requirements identified for the automatic generation of space layout and energy performance optimisation help to guide future research to explore more methods. The computational method developed for the automatic generation of space layout with energy performance optimisation provides designers with a method to improve the building energy performance by space layout design.

The proven effects of space layout on the BEP and the computational method developed for the automatic generation of space layout with energy performance optimisation would encourage the research of performant computational architecture to be more applied to space layout design. The classification of design variables, the integrated method for energy assessment, and the computational method provides a foundation for future research regarding space layout and energy performance.

7.3.3 Societal contribution

This research has proven that space layout design significantly affects the BEP, especially the demand for lighting. So, this will strengthen the role of architects as energy designers in the building design process, and may thus provoke new building typologies and design concepts for energy-efficient buildings.

Space layout design is one of the most important tasks of architectural design. So, building design following design recommendations of this research can benefit the target of zero-energy building.

The computational method developed for the automatic generation of space layout with energy performance optimisation provides designers and researchers with a demonstration of how to generate space layout to optimise the BEP.

7.4 Discussion

7.4.1 Limitations and challenges

Several studies were conducted in this PhD research, and the results could answer the research questions and meet the aims of the research to a substantial extent. Nevertheless, there are still some limitations of this research, as addressed below.

The models used in this research, both for testing the effect of space layout on the BEP and for the computational method, did not consider the **surroundings of the building**. In an urban context, the surrounding buildings highly influence the amount of solar radiation, daylight illuminance, and natural ventilation received by different rooms within a layout. The best and worst locations for each energy demand could differ from the ones that were found in this research.

The study for investigating the effect of space layout on the BEP and the study for the computational method were conducted for a planar layout. However, a **vertical change** in space layout according to different vertical conditions, resulting both from internal partitions and from the influence of surrounding buildings, would cause a big difference in energy demands between layouts.

In the study investigating the effect of space layout on the BEP, only the effect on heating, cooling and lighting demand was considered. In the study, the influence of daylight performance on the thermal demand of the building was considered. However, **natural ventilation** can also influence thermal performance considerably. Moreover, different building shapes and different orientations of a layout can affect the amount of natural ventilation, resulting from air pressure differences, air velocity and direction. If natural ventilation is included, the difference in thermal demands between layouts is expected to be higher than what was shown in this research.

As for the method used to identify the isolated effect of space layout on the BEP, simulation was used to determine the energy demand of each space layout. However, the simulated energy demand was not validated by measured data of the energy demand of a real building. For a complete **validation**, it would be recommended to compare the measured energy demands of different space layouts in a real building with the simulated values, in order to identify the isolated effect of space layout. However, within the timeframe of this research it was impossible to find a building with different layouts, which have different function allocations, while having the same other design parameters, i.e. functions, occupancy schedules, envelopes, and internal partitions, etc.

Chapter 5 aims to identify the relationship between space layout and energy performance and gain theoretic understanding about it. So, the computational method developed in Chapter 5 generated schematic space layouts with the goal of testing large set of variations featuring geometric properties that may impact the energy performance. As a result, the layouts were generated to make rather extreme variations; they were not generated with the focus on **functionality** and direct applicability in practice. Thus, as shown in Chapter 5 the generated layouts include also configurations that can be quite impractical. In order to apply the generated schematic layouts in practice, designers would need to select the generated layouts based on functionality (and other) criteria, and elaborate them from schematic configurations to proper architectural layouts. Alternatively, in order to apply the computational method in practice, designers need to modify this computational method and integrate it with the functional requirements of space layout as shown in Section 4.3.1.

The resulting differences in energy demands between layouts shown in Chapter 3 and 5, and the identified relationship between space layout and energy demands in Chapter 5, were based on the values the variables relevant to energy performance, and the values assigned to these variables were mainly based on local regulations. The variables relevant to energy performance can be categorised into two types of variables. The first type is the ones which are dependent on space layout design, like occupancy, schedule, control of lighting and shading system, and internal loads of equipment. For instance, the occupancy is changed as a consequence of the change of space layout, and the occupancy differs if an office is changed from a cellular office to an open office. The other type of the variables is independent variables, like U values, WWR, infiltration, set-points, and glazing properties. They can be changed independently, not as a consequence of the change in space layout design. However, all these **variables relevant to energy performance** can influence the resulting energy demand of a given space layout and thereby the difference in energy demands between layouts shown in Chapter 3 and 5. Related to the characteristics

of the functions, a higher difference in these variables between functions results in a higher difference in energy demands between functions and between layouts. And vice versa. For example, if people keep the lighting turned on in all rooms, there will be no difference in lighting demand between different rooms and the location of the room will not influence this demand. Therefore, for future application of the results shown in this thesis, the influence of these variables should be taken into account.

7.4.2 Recommendations for future development

In Chapter 6, recommendations are provided for designers who want to optimise space layout to improve the energy performance. The following recommendations are formulated specially for future research.

Regarding the assessment of building energy demands, integration of daylight and natural ventilation was recommended into thermal energy simulation. However, in this thesis, only daylight simulation was integrated into the energy simulation of heating and cooling. So, for future research, integrating natural ventilation with energy simulation is recommended, to better understand how space layout affects natural ventilation within the building and building energy demands as a consequence. In addition, in an urban context, surrounding buildings should be considered for their influence on the building performance.

Regarding the design variables of space layout as shown in Table 7.1, function allocation was tested for its isolated effect on building energy demands. Furthermore, the combined effect of function allocation, layout boundary, and interior partition on building energy demands were also tested.

TABLE 7.1 Classification of building design parameters affecting BEP, regarding their relationships with space layouts

Design variables of space layout (with a non-fixed boundary)		Space properties		Envelope design
Space layout design (within a fixed boundary)		Functional requirements	Use of spaces	
<ul style="list-style-type: none"> – Space location – Space dimension – Space form – Interior partitions – Space orientation 	<ul style="list-style-type: none"> – Boundary dimension – Boundary form – Orientation 	<ul style="list-style-type: none"> – Heating set-point – Cooling set-point – Required lighting level – Required ventilation 	<ul style="list-style-type: none"> – Occupancy density and schedules – Equipment gains and schedules – Control strategies 	<ul style="list-style-type: none"> – Insulation – Window area – Window location – Glazing type – Shading type – Air tightness

In addition to the design variables directly associated with space layout (i.e. two columns on the left of Table 7.1), there are also other variables that affect BEP. The other design variables (such as the WWR) can impact the effect of space layout on the energy performance. For example, for a building with larger windows, the effect of space layout on the BEP may be more significant than the effect of the same layout for a building with much smaller windows. In addition, when allowing to optimise space layout design in combination with the WWR, this may lead to an even greater effect on the BEP. Hence, when having many levels of freedom of the design variables shown in Table 7.1, many more optimisation studies can be performed.

In this study, however, only the influence of of the WWR and U value were tested on the effect of space layout on the BEP. It is recommended to test more design variables in combination with space layout design, such as thermal mass, set-points, schedules, lighting efficiency and control types, shading control types, and facade properties (thermal and optical property of glazing and shading devices).

Regarding the automatic generation of space layout with energy performance optimisation, only a floor plan of one single floor was investigated in this research. It is recommended to have more flexibility for the layout variants. Furthermore, a more generic generation method would expand its applicability for both research and practice.

The long computation time is a big obstacle of the computational method for space layout, for both research and its application to practice. So, future research should formulate a more practical method to reduce computation time, based on the recommendations listed in Section 4.4.2.2, or try to improve the developed method used to reduce computational time as shown in Chapter 5.

7.5 Outlook

This research showed the great effect of space layout on the BEP, and also developed a computational method for the automatic generation of space layout with energy performance optimisation. The outlook is given regarding the applicability of the research results and also the vision for the future development.

The effect of space layout on the BEP found in this study is not only applicable to office buildings. As long as the functions in a building have different properties and requirements, such as the temperature set-point and occupancy schedules, space layout design plays an important role in saving energy demands of the whole building. It is therefore applicable to buildings with multiple functions, such as residences, offices, restaurants, or hospitals. So, when designing these types of building, designers could consider space layout design as a method to improve the BEP.

Integrating the automatic generation of space layout with energy performance optimisation requires integration of disciplines and also different software programmes. The relevant disciplines include daylight and energy simulations, optimisation theory, and computational design. The absence of any of these disciplines would result in the failure of the research. The software programmes used in this research include EnergyPlus and Radiance via Ladybug and Honeybee, Grasshopper, Python, and modeFRONTIER. This implies high requirements for researchers and designers, regarding research, practice and also architectural education.

Nowadays, ever more tools have been developed for the automatic generation of floor plans, which help architects to leverage their designs in the early design phases of a project, such as Finch [1] and ArchiGAN [2]. These tools provide easily operable interfaces and attract the interest of both designers and researchers in space layout design. Nevertheless, they can replace some parts of work for architects. This raises requirements for architects.

References

- [1] J. Wallgren, FINCH, (n.d.). <https://finch3d.com/#> (accessed February 18, 2021).
- [2] S. Chaillou, ArchiGAN, English. (n.d.). http://stanislaschaillou.com/thesis/GAN/unit_program/ (accessed February 18, 2021).

Curriculum Vitae

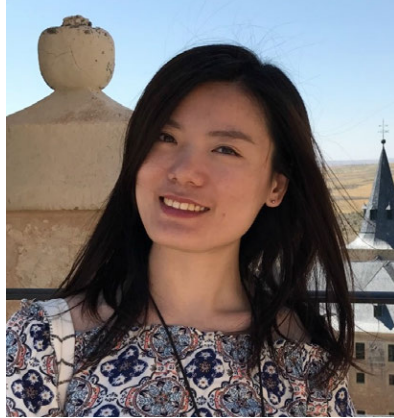

- 2017.01-2021.07 PhD candidate, Architectural Engineering and Technology,
Delft University of Technology, the Netherlands
- 2015.10-2016.12 Guest researcher, Architectural Engineering and
Technology,
Delft University of Technology, the Netherlands
- 2011.09-2015.09 Architect, Architectural Design and Research Institute
Harbin Institute of Technology, China
- 2011.09-2014.01 Master of Architectural Design and Theory,
Harbin Institute of Technology, China
- 2006.09-2011.07 Bachelor of Architecture, China University of Petroleum,
China

List of Publications

Journal papers

T Du, M Turrin, S Jansen, A van den Dobbelsteen, F De Luca, Relationship analysis and optimisation of space layout to improve the energy performance of office buildings, *Journal of Building and Engineering* (under review)

T Du, S Jansen, M Turrin, A van den Dobbelsteen, Effect of space layouts on the energy performance of office buildings in three climates, *Journal of Building and Engineering*, 39, 102198, 2021

T Du, M Turrin, S Jansen, A van den Dobbelsteen, J Fang, Gaps and requirements for automatic generation of space layouts with optimised energy performance, *Automation in Construction* 116, 103132, 2020.

T Du, S Jansen, M Turrin, A van den Dobbelsteen, Effects of architectural space layouts on energy performance: A review, *Sustainability* 12 (5), 1829, 2020.

Conference papers

T Du, S Jansen, M Turrin, A van den Dobbelsteen, Impact of space layout on energy performance of office buildings coupling daylight with thermal simulation, REHVA 13th HVAC World Congress, CLIMA, Bucharest, Romania, 2019, 05

T Du, M Turrin, S Jansen, A van den Dobbelsteen, A Review on Automatic Generation of Architectural Space Layouts with Energy Performance Optimization, 4th International Conference on Building Energy & Environment, Melbourne, Australia, 2018, 02

Space layout and energy performance

Parametric optimisation of space layout for the energy performance of office buildings

Tiantian Du

Studies have shown that space layout design can impact the building energy performance (BEP). However, its isolated effect on the BEP has not been identified yet. Performative computational architecture has proven to be effective to improve the BEP. However, only a few studies have tried to apply the performative computational architecture to space layout design. This research aims to investigate how space layout affects BEP, and to develop a computational optimisation method for space layout to improve the BEP of office buildings.

Firstly, the mechanism on how space layout affects the BEP and how much energy is affected by space layout were identified through literature review and simulation. 11 layouts with different function allocations were simulated and compared. The outcome showed that layout variance affected lighting the most, and the maximum difference happened in Harbin, being 46% without shading and 35% with shading.

As a follow-up, another literature review was conducted, which identified the functional requirements of space layout design, methods for automatic generation of space layout, and requirements for energy performance optimisation. In addition, a computational method was developed to optimise space layout design for energy performance improvement, regardless of functional requirements. As a result, the relationship between space layout and energy demands were recognised.

In conclusion, space layout has proven to be a significant influence on the BEP, and conscientious design can improve it. For optimal energy performance, manual design of space layout is not feasible; in order to do that, a computational approach is needed.