

# 9 Reflecting upon PAS

---

chapter 2	CRE alignment state of the art and scientific gap
-----------	---

**Preference-based Accommodation Strategy (PAS)  
design and decision approach**

Developing PAS		Testing PAS			Evaluating PAS
chapter 3	chapter 4	chapter 5	chapter 6	chapter 7	chapter 8
fifteen basic concepts and definitions from decision, design and management theory	2nd procedural rationality	steps			steps
	3rd structural rationality		stakeholders & activities		stakeholders & activities
	1st substantive rationality			model	model

chapter 9	Reflecting upon PAS
-----------	---------------------

chapter 10	Conclusions and recommendations
------------	---------------------------------

# 9 Reflecting upon PAS

---

By now, the PAS design decision method is familiar and it is known that:

- 1 The Preference-Based Design procedure could be adapted and implemented into an accommodation strategy formation project so that it can be used at real estate portfolio level in CRE alignment process (see chapter 4);
- 2 The stakeholders were able to perform all PAS design decision steps and accepted the outcome (see chapter 5 and 6);
- 3 The facilitator and the systems engineers were able to represent the pilots in mathematical decision models (see chapter 7), and;
- 4 The stakeholders evaluated PAS design decision method positively (see chapter 8).

In paragraph 9.1 it is shown that the PAS design decision method can be used as add-on to current CRE alignment management models. However, using the PAS method as add-on in these models creates managerial and methodical difficulties. The structure of these models is often not congruent with the structure of the PAS method (see chapter 2). An add-on of the PAS method in an alignment model does not fit well. To avoid these difficulties in the pilot studies a specific CRE alignment management system is set up which is congruent with the PAS design decision system: the PAS design decision management system.

The PAS design decision method has been structured from a decision making perspective around Kickert's three rationalities (components) (in De Leeuw, 2002). To complete PAS, PAS is described solely as design method in paragraph 9.2. In paragraph 9.3 the PAS management system is structured from a systems' management perspective. From this perspective the three components can be described from the organizations' point of view as well as the CRE manager and facilitator that executes PAS. Management as such is seen as steering in this thesis as is explained in chapter 3. PAS management system is defined based on a systems perspective as following the chosen basic concepts and definitions as explained in paragraph 3.1.14 and 3.1.15.

## 9.1 PAS as add-on to existing CRE alignment models

PAS opens the ‘black box’ of decision making in existing CRE alignment models by using a design and decision approach to CRE alignment. Initially, PAS was not intended to replace current alignment models. “It offers an approach to design alternatives and select the best design alternative and can be incorporated as an add-on in existing CRE alignment models. The existing alignment model would function as reference model to support stakeholders to determine relevant variables in line with their objectives. To support the claim that PAS can be used as add-on two examples will be given” (Arkesteijn et al, 2017, p. 260). In the first example, PAS is added to DAS frame (Den Heijer, 2011, based on de Jonge et al., 2009). PAS steps can be implemented by changing four parts of the framework (see [Figure 9.1](#)).

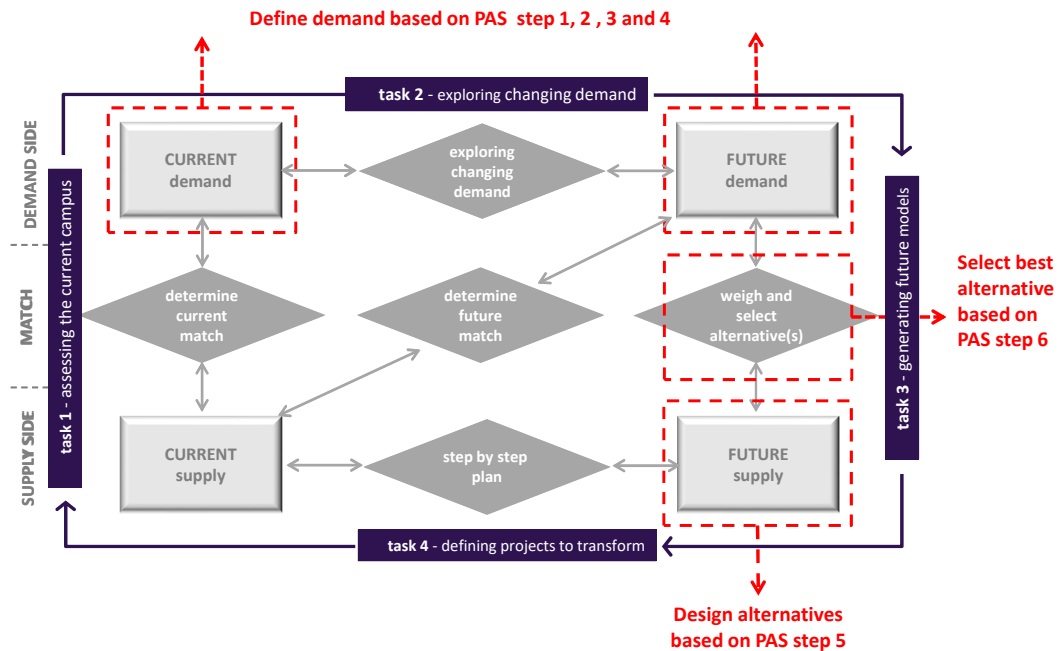
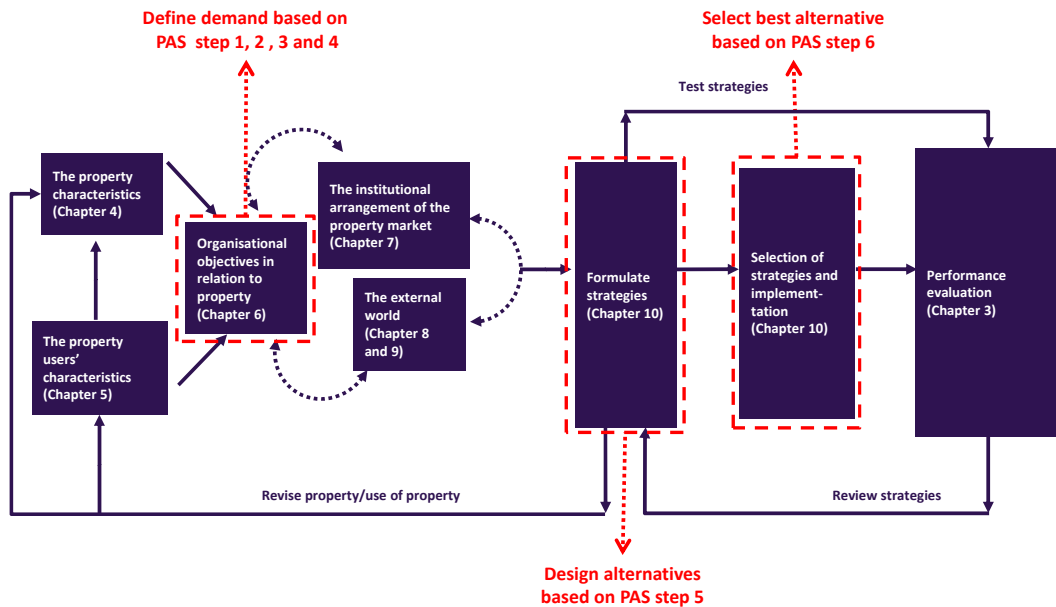

FIG. 9.1 PAS (indicated with dotted lines) implemented in DAS Note from Arkesteijn et al., 2017, p. 261 and DAS from Den Heijer, 2011, based on De Jonge et al. 2009

As a second example, ... PAS ... is added to Edwards and Ellison's alignment model [see **Figure 9.2**]. The 'organizational objectives in relation to property' can be expressed based on PAS steps 1 to 4, while the 'strategies can be formulated' based on PAS step 5 and the selection based on PAS step 6. The variables that are defined by the stakeholders to select the best option could also, in a later stage, be used to carry out the performance evaluation. Of course, during the use of a CRE portfolio, the requirements can -and probably will- change over time. PAS allows alterations in variables, preference ratings, weights as well as in constraints over time (Arkesteijn et al, 2017, p. 260).



**FIG. 9.2** PAS steps (indicated with black dotted lines) implemented in Alignment model (Edwards & Ellison, 2003, p. 18) © Used with permission. All rights reserved. No part of this publication may be reproduced, stored in a retrieval system, or transmitted, in any form or any means, electronic, mechanical, photocopying, recording or otherwise, except as permitted by the UK Copyright, Designs and Patents Act 1988, without prior permission of the original publisher. Note Figure from Arkesteijn et al., 2017, p. 261

What becomes apparent in these examples, is that PAS steps are used to enhance the current alignment models. In PAS as add-on, the PAS components *stakeholders & activities* and *model* are not taken into account. Furthermore, there might be too much overlap between PAS and existing models. Because existing alignment models have elements of a both substantive rationality in the so-called reference models and of the procedural rationality. It is recommended, to test the use of PAS as add-on to other models and/or to use PAS in combination with a reference model pur sang to select relevant decision variables.

## 9.2 PAS as design methodology

In this paragraph, PAS is presented solely as design methodology. PAS is summarized in four figures, this can be seen as a map that shows how the different parts are connected from a design point of view. In **Figure 9.3** it is explained how the variables and related aspects are set.

inter-stakeholder weight set by subject owner	stakeholders	problem analysis		step 1				step 2			step 3		resulting in	
				decision variables	bottom reference alternative	top reference alternative	intermediate reference alternative	decision variable stakeholder weight	decision variable inter-stakeholder weight					
ws1	s1	objective 1	problem	with or without the use of a reference model define relevant decision variables	dv1	s1-dv1(x0, y0)	s1-dv1(x1, y1)	s1-dv1(x2,y2)	dv-sw1,1	dv-w1,1				
					dv2	s1-dv2(x0, y0)	s1-dv2(x1, y1)	s1-dv2(x2,y2)	dv-sw1,2	dv-w1,2				
					dv3	s1-dvn(x0, y0)	s1-dvn(x1, y1)	s1-dvn(x2,y2)	dv-sw1,n	dv-w1,n				
ws2	s2	objective 1	problem 1	model define relevant decision variables	dv1	s2-dv1(x0, y0)	s2-dv1(x1, y1)	s2-dv1(x2,y2)	dv-sw2,1	dv-w2,1				
					dv3	s2-dv3(x0, y0)	s2-dv3(x1, y1)	s2-dv3(x2,y2)	dv-sw2,3	dv-w2,3				
					dv4	s2-dvn(x0, y0)	s2-dvn(x1, y1)	s2-dvn(x2,y2)	dv-sw2,n	dv-w2,n				
wsn	sn	objective 1	problem 2	model define relevant decision variables	dv2	sn-dv2(x0, y0)	sn-dv2(x1, y1)	sn-dv2(x2,y2)	dv-sw3,2	dv-w3,2				
					dv4	sn-dv4(x0, y0)	sn-dv4(x1, y1)	sn-dv4(x2,y2)	dv-sw3,4	dv-w3,4				
					dv4	sn-dv2(x0, y0)	sn-dvn(x1, y1)	sn-dvn(x2,y2)	dv-sw3,n	dv-w3,n				
								n*100%	100%					

**Legend**

s	stakeholder	n	last number of the serie	dvs	decision variable stakeholder weight
w	weight	dv	decision variable	dvw	decision variable inter-stakeholder weight
ws	weight of stakeholder				

FIG. 9.3 Design methodology for PAS steps 1 to 3 ordered by stakeholder

In the second column all stakeholders that are involved are shown. Once it is known, who and how many stakeholders are involved, the subject owner can determine the weights between the stakeholders resulting in a total of 100%. In this table, the objectives, problems, variables, preference curves and weights are displayed. After the stakeholders have determined the weights of their decision variables, also adding up to a 100 per stakeholder, the decision variable inter-stakeholder weight can be calculated. The stakeholders can use a reference model to determine relevant decision variables for the objectives they have. By using such a reference model, they benefit from existing knowledge. However, they are free to choose which reference model to use and which decision variables they find useful for their particular situation and problem. It should be noted here as well, that the stakeholders as well as the subject owner can change any of their input during the iterative process.

That is a key element in PAS that enables them to become reflective practitioners (Schön, 1987).

As explained in chapter 3, the objective and problem are the two sides of the same ‘medal’. The relationship of a stakeholder, objectives, problems and variables can be 1:1, 1:n or n:1. As, has been shown in paragraph 5.1 stakeholders can define a problem without an objective, or an objective without a problem or a decision variable without a problem and an objective. This table combines the information of a pilot study as displayed in [Figures 5.6, 5.7, 5.8, 5.9, 5.10, 5.11, 5.18 and 5.20](#).

Once all information is known, the table can be ordered by the decision variable instead of the stakeholder (see [Figure 9.4](#)). This will allow the facilitator and the system engineer to build the mathematical model and propose relevant interventions. Each decision variable has an intervention, following the law of Asby as described in De Leeuw (2002, p. 160) “The law of the requisite variety of Ashby states that there must be at least as many different steering measures as the number of disruptions”.

step 1		step 3	step 2			resulting in
decision variables	stakeholders	decision variable stakeholder weight	bottom reference alternative	top reference alternative	intermediate reference alternative	inter-stakeholder weight
dv1	s1	dv-sw1,1	s1-dv1(x0, y0)	s1-dv1(x1, y1)	s1-dv1(x2,y2)	dv-w1
	s2	dv-sw1,2	s2-dv1(x0, y0)	s2-dv1(x1, y1)	s2-dv1(x2,y2)	
dv2	s1	dv-sw2,1	s1-dv2(x0, y0)	s1-dv2(x1, y1)	s1-dv2(x2,y2)	dv-w2
	sn	dv-sw2,n	sn-dv2(x0, y0)	sn-dv2(x1, y1)	sn-dv2(x2,y2)	
dv3	s2	dv-sw3,2	s2-dv3(x0, y0)	s2-dv3(x1, y1)	s2-dv3(x2,y2)	dv-w3
dv4	sn	dv-sw4,n	sn-dv4(x0, y0)	sn-dv4(x1, y1)	sn-dv4(x2,y2)	dv-w4
dvn	s1	dv-swn,1	s1-dvn(x0, y0)	s1-dvn(x1, y1)	s1-dvn(x2,y2)	dv-wn
	s2	dv-swn,2	s2-dvn(x0, y0)	s2-dvn(x1, y1)	s2-dvn(x2,y2)	
	sn	dv-swn,n	sn-dv2(x0, y0)	sn-dvn(x1, y1)	sn-dvn(x2,y2)	
n*100%						100%

**Legend (new abbreviations)**

dv-sw    decision variable stakeholder weight                                  dv-w    decision variable inter-stakeholder weight

FIG. 9.4 PAS steps 1 to 3 ordered by decision variables

Figure 9.4 combines the information as shown in [Figure 9.3](#) combined with [Figure 5.12](#) in a pilot study.

In [Figure 9.5](#), it is shown how the decision variables, objects, interventions and states are related.





step 1		step 2				resulting	step 3													
decision variables	stakeholder	decision variable stakeholder weight	bottom reference alternative	top reference alternative	intermediate reference alternative	inter-stakeholder weight	object													
							i1,1	i1,2	i1,3	i1,4	i1,n	i2,1	i2,2	i2,3	i2,4	i2,n				
d1	s1	dr=sw1,1	i1-dv1(i0,y)	i1-dv1(i1,y)	i1-dv1(i2,y)	dr-w1	dr-v1,1,1	ps-dr-v1,1,1,1	dr-v1,1,2	ps-dr-v1,1,2,1	ps-dr-v1,1,2,2	dr-v1,1,2	ps-dr-v1,1,3,1	ps-dr-v1,1,3,2	dr-v1,1,2	ps-dr-v1,1,4,1	ps-dr-v1,1,4,2	dr-v1,1,2	ps-dr-v1,1,n,1	ps-dr-v1,1,n,2
	s2	dr=sw1,2	i2-dv1(i0,y)	i2-dv1(i1,y)	i2-dv1(i2,y)		dr-v1,1,1	ps-dr-v1,1,1,1	dr-v1,1,2	ps-dr-v1,1,2,1	ps-dr-v1,1,2,2	dr-v1,1,2	ps-dr-v1,1,3,1	ps-dr-v1,1,3,2	dr-v1,1,2	ps-dr-v1,1,4,1	ps-dr-v1,1,4,2	dr-v1,1,2	ps-dr-v1,1,n,1	ps-dr-v1,1,n,2
d2	s1	dr=sw2,1	i1-dv2(i0,y)	i1-dv2(i1,y)	i1-dv2(i2,y)	dr-w2	dr-v2,1,1	ps-dr-v2,1,1,1	dr-v2,1,2	ps-dr-v2,1,2,1	ps-dr-v2,1,2,2	dr-v2,1,2	ps-dr-v2,1,3,1	ps-dr-v2,1,3,2	dr-v2,1,2	ps-dr-v2,1,4,1	ps-dr-v2,1,4,2	dr-v2,1,2	ps-dr-v2,1,n,1	ps-dr-v2,1,n,2
	sn	dr=sw2,n	sn-dv2(i0,y)	sn-dv2(i1,y)	sn-dv2(i2,y)		dr-v2,1,1	ps-dr-v2,1,1,1	dr-v2,1,2	ps-dr-v2,1,2,1	ps-dr-v2,1,2,2	dr-v2,1,2	ps-dr-v2,1,3,1	ps-dr-v2,1,3,2	dr-v2,1,2	ps-dr-v2,1,4,1	ps-dr-v2,1,4,2	dr-v2,1,2	ps-dr-v2,1,n,1	ps-dr-v2,1,n,2
d3	s1	dr=sw3,1	i1-dv3(i0,y)	i1-dv3(i1,y)	i1-dv3(i2,y)	dr-w3	dr-v3,1,1	ps-dr-v3,1,1,1	dr-v3,1,2	ps-dr-v3,1,2,1	ps-dr-v3,1,2,2	dr-v3,1,2	ps-dr-v3,1,3,1	ps-dr-v3,1,3,2	dr-v3,1,2	ps-dr-v3,1,4,1	ps-dr-v3,1,4,2	dr-v3,1,2	ps-dr-v3,1,n,1	ps-dr-v3,1,n,2
	sn	dr=sw3,n	sn-dv3(i0,y)	sn-dv3(i1,y)	sn-dv3(i2,y)		dr-v3,1,1	ps-dr-v3,1,1,1	dr-v3,1,2	ps-dr-v3,1,2,1	ps-dr-v3,1,2,2	dr-v3,1,2	ps-dr-v3,1,3,1	ps-dr-v3,1,3,2	dr-v3,1,2	ps-dr-v3,1,4,1	ps-dr-v3,1,4,2	dr-v3,1,2	ps-dr-v3,1,n,1	ps-dr-v3,1,n,2
dn	s1	dr=swn,1	i1-dvn(i0,y)	i1-dvn(i1,y)	i1-dvn(i2,y)	dr-wn	dr-vn,1,1	ps-dr-vn,1,1,1	dr-vn,1,2	ps-dr-vn,1,2,1	ps-dr-vn,1,2,2	dr-vn,1,2	ps-dr-vn,1,3,1	ps-dr-vn,1,3,2	dr-vn,1,2	ps-dr-vn,1,4,1	ps-dr-vn,1,4,2	dr-vn,1,2	ps-dr-vn,1,n,1	ps-dr-vn,1,n,2
	s2	dr=swn,2	i2-dvn(i0,y)	i2-dvn(i1,y)	i2-dvn(i2,y)		dr-vn,1,1	ps-dr-vn,1,1,1	dr-vn,1,2	ps-dr-vn,1,2,1	ps-dr-vn,1,2,2	dr-vn,1,2	ps-dr-vn,1,3,1	ps-dr-vn,1,3,2	dr-vn,1,2	ps-dr-vn,1,4,1	ps-dr-vn,1,4,2	dr-vn,1,2	ps-dr-vn,1,n,1	ps-dr-vn,1,n,2
sn	dr=swn,n	sn-dvn(i0,y)	sn-dvn(i1,y)	sn-dvn(i2,y)			ps-dr-vn,1,1,n		ps-dr-vn,1,1,2,n	ps-dr-vn,1,2,n		ps-dr-vn,1,1,3,n	ps-dr-vn,1,3,n		ps-dr-vn,1,4,n	ps-dr-vn,1,4,n		ps-dr-vn,1,1,n	ps-dr-vn,1,2,n	
		n=100%					100%													

In **Figure 9.5**, it is shown that for an object an intervention (i) leads to a new state(sv). The state vector is an alternative in the form  $(x_1, \dots, x_{16})$  where  $x_j$  is the state of an object j as explained in paragraph 4.5.1. For this new state, the decision variable value for each of the decision variables is known and can be calculated. Subsequently based on each of the preference curves per stakeholder and decision variable, the preference rating per decision variable for each stakeholder can be calculated. If this preference rating is known, the difference (delta) between the current state (always st1) and the new state can be determined. In the figure all options (for each intervention and state) are given. However, when designing new CRE portfolios, i.e. a new alternative, each object can only have one state, i.e. only one intervention can be chosen. Next to that, in this example, it is assumed that the stakeholders for each decision variable sets a demand linked to an object, therefore each of the decision variables has a preference score per object, per intervention. The following two interventions 'doing nothing' and 'closing the object' are always available. The intervention 'doing nothing' is identical to the current state (situation or supply). If a stakeholder sets a demand for a decision variable which is linked to the total CRE portfolio, these preference scores cannot be calculated (see **Figure 9.6**).

In **Figure 9.6**, a new state is displayed. In this example it is assumed that the stakeholders set a demand for an object only for decision variable 1, while the others decision variables are assumed to be set for the total portfolio. This means that only decision variable 1 has preference scores and delta preference scores for each object. As can be seen in the example for object 1 the chosen intervention is 3 and for object n, it is n. For object 2, the chosen intervention is 1. This means 'doing nothing', therefore the delta preference score is automatically 0. The chosen interventions lead to a state vector of  $(3, 1, n)$ .

The calculation of the decision variable values and the preference scores depend on the type of variable and follows the formulas as explained in paragraph 4.5. Sometimes, the calculation is the average of all decision variables values. And

sometimes it is the minimum objects' decision variables values (remember the walking distance).

Figure 9.6 combines the information as shown in Figure 9.3, Figure 9.4 combined the interventions as explained in for instance paragraph 5.1.6 and 6.1.1 leading to the output as displayed in Figure 5.23 and Figure 6.6.

step 1		step 5							step 6		
decision variables	stakeholders	object X1		object X2		object Xn			portfolio of objects (X1, X2, Xn)		
		i 1,3		i 2,1		i n,n			intervention vector iv (3,1,n)		
		st1,3		s2,1		sn,n			new portfolio alternative, i.e. sv (3,1,n)		
dv1	s1	ps-dv-v 1,1,3,1	dps-dv-v 1,1,3,1	ps-dv-v 1,2,1,1	ps-dv-v 1,n,n,1	dps-dv-v 1,n,n,1	average ps-dv1-v-sv (3,1,n)	s1	dps-dv1-v-sv (3,1,n)		
	s2	ps-dv-v 1,1,3,2	dps-dv-v 1,1,3,2	ps-dv-v 1,2,1,2	ps-dv-v 1,n,n,2	dps-dv-v 1,n,n,2	minimum ps-dv1-v-sv (3,1,n)	s2	dps-dv1-v-sv (3,1,n)		
dv2	s1	n.a.	n.a.	0	n.a.	n.a.	ps-dv2-v-sv (3,1,n)	s1	dps-dv2-v-sv (3,1,n)		
	sn	n.a.	n.a.	0	n.a.	n.a.		sn	dps-dv2-v-sv (3,1,n)		
dv3	s2	n.a.	n.a.	0	n.a.	n.a.	ps-dv3-v-sv (3,1,n)	s2	dps-dv3-v-sv (3,1,n)		
dv4	sn	n.a.	n.a.	0	n.a.	n.a.	ps-dv4-v-sv (3,1,n)	sn	dps-dv4-v-sv (3,1,n)		
dvn	s1	n.a.	n.a.	0	n.a.	n.a.	ps-dvn-v-sv (3,1,n)	s1	dps-dvn-v-sv (3,1,n)		
	s2	n.a.	n.a.	0	n.a.	n.a.		s2	dps-dvn-v-sv (3,1,n)		
	sn	n.a.	n.a.	0	n.a.	n.a.		sn	dps-dvn-v-sv (3,1,n)		

**Legend (new abbreviations)**

ops	overall preference score or preference rating	ill	preference score per stakeholder	ops-s1-sv (3,1,n)	dops-s1-sv (3,1,n)
dops	delta overall preference score or preference rating			ops-s2-sv (3,1,n)	dops-s2-sv (3,1,n)
				ops-sn-sv (3,1,n)	dops-sn-sv (3,1,n)
			overall preference score new portfolio	ops-sv(3,1,n)	dops-sv(3,1,n)
			added value new portfolio	(ops-sv(3,1,n))-(ops-sv(1,1,1))	

FIG. 9.6 PAS step 4 a designed alternative with overall preference score ordered by decision variables

## 9.3 PAS design decision management system

---

The PAS design decision system has been extended into a design decision management system, following De Leeuw's system modeling approach (2002). With the PAS design decision management system the PAS design and decision method can be represented from the organizations' point of view.

In this paragraph first the basic model features and the overall structure of the PAS design decision and management system are elaborated. Then the four subsystems are described: the PAS set up and steer subsystem; the PAS programming subsystem; the PAS decision modeling subsystem; and the PAS design subsystem. The subsystems are each described as a management system with a steering unit, a steered unit, an environment, steering measures and information flows. In the PAS steering system the organization that will execute and steer the PAS design and decision method is established; the other three systems are all a part of the management system.

The PAS steering subsystem consists of acknowledging a CRE alignment problem and formally starting a process to solve the problem together with the involved stakeholders under guidance of a facilitator and systems engineer. The input is the real-life system of the current stakeholders, including their current knowledge of the organization and its environment. The output of the system is a preliminary problem description.

- In the PAS modeling subsystem the system engineer and facilitator build a mathematical model based on this program of requirements.
- The PAS programming subsystem is defined as the transformation of a vague problem situation into a well-defined problem. The transformation to a well described problem is done by the selected stakeholders in interviews with the facilitator. The output of the system is a program of requirements.
- In the PAS decision modeling subsystem the system engineer and facilitator build a mathematical model based on this program of requirements.
- In the PAS design subsystem the stakeholders design alternative real estate portfolios in the mathematical model to solve the problem, i.e. reach the objectives that are defined in the program of requirements.

The steering, programming, modeling, and design subsystems, and the steering measures, and information flows between them constitute the core of the PAS management system. For each subsystem the steering unit, steered system, the

steering measures and information between them are described as well as its input, output and environment .

The basic features and the structure of PAS design decision management system as a whole are presented in paragraph 9.2.1, where after each of the four subsystems of the PAS management system are discussed separately in subsequent paragraphs:

- Steering subsystem in paragraph 9.2.2;
- Programming subsystem in 9.2.3;
- Modeling subsystem in 9.2.4;
- Design subsystem in 9.2.5.

### 9.3.1 **Basic features and structure of PAS design decision management model**

---

The basic features of the representation of PAS in a management model are:

#### **The operational goal (function)**

The goal (function) of the PAS design management system is to enable stakeholders to design together a corporate real estate portfolio that adds optimal value to the organization. This management system can be seen as human activity system, in general consisting of the following human activities:

A PAS facilitator together with the CRE manager, the responsible manager and relevant internal and external stakeholders of an organization solve a strategic real estate portfolio problem. All stakeholders, as designers and decision makers, define their program of requirements based on which a systems engineer builds a mathematical decision model of the portfolio (as a set of real estate objects). All stakeholders then together design alternative corporate real estate portfolios in this model and select the alternative that adds most value to the organization. This is the portfolio with the highest overall preference score.

#### **The actors involved in the PAS design process are:**

The clients (C) are the CRE manager and the responsible manager, the actors (A) are the facilitator, system engineer, internal and external stakeholders, the transformation process (T) is the formulation of the program of requirements and the design of new real estate portfolios, taking into account the individual weltanschauung (W) of the actors. The owner (O) of the real estate often is the own

organization or if buildings are rented a real estate investors. The environment (E) often will be determined by the organization itself including a variety of users of the space. (see paragraph 3.1.15 for these CATWOE structure of actors).

### **The system boundaries**

The PAS design management system as a human system generates strategic plans. The first boundary decision concerns the phases of a management process. The PAS design management model is limited to the diagnosis and design phase and does not include change (execution and use) phase at the end.

The second boundary is determined by the responsible manager often together CRE manager; they determine what the focus. The focus often is a particular real estate problem, for instance a type a space (lecture halls), a specific activity (lectures for large audiences). The third boundary will be jointly determined by the stakeholders. Since the PAS is a goal-oriented and as such a prescriptive and normative model where the stakeholders determine the goal, i.e. norm. They determine which aspects will be included in the model or not and thereby, interactively during a PAS process set systems boundaries.

### **The organizational aggregation level of the actors**

The PAS design management system operates on the strategic level of an organization and operates over the total span of the organization. So the actors involved in this system are grouped according the organization's structure: departments, management, board, users, ... This defined the aggregation level of the PAS management system.

### **The sub systems**

The PAS design management system itself is an sub-aspect-phase-system (De Leeuw, 2002, 103-104) of the overall organization system as presented in [Figure 9.7](#): it concerns the accommodation of the organization. Based on the function of the PAS design and decision management system it is divided in four subsystems: steering, programming, modeling and design subsystem.

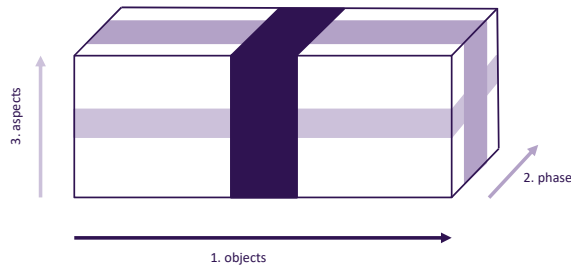

FIG. 9.7 Type of system Note adapted from De Leeuw, 2002, p. 103

### Model language

The PAS design, decision and management system used three different model languages. Firstly, the PAS system is expressed in De Leeuw’s SU/SS system language where SU stands for the steering unit and SS for the steered system (De Leeuw, 2002, p. 155 as explained in paragraph 3.1.14). Secondly, the PAS system as a human activity system is expressed in root definitions using CATWOE (Clients, Actors, Transformation, Weltanschauung, Owner, Environment as shown in paragraph 3.1.15). Thirdly, the PAS management system uses the structure of problem solving and design methodology.

Based upon these features the structure of the PAS design, decision and management system is described. PAS management system consists of the following four related and nested subsystems. Subsystems of a general PAS system are production systems since they produce something:

- 1 The PAS steering subsystem for the organization of an operational PAS design management system;
- 2 The PAS programming subsystem for the generation of program of requirements for the new accommodation and the selection of an optimal design alternative;
- 3 The PAS modeling subsystem for the generation of a mathematical model for the new accommodation;
- 4 The PAS design subsystem for the generation of multiple design alternatives for the new accommodation.

The relationship between these subsystems is shown in [Figure 9.8<sup>75</sup>](#). The subsystems are connected by arrows, where one arrow represents the steering measures from

---

<sup>75</sup> PAS as a human activity system could also have been expressed in a more loose arrow system (De Leeuw, 2002), this is not done due to PAS’s formal and normative character.

the steering unit to the steered system and the other arrow the information from the steered system to the steering unit.

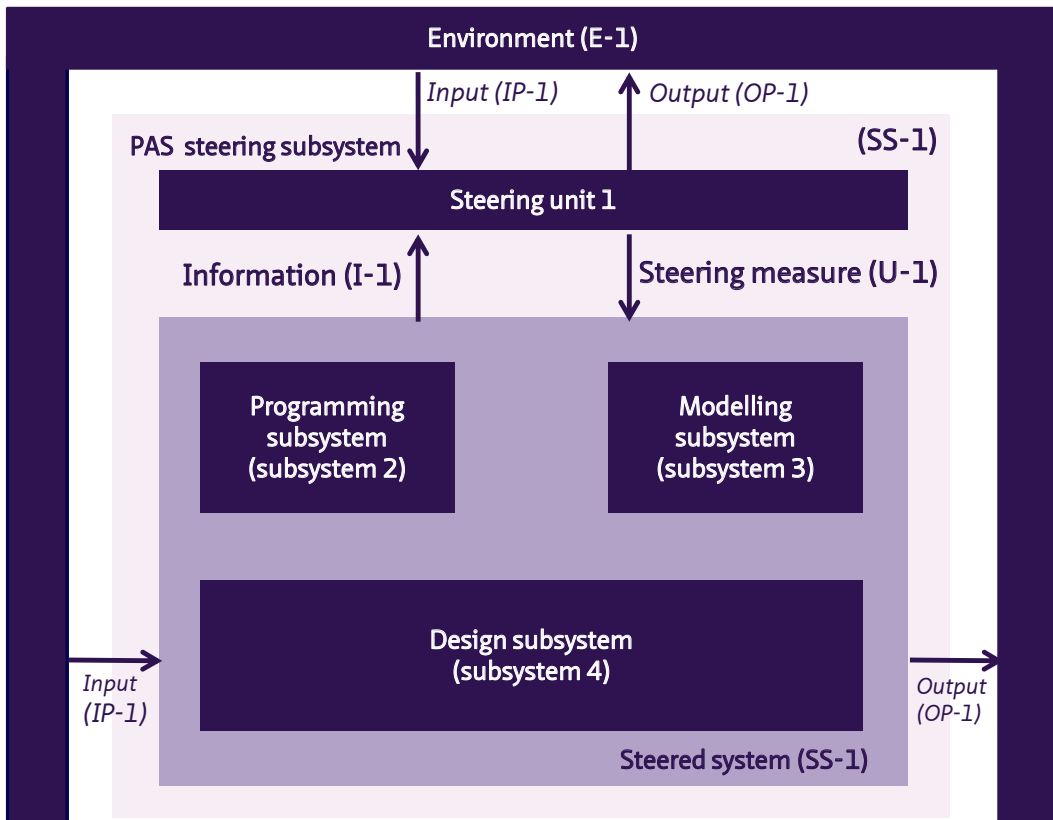

FIG. 9.8 Relationship between the four PAS management subsystems

In the PAS steering subsystem the stakeholders from the organization that will execute the PAS is determined. This group is the steering unit of this steered system. The steered system is the combination of the three other subsystems. In the second subsystem, the so-called *programming subsystem*, the stakeholders define the program of requirements. This program is the output of this subsystem and functions as the input for the third subsystem. In the third subsystem, the so-called *modeling subsystem*, a mathematical model of the situation as described in the program of requirements, is made by the systems engineer. The mathematical model is the output of subsystem 3 and functions as the input for subsystem 4. In the subsystem 4, the so-called *design subsystem*, the stakeholders design solutions in the

mathematical model that will help them solve the problem, i.e. reach the objectives that are defined in the program of requirements. The output of this subsystem is the best solution that can be designed, which is the new input for subsystem 2. In subsystem 2, the stakeholders then either approve or disapprove of this solution and if needed change their information accordingly, which will be new input for subsystem 3. The cycle between subsystems 2, 3 and 4 will be repeated until a solution is approved.

The four PAS subsystems satisfy the conditions for effective steering as defined by De Leeuw (2002, pp. 157-159). The conditions are addressed in different subsystems (see [Table 9.1](#)).

TABLE 9.1 Description conditions related to the four PAS systems

System Conditions	Steering subsystem	Programming subsystem	Modeling subsystem	Design subsystem
1. Goal function of the sub system	To generate / set up the PAS management system and determine the steering unit for the following subsystems.	To generate objectives, problems, decision variables, preference curves and weights	To calculate feasible solutions and partial as well as the overall preference score	To design feasible solutions
2. Model of steered system		Is evaluated based on the understanding of the decision variables as set in this system	Is built in this system	Is evaluated based on the results achieved in this system
3. Information about environment and state of the system		Serves as input in this system	Serves as input in this system	
4. Sufficient steering measures			Each unique design variables has an intervention (steering measure) which are defined in system 3	The steering measures are evaluated during the use of the model in the design system. The stakeholders can add interventions.
5. Capacity information processing		Can be important in this system	Is important in this system	Is important in this system



### 9.3.2 PAS steering subsystem

The *root definition* of the first subsystem is to set up the process organization that will execute the PAS process. The subsystem is graphically presented in [Figure 9.9](#). A PAS process starts when the CRE manager and/or the responsible manager often have acknowledged the existence of a specific CRE alignment problem. They subsequently inform the other party, and the process formally starts when the responsible CRE manager selects a facilitator to start and lead the PAS process. If the CRE manager decides to start a PAS process, the responsible manager thereby acknowledges that the subsystem is fully transparent and that the stakeholders are designers and decision makers.

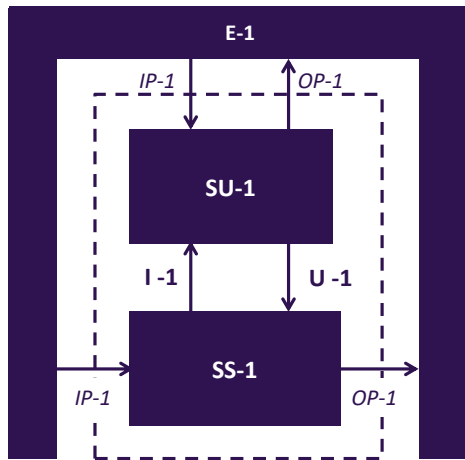

FIG. 9.9 PAS set up subsystem

The *steering unit* in this subsystem consists of the responsible manager and the PAS facilitator. They are responsible to set up a PAS process. The *steered system*<sup>76</sup> in the PAS set up subsystem is the process organization which consists of the relevant stakeholders. The *steering measures* from the steering unit to the steered system are the selection of stakeholders and the weights between the stakeholders. The *information* from the steered system to the steering unit is their acceptance of their role in the process and if needed a suggestion to add other relevant stakeholders. The steering unit and the steered system can consist of internal or external stakeholders which are related to the real estate problem situation. The *environment* of the system is their own organization as well as the external environment to the organization which can be relevant to the PAS process depending on the specific problem in this process. The *input* in this subsystem is the real life system of each of the selected stakeholders, including the current knowledge of their organization and it's environment as well as a the problem at hand. The *output* in this subsystem is the PAS process organization and a preliminary problem description. The steering unit of this subsystem is also the steering of the whole system.

The PAS set up subsystem is explained in [Table 9.2](#).

TABLE 9.2 Description of PAS set up subsystem

System	1	Description
Steering Unit	SU-1	Responsible manager and PAS facilitator
Steered System	SS-1	PAS organization(including the steering unit) consisting of relevant stakeholders that will execute subsystem 2, 3 and 4
Steering measures	U-1	Selection of stakeholders, the intra stakeholders (groups) weights and planning
Information	I-1	Acceptance of their role in the PAS process and possible suggestions to add other relevant stakeholders
Environment	E-1	Organization and its external environment
Input	IP-1	Real life system of each stakeholder and their current knowledge/understanding of the organization, its environment and/or the problem at hand
Output	OP-1	PAS steering unit, organization and a preliminary (vague) problem description

<sup>76</sup> De Leeuw (2002, p. 155) indicates that when using the SU/SS configuration one also needs to play the SU/SS game, for instance by changing the roles between the SU and the BS. By using the BU/SS game is it possible and necessary with a relative simple image of the SU/SS to capture a pluralistic view on the system, if the game is played creatively and with reason. This means that while most of the activities will be performed by the SS the SU will also perform activities. Together they will produce the output of their system.

### 9.3.3 PAS programming subsystem

In this section, the programming subsystem is reticulated (see [Figure 9.10](#)). The *root definition*<sup>77</sup> of this subsystem is to transform (T) a vague problem situation into a well described problem (De Leeuw, 2002, pp. 294-296). The transformation to a well described problem is done by the selected stakeholders (A) in a separate interview with the facilitator (A). If a stakeholder serves as a representative for a particular stakeholder group in their organization, they need to ensure that their input represents the stakeholder group (E) and that they then inform them about the (results of the) process. The programming subsystem is graphically presented in [Figure 9.11](#) and consists of multiple programming systems, one for each stakeholder. This means that there are as many 2<sup>nd</sup> subsystems as there are stakeholders in the process.

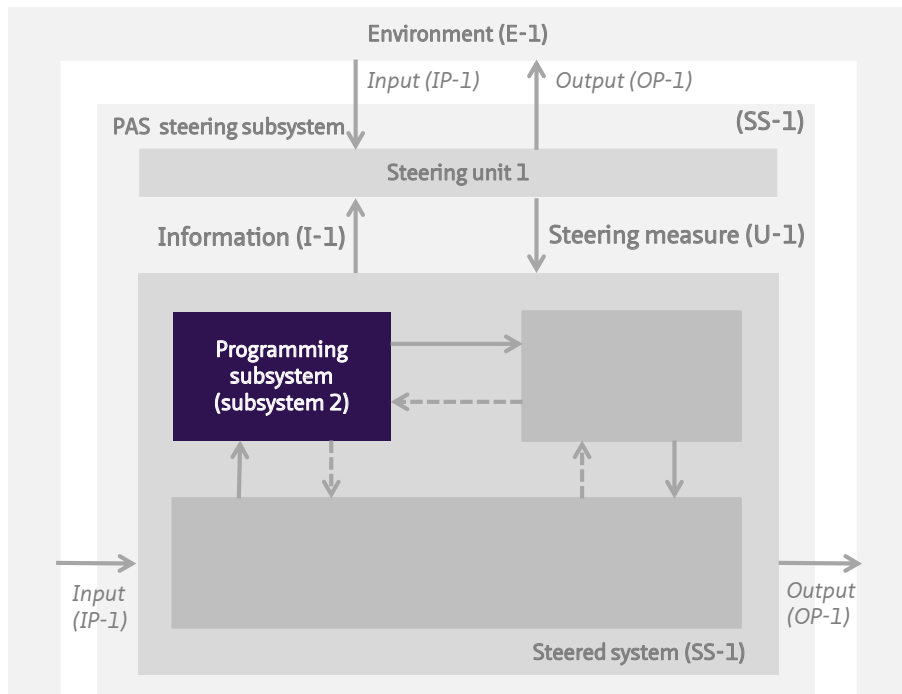

FIG. 9.10 Reticulation of programming subsystem

<sup>77</sup> In the root definitions of this subsystem and the following subsystems, the owners (O) and the weltanschauung (W) have not been mentioned, because this is already done in system 1.

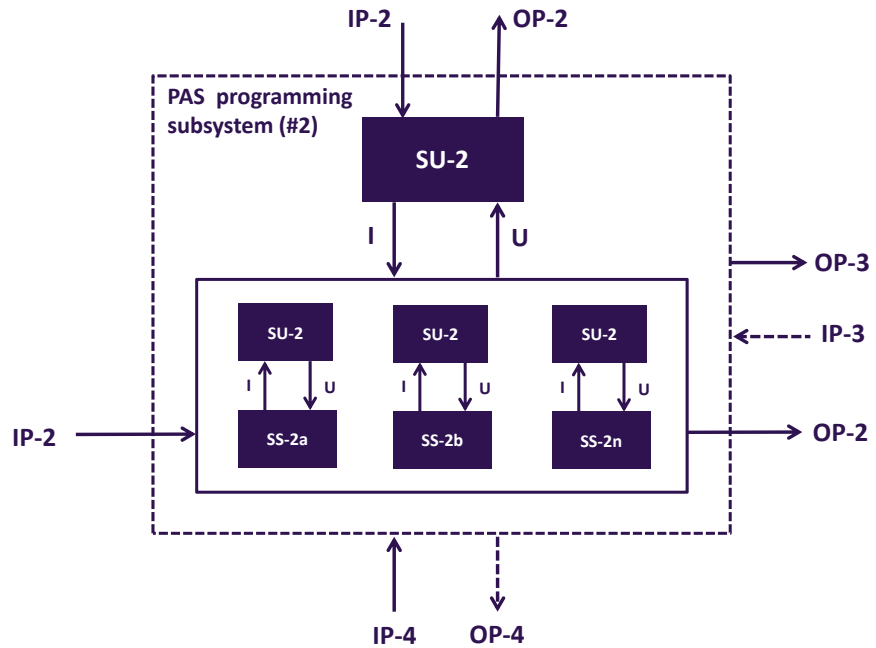

FIG. 9.11 PAS programming subsystem

The PAS programming subsystem is explained in [Table 9.3](#).

TABLE 9.3 Description of programming subsystem

System	2	Description
Steering Unit	SU-2	Facilitator (equal to the SU in subsystem 1)
Steered System	SS-2	Each stakeholder has its own version of subsystem 2 (2a, 2b to 2n)
Steering measures	U-2	Explanation of PAS, interview questions for step 1 to 4 of the PAS and a log of all approved information.
Information	I-2	Answers to interview questions as input for steps 1 to 4
Environment	E-2	Organization and its external environment (equal to E1)
Input	IP-2	Real life system of each stakeholder and the current knowledge of the organization and its environment and/or a problem at hand (equal to IP1 )
		From subsystem 3: model
		From subsystem 4: the best alternative (step 5)
Output	OP-2	To subsystem 3: Result PoR (step 1 to 4)
		To subsystem 1: Approved alternative (step 6): PAS process ends

In this subsystem, the output is a program of requirements which serves as input for subsystem 3. The subsystem is iterative, as shown in the flowchart in paragraph 4.6. Part of the iteration is that the stakeholders individually approve or disapprove the design alternative that has been generated in subsystem 4. If they disapprove of the solution, they individually need to change (part of) their input for subsystem 3. The cycle between subsystem 2, 3 and 4 will be repeated until an alternative is approved by each of the stakeholders.

The steering unit is the PAS facilitator and the facilitator steers both the whole programming subsystem and is the SU in each of the steered systems. The steered system consists of all stakeholders individually, therefore multiple representations of this steered system are made, one for each stakeholder. The steering measures in this subsystem are threefold: (1) an explanation of the PAS to familiarize the stakeholders with this new approach, (2) interview questions and (3) a log of the information given, as well as the changes during the process. The information from each of the steered systems, i.e. 2a-n, to the steering unit are the answers to the questions and the approval of answers in the log. Next to that, the steered system approves the best alternative, i.e. with the highest overall preference score (output subsystem 4 the design subsystem). The input from the environment to this subsystem is equal to the input in the subsystem 1, namely the real life system of each stakeholders and the current knowledge of the organization and its environment and/or a problem at hand. All stakeholders receive the same input from subsystem 3 (the model) and subsystem 4 (the best alternative real estate portfolio). The output of this subsystem is twofold; in the earlier stages of the process it is the approved log and later on, it is the approved alternative. When all stakeholders have approved their own log, the facilitator can proceed to subsystem 3, the modeling subsystem, where the results of step 1 to 4 serve as input. Later on in the process, after subsystem 4, the design subsystem, each stakeholder separately needs to approve the best alternative in step 5. If this best alternative is approved by all stakeholders then this alternative is chosen and step 6 is executed.

The flowchart of this subsystem expressing the related stakeholders & activities, steps and models is shown in [Figure 9.12](#).

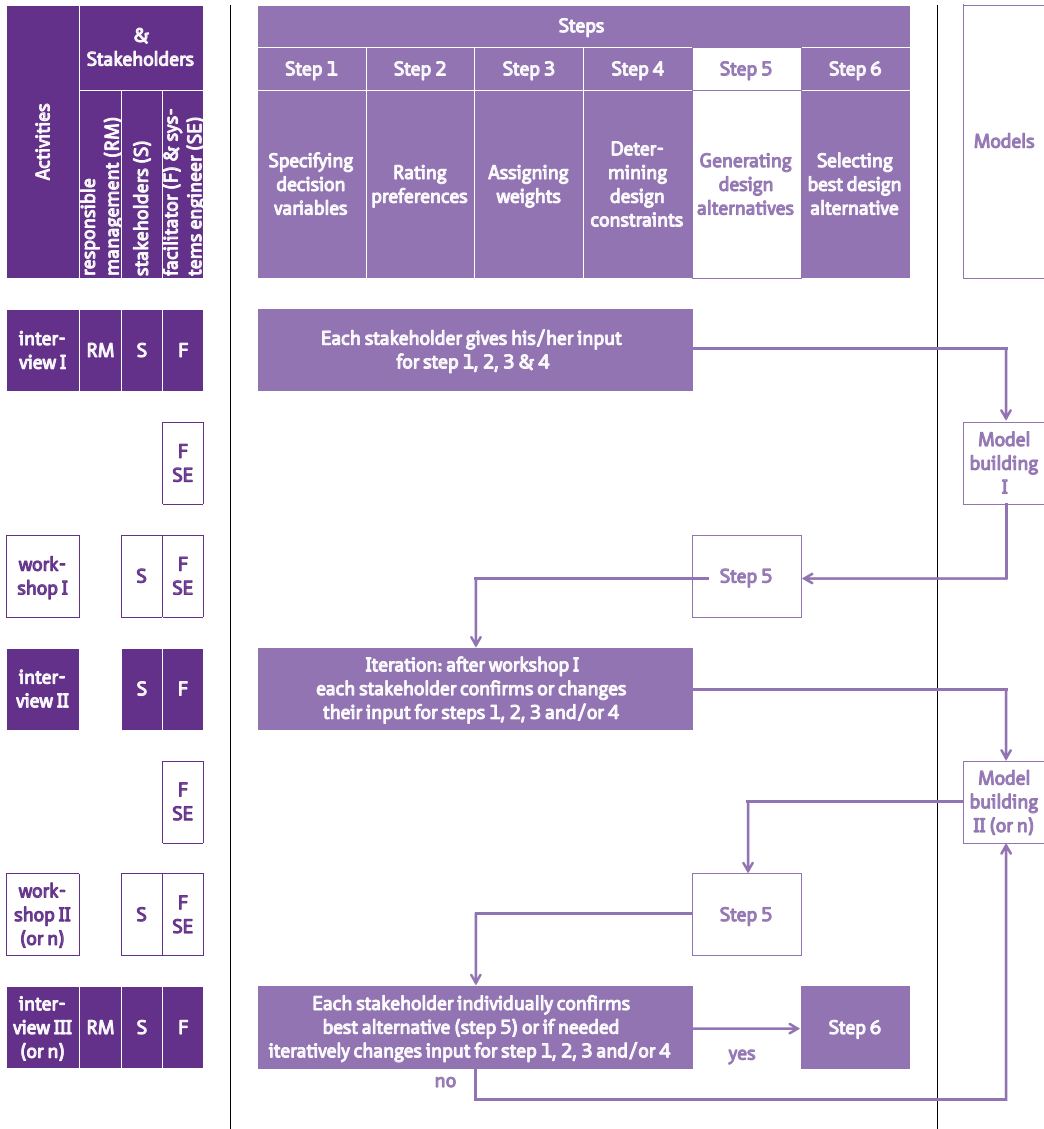

FIG. 9.12 Flowchart programming subsystem

### 9.3.4 PAS modeling subsystem

In this section, the modeling subsystem is reticulated (see [Figure 9.13](#)). In this subsystem, the *root definition* of the process is that the subsystem engineer (A), under guidance of the facilitator (A), builds a mathematical model (T) based on the program of requirements (as defined in subsystem 2) for the stakeholders (C), so they can use it to design alternatives (in subsystem 4). The facilitator, at any time, can approach the stakeholders (C) or other parts of the organization (E) to collect information needed to build the model. The subsystem is graphically presented in [Figure 9.14](#).

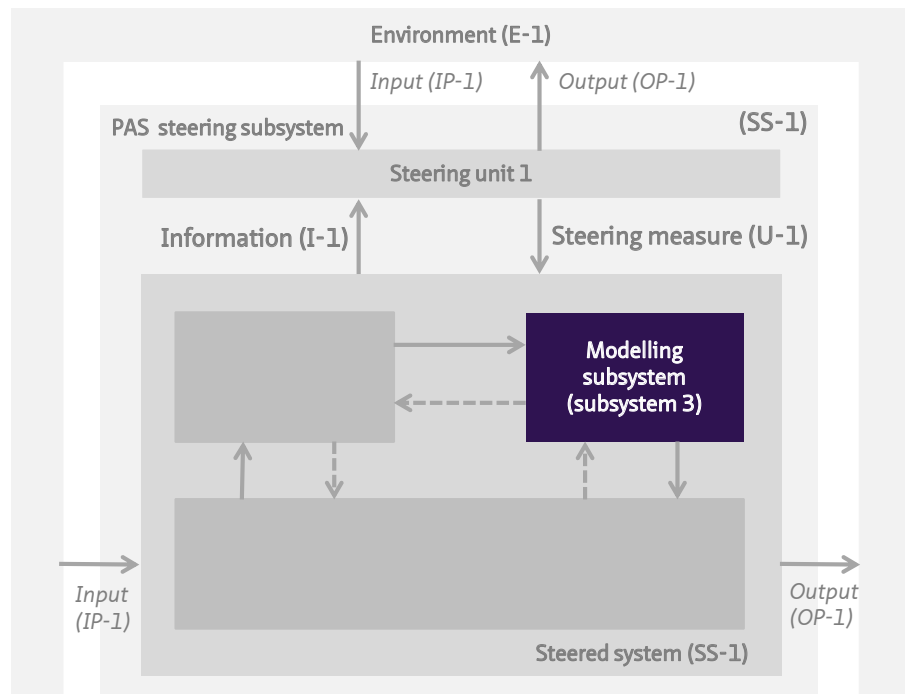

FIG. 9.13 Reticulation of modeling subsystem

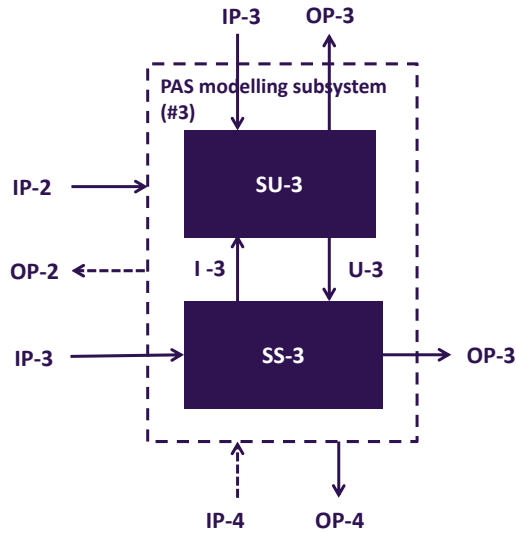

FIG. 9.14 PAS modeling subsystem

The PAS modeling subsystem is explained in [Table 9.4](#).

TABLE 9.4 Description of PAS modeling subsystem

System	3	Description
Steering Unit	SU-3	Facilitator (equal to the SU in subsystem 1 and 2)
Steered System	SS-3	System engineer
Steering measures	U-3	Interventions and relationships between the decision variables, testing and accepting of the model and if necessary clarification of input or additional information and/or data
Information	I-3	Draft model(s)
Environment	E-3	Stakeholders from subsystem 2 (equal to the SS in subsystem 2) or members for the CRE department for input about the objects.
Input	IP-3	From subsystem 2: Results of step 1 to 4 or changes results of steps 1 to 4 after using the model in subsystem 4.
		From subsystem 4: Modeling errors, i.e. misunderstandings of the relationships between the decision variables or modeling mistakes
Output	OP-3	To subsystem 2 and 4: Model (equal to input for subsystem 4) and a presentation of the model.



The steering unit is the PAS facilitator and the steered system is the system engineer(s). The steering measures in this subsystem are threefold: (1) defining the possible interventions as well as the relationships between the decision variables, (2) testing the model if it fulfills the requirements and (3) during the process provide clarification and/or additional information or data. The information from the steered system to the steering unit is twofold; (1) draft models and (2) clarifying questions. The input to this subsystem is the output of subsystem 2 and 4 (OP-2 and OP-4). After the first interview round in subsystem 2 the results of step 1 to 4 are known; the decision variables, preference curves, weights as well as the boundary conditions. After the use of the model in subsystem 4 and the subsequent interviews in subsystem 2, any of the given input is allowed to be changed. After the use of the model in subsystem 4, it is possible that modeling errors have surfaced. Errors can be either misunderstandings when defining the interventions and/or the relationships between the decision variables or modeling mistakes. The output of this subsystem is the mathematical model, which is the input for subsystem 4, the design subsystem. The model can also be given to the different stakeholders to use the model themselves, outside the workshop in order to increase the acceptance of the system.

The flowchart of this subsystem expressing the related stakeholders & activities, steps and models is shown in [Figure 9.15](#).

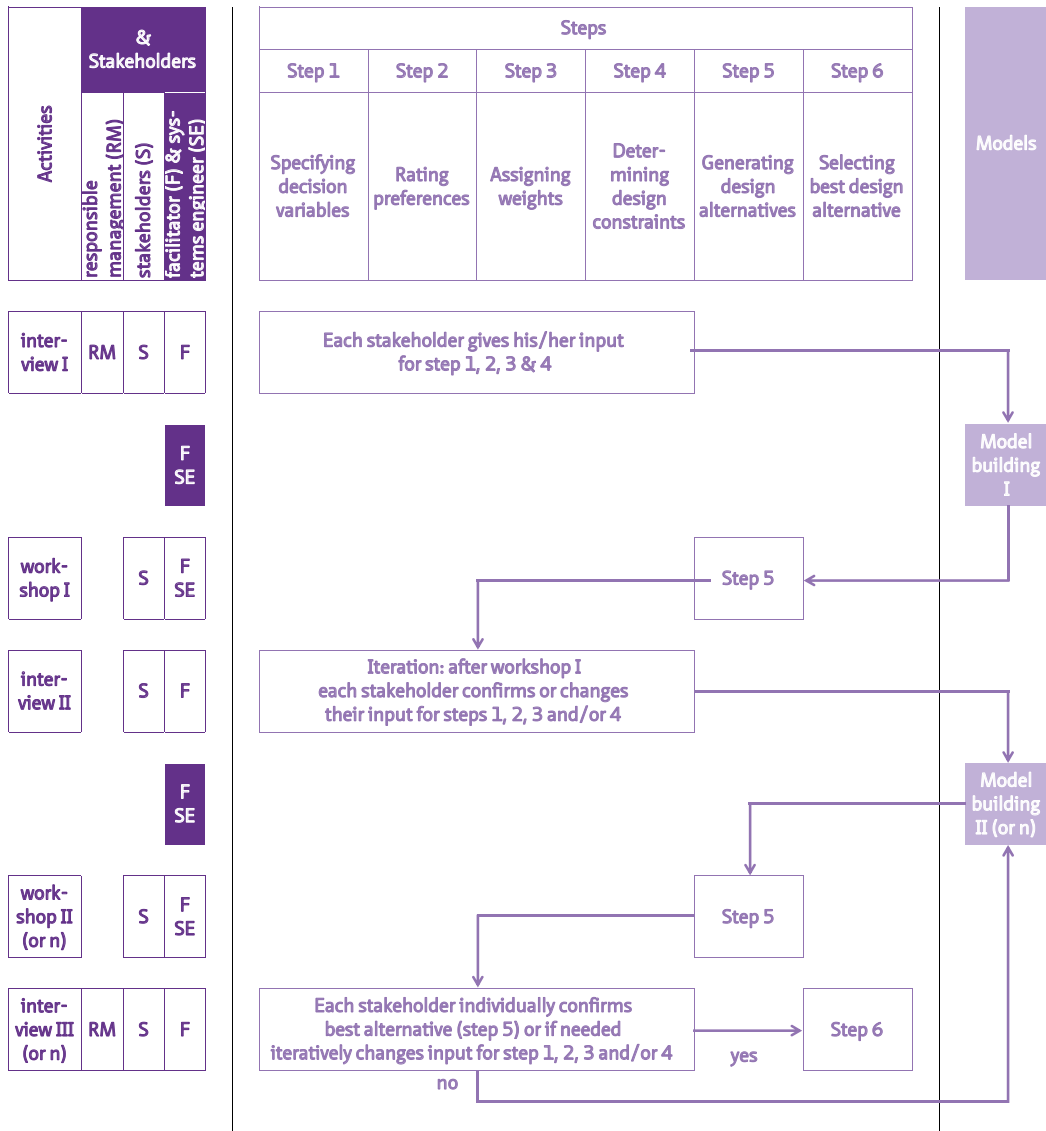

FIG. 9.15 Flowchart modeling subsystem

### 9.3.5 PAS design subsystem

In this section, the design subsystem is reticulated (see [Figure 9.16](#)). The *root definition* of the design subsystem is that the stakeholders (A & C), in a series of workshops under guidance of the facilitator (A), design alternative corporate real estate portfolios (T) in the mathematical model (output from subsystem 3) to achieve the objectives that are defined in the program of requirements (from subsystem 2) optimally, and therefore add most value to the responsible manager of the organization (C). If a stakeholder serves as a representative for a particular stakeholder group in their organization, they need to ensure that their input represents the stakeholder group and that they inform them (E) about the (results of the) process. The output of the this subsystem is the best alternative CRE portfolio, which is then input for subsystem 2.

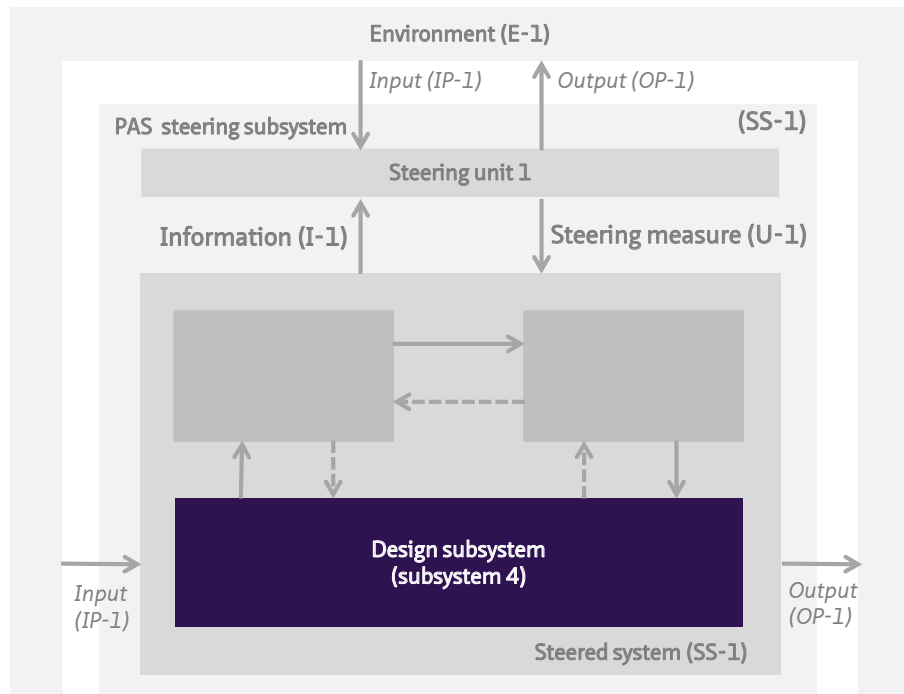

FIG. 9.16 Reticulation of design subsystem

The design subsystem is graphically presented in [Figure 9.17](#).

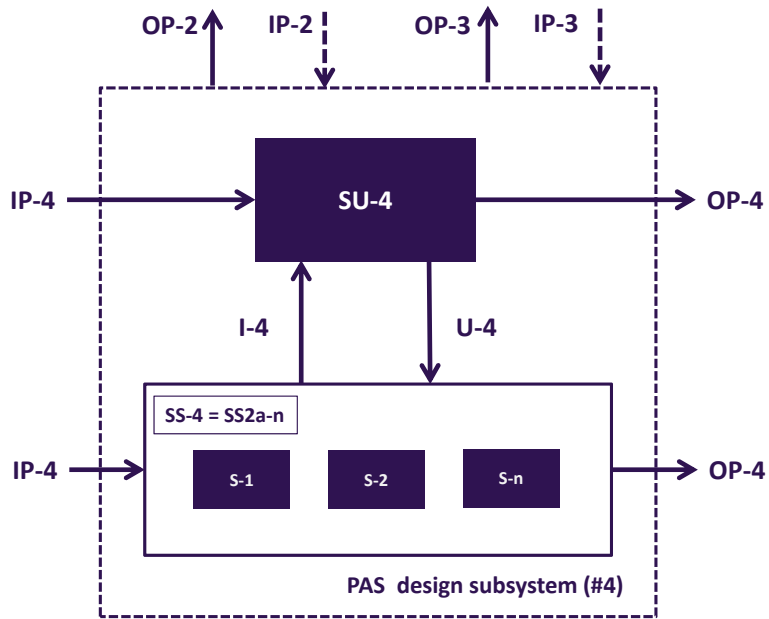

FIG. 9.17 PAS design subsystem

The PAS design subsystem is explained in [Table 9.5](#).

TABLE 9.5 Description of design subsystem

System	4	Description
Steering Unit	SU-4	Facilitator (equal to the SU in subsystem 1, 2 and 3) (and the system engineer ( SS in the 3 <sup>rd</sup> subsystem)
Steered System	SS-4	All stakeholders in the pilot study (equal to the SS in the 2 <sup>nd</sup> subsystem)
Steering measures	U-4	Instructions on the working of the model, including the possible interventions for the objects and the back end of the model
Information	I-4	Generated alternative real estate portfolios
Environment	E-4	Organization and especially the groups that the stakeholders represent as well as the organization's external environment
Input	IP-4	From subsystem 2: program of requirements and an updated log From subsystem 3: the mathematical model From subsystem 3: i.e. the overall preference score of the current real estate portfolio based on their requirements
Output	Op-4	To subsystem 2: best alternative real estate portfolio that was generated To subsystem 3: possible modeling errors

The steering unit of this subsystem is the facilitator in combination with the system engineer. The steered system consists of all stakeholders as a group. The stakeholders design alternatives in the mathematical model under guidance by the system engineer and facilitator. The steering measures in this subsystem are the instructions about the mathematical model, including the interventions that are available in the mathematical model and their subsequent effects. The information from the steered system to steering unit are the designed alternatives. The input from the environment to this subsystem is equal to the input in subsystem 1, namely the real life system of each stakeholders and their current knowledge of the organization and its environment and/or a problem at hand. All stakeholders take their own input from subsystem 2 to subsystem 4 and have the same input from subsystem 3 about the model available. The output of this subsystem is twofold; in the earlier stages of the process stakeholders can detect modeling errors (to subsystem 3) and the best alternative real estate portfolio (to subsystem 2).

The flowchart of this subsystem expressing the related stakeholders & activities, steps and models is shown in [Figure 9.18](#).

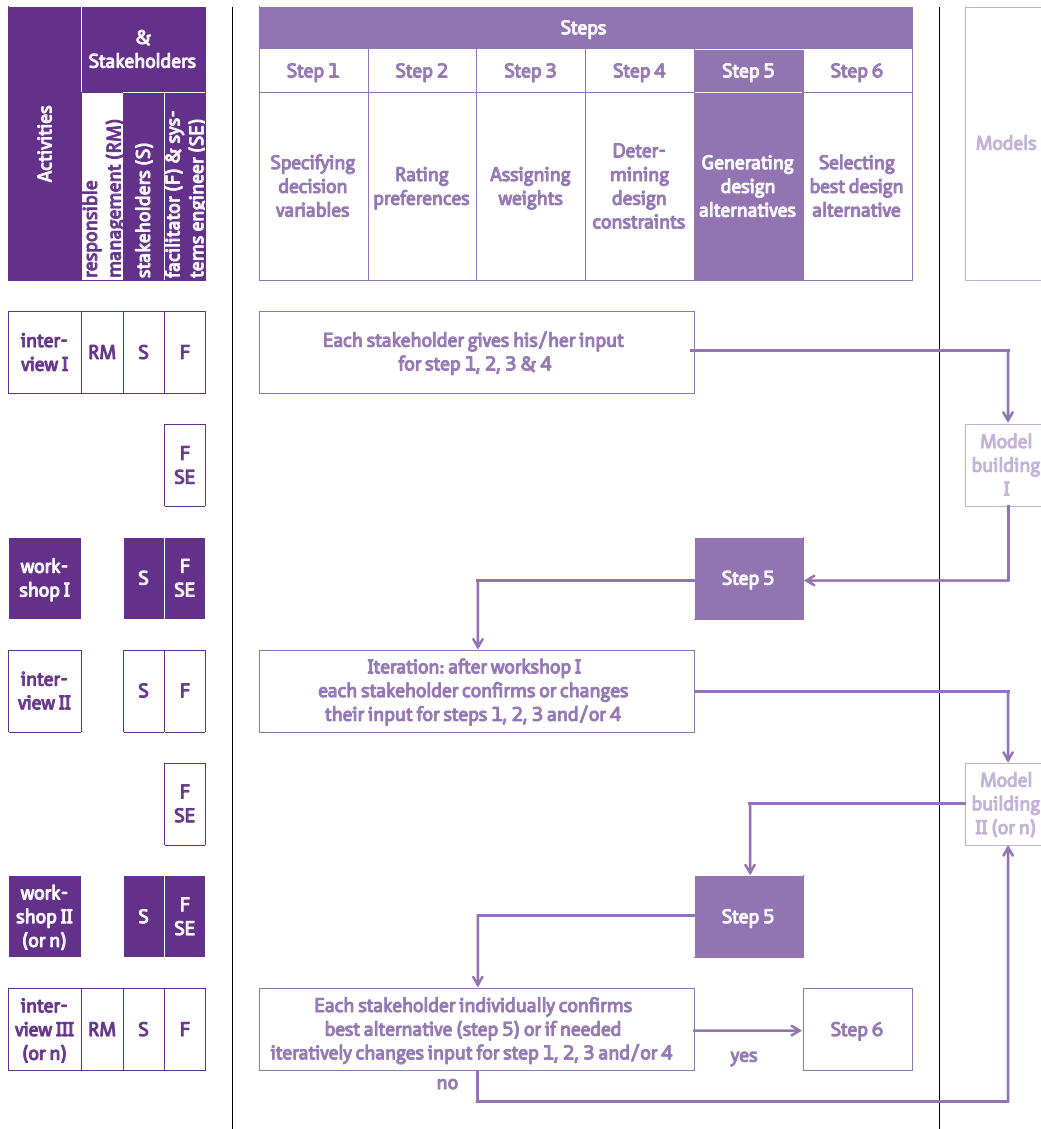

FIG. 9.18 Flowchart design subsystem

## 9.4 Conclusion

---

PAS has initially been intended to be add-on to other CRE alignment models. Two examples have been shown to demonstrate that this is feasible for the PAS steps. However, using the PAS method as add-on in these models creates managerial and methodical difficulties if PAS components *stakeholders & activities* and *model* also need to be taken into account. The structure of these models is often not congruent with the structure of the PAS method.

Therefore, PAS has been transformed into a management system, following De Leeuw (2002). A PAS management system is valuable because it represents PAS from the organizations' point of view. This management system consists of four systems: PAS steering system; PAS programming system; PAS modeling system; and PAS design system.

In the PAS steering system the organization that will execute the PAS is determined while the other three systems are all a part of the steered system. The PAS Set up system consists of acknowledging a CRE alignment problem and formally starting a process to solve the problem together with the involved stakeholders under guidance of a facilitator and systems engineer. The input is the real-life system of the current stakeholders, including their current knowledge of the organization and its environment. The output of the system is a preliminary problem description. The PAS Programming system is defined as the transformation of a vague problem situation into a well-defined problem. The transformation to a well described problem is done by the selected stakeholders in interviews with the facilitator. The output of the system is a program of requirements. In the PAS Modeling system the system engineer and facilitator build a mathematical model based on this program of requirements. In the PAS Design system the stakeholders design alternative real estate portfolios in the mathematical model to solve the problem, i.e. reach the objectives that are defined in the program of requirements. The programming, modeling and design system as well as the steering measures and information flows between them is the core of the system. For each system the steering unit, steered system, the steering measures and information between them is described as well as its input, output and environment. All four systems are congruent.

PAS has also been described from a design methodology point of view to show how all parts of the system are connected. PAS is displayed in four figures that function as a map and shows how the different parts are connected.

