

7 TECH. Transportable Emergency Cardboard House

FLe²XARD the way to go! [1]

§ 7.1 Introduction.

TECH: Transportable Emergency Cardboard House was a project involving shelters for people in difficult housing situations.

The TECH project was based on previously conducted research. The fundamental research on paper, presented in Chapter 2, focused on the material itself, its mechanical properties, its chemical and physical structure, its production methods and elements mass-produced by the paper industry. Next, research was conducted on the applications of paper products in design and architecture. The sixteen realised structures, in which paper was employed as a building material, were analysed for their structural systems, the paper products used, the connections made between the structural elements, the connections with the ground, the impregnation methods deployed and the design and implementation processes involved. Lastly, the paper emergency structures realised in the form of prototypes, in which different paper products and structural systems were examined, resulted in the further guidelines for paper emergency shelters presented in Chapter 6.

A column-and-beam structural system was chosen as it is a simple system that can be built quickly without professional construction workers and without special equipment and tools.

The chosen structural system consists of slender elements in the form of columns and beams. To build that system cardboard U- and L-shapes were used.

Paper tubes, which were an alternative for the U- and L-shapes, are hard products to connect to other types of building components due to their geometry. Either the paper tubes are placed inside a building, taking up space that may already be limited, or

they are incorporated into the envelope, where they are subject to external conditions. For this reason, it is more practical to use paper products such as L- and U-shapes as structural elements.

The TECH project was targeted at forcibly displaced and homeless people. Please refer to Chapter 5 to read more research on motivations and guidelines for emergency and relief shelters.

The number of forcibly displaced people was estimated to be 65.6 million at the end of 2016. [2] Forcibly displaced people are people who had to flee their houses and cities because of persecution, conflicts, generalised violence or human rights violations. Three different categories of forcibly displaced people can be distinguished:

- Internally displaced people (IDPs)
- Refugees
- Asylum seekers

The number of homeless people living rough or in shelters or hostels provided by aid organisations in developed countries was 1,777,308 in 2015. [3]

Asylum seekers who come to Europe but are not granted refugee status run the risk of becoming homeless.

Each of the aforementioned groups requires different types of support, including housing. As far as accommodation is concerned, the support they receive may come in the form of mass shelters, dispersed settlements, hosting families or spontaneous or planned camps.

TECH is an acronym for Transportable Emergency Cardboard House. The designations 'TECH 01', 'TECH 02' and 'TECH 03') refer to successive versions of the project where structural parts and building components and impregnation techniques were improved.

There are three generations of TECH. While TECH 01 was prepared as an unbuilt project and only the prototype of the wall structure was executed, TECH 02 and TECH 03 were executed as 1:1 scale prototypes. TECH 02 was exhibited at the campus of TU Delft's Faculty of Architecture for several days. TECH 03 was built in September 2016. Since then it has been at Wroclaw University of Science and Technology's

Faculty of Architecture, where it is exposed to natural conditions and changing weather conditions.

In general it can be said that TECH is a group of solutions for emergency and temporary housing, which can be used to serve people in difficult housing situations. However, TECH 03, also known as ‘the House of Cards’, may also serve as a commercial structure. It can be used as a garden or summer house, as an extension of existing buildings, shed, temporary office building, hotel room or storage space for events like trade fairs, exhibitions, major sporting events, etc. TECH 03 was designed to meet European architectural standards, especially with regard to thermal insulation.

This chapter is mainly concerned with the structural system of the TECH solutions, as well as the paper products used as building components, the usability and feasibility of the shelters and their production methods.

§ 7.2 Design methodology

The process of designing, researching and developing emergency shelters made out of paper elements and components was divided into two phases (see Fig. 7.1). The first phase consisted of fundamental and technical research, which also encompassed material research, an examination of the opportunities and risks presented by the use of paper products in design and architecture, and research on the social aspects of emergency and relief shelters. The second phase (practical research) included research by design, engineering, prototyping and tests conducted to tests on mechanical properties of the material as well as impregnation methods.

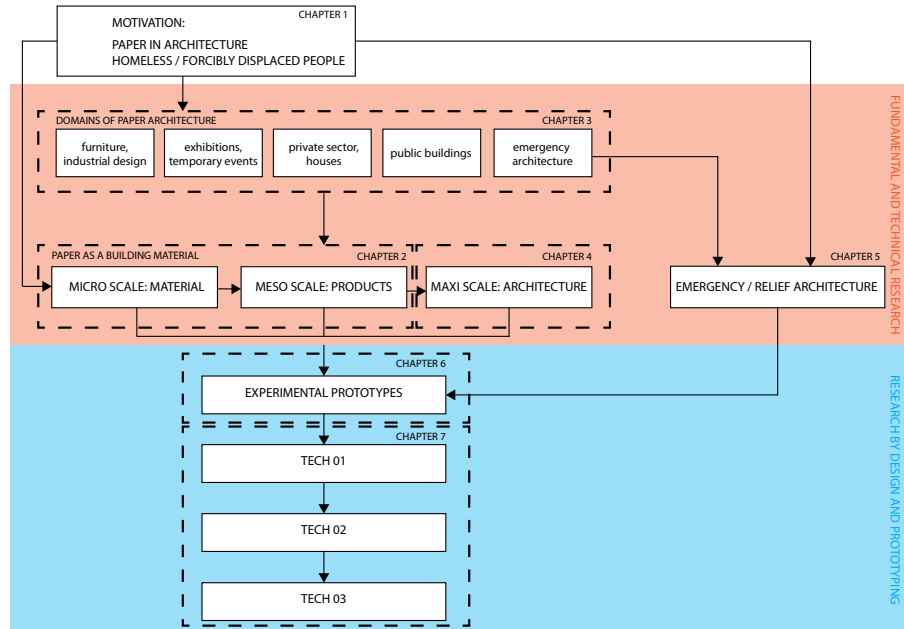

FIGURE 7.1 Research scheme

The basic motivation for the research and development undertaken as part of this project was the hypothesis that paper is a suitable material for emergency shelters on account of its cost-efficient production, availability, eco-friendliness and structural and mechanical properties.

The main goal of the process was to develop a product which would satisfy all the requirements for emergency situations, and would provide the market with an adequate emergency shelter that would improve the living conditions of victims of natural and man-made disasters and homeless persons.

The project was carried out in accordance with the Methodology of Product Development in Architecture proposed by Mick Eekhout. [4] Product development as described by Eekhout is based on organograms. Organograms can be used as a holistic approach to three different types of building products: standard products, system products and special products.

Standard product – standardised and produced independently of the designers. The architect only gets to decide how to position the product in space (topology) – i.e., tiles, bricks, bolts and nuts.

System product – developed as an integral system and built from functional elements and components. A system product can be applied to different projects. Its colours or dimensions may change, but the technical core of the system will never change. System products are intended to be applied to different projects.

Special product – a product or component particularly designed for a certain building project. Sometimes special products are made up of standard and system sub-products.

There are three main types of products, as well as four transitional types:

- **STANDARD PRODUCTS**
Systematised standard products
Standardised system products
- **SYSTEM PRODUCTS**
Special system products
Systematised special products
- **SPECIAL PRODUCTS**

An architect has 100% influence on special products and 0% influence on standard product. For producers it is the other way around.

Cardboard products like paper tubes, corrugated boards, honeycomb panels and U- and L-shapes are typical standard products produced in large quantities by factories. The exact quantity depends on the factory and the type of machinery used. Many factories produce thousands of tonnes of corrugated cardboard per day.

As TECH is a structure consisting of several components which are in turn composed of standard products, it can be assumed that TECH is a special product.

Organograms are a reflection of the sequence of activities undertaken during the design, research and development process. They are used as a model for smooth designing and developing processes (see Fig. 7.2). Organogram describe sequences

of serial processes (one after the other) or parallel processes (one next to the other – concurrent engineering). The organogram used on the TECH project involves eight steps.

The first step is defining the Evaluation Criteria. This helps define exact expectations and when they are expected to be fulfilled. It is possible to return to this stage several times during the process. If no criteria are defined at this stage, researchers will not know if the process, after having gone through several steps, is correct, or whether it will lead to the desired results.

The second step is Aspect Study. During this phase the main problem is sub-divided into several sub-problems. Such problems may be considered autonomous or partly autonomous aspects of the subject, so they can be studied separately. The separated aspects are later combined or integrated into the clusters.

Each cluster of aspects consists of four steps:

- Analysis
- Brainstorming
- Ideas
- Synthesis

The concepts of the various aspects are then combined into a complete product concept.

Once a product concept has been drawn up, it is a time to decide if the resulting product concept is technically feasible. The next step cannot be taken until the feedback is completely positive.

In the organogram presented below, the evaluation criteria and aspect study and analysis were combined into five clusters. The criteria were analysed and studied during the research on material and emergency architecture. Then they were turned into the product concepts and prototypes described in Chapter 6 (called 6.2 CS in the organogram). Next, based on previous research and prototyping, the criteria and aspects were studied and analysed again, which resulted in the concept of TECH. TECH 01 (7.3 TECH 01) was analysed and design of the structure was prepared. Additionally the prototype of the wall component was built. The next generation of the building, TECH 02 (7.4 TECH 02), based on the further analysis of the primary concept design of TECH. After the construction of the TECH 02 prototype, and the evaluation of its structure and details, the final version (TECH 03) was prepared (7.5 TECH 03).

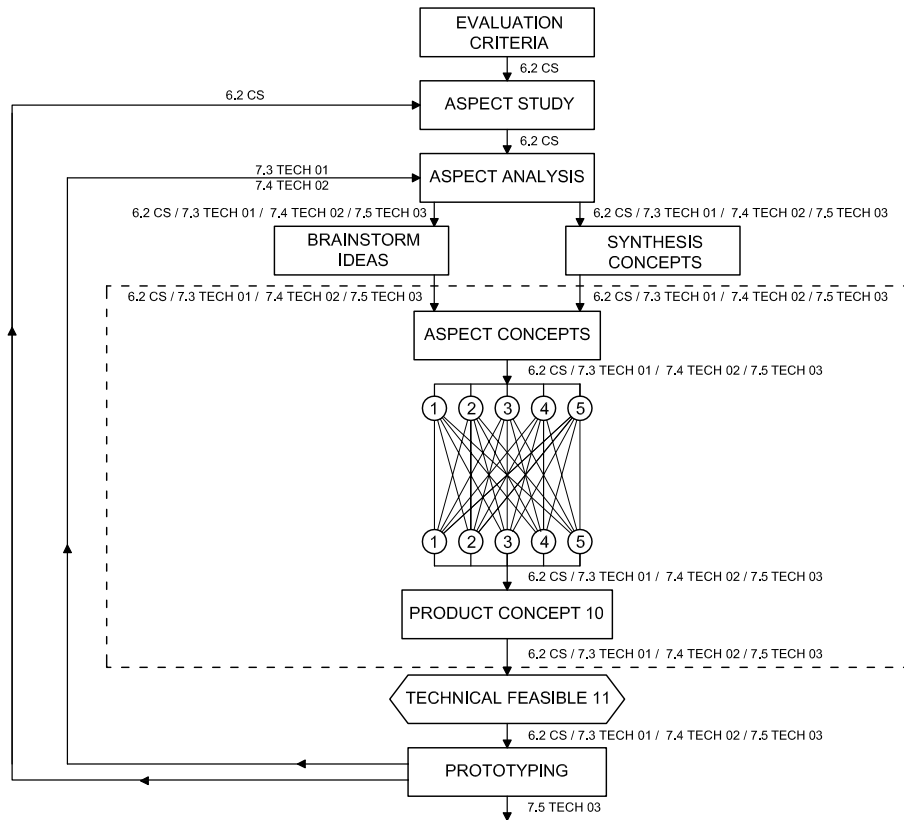

FIGURE 7.2 Organogram adopted for the TECH project

During the work with the organogram, certain sequences create four clusters of related activities:

- Objective / goal
- Analysis and synthesis of aspects
- Product concept
- Evaluation and feasibility

The order of these clusters cannot be altered, but there is a certain amount of freedom within the clusters: the individual activities can be gone through serially or in a parallel

manner. The architect or designer has no influence on the standard products. The only thing s/he can do is decide whether or not to use a certain product.

The organogram for products in architecture consists of five phases:

- Design concept
- Preliminary marketing
- Prototype development
- Final marketing
- Product manufacturing

TECH followed the first three steps.

The preliminary marketing was presented in chapter 5, where the 'target group' and the scale of demands were described.

Specific goals for the project included the following:

- Design parameters (area, dimensions)
- Spatial planning on site
- A flexible structure in terms of layout and further extension
- Project and production of building components and elements
- Building process

In order to achieve goals in architectural projects, several steps have to be undertaken and a process strategy must be adopted. The main steps in the design, research and development strategy are:

- Setting the criteria and aspects of the project (requirements and functions)
- Setting the design objectives
- Preparation of the concept design – project concept
- Technical and material solutions and feasibility
- Prototyping
- Evaluation

These above steps must be evaluated and assessed to ensure that a project has the desired results. If the evaluation is not positive, all parties involved must take a step back and rethink the process.

The criteria and aspects for the Transportable Emergency Cardboard House project were divided into five clusters:

- Design requirements and functions
- Material aspects
- Technical solutions
- Potential for production
- Implementation of the product

DESIGN REQUIREMENTS AND FUNCTIONS	MATERIAL ASPECTS	TECHNICAL SOLUTIONS	PRODUCTION	IMPLEMENTATION
Addressed 'target' group	Elements mass produced by paper industry	Building components and elements	Production process	Storage
Function-focused design	Efficient thermal and acoustic insulation	Structural system: flexible, quick	Costs of the shelter	Transportation
Neutral	Impregnation methods	Connection between the elements and components		Construction (weight of the elements, equipment required)
Size of the shelter	Minimising the ecological burden	Connection with the ground		Simple construction process (no professionals required; quick erection of building)
Flexible layout				
Special layout				
Lifespan				

TABLE 7.1 Five clusters of criteria and aspects for the Transportable Emergency Cardboard House project

Design requirements and functions

TECH is an emergency shelter geared towards people affected by natural and man-made disasters and to homeless people. It is particularly geared towards forcibly replaced people, who are one of the main subjects of this thesis, along with homeless people in developed countries. Both groups were specifically described in Chapter 5. Since this group of people is large and diverse, the shelter should allow for adaptations to local natural and cultural conditions. As the shelter should first and foremost fulfil people's physiological and safety needs, the design should be function-focused. It is advisable to create shelters with simple shapes and straight walls, which will allow users to outfit them with commonly available furniture. However, the shape and structure of the design should allow further development and enlargement of the shelter in the future. The appearance of the shelter should be modest and neutral, so that it will be suited to various cultural backgrounds. Furthermore, the design must

involve building components whose appearance can be modified according to local conditions and traditions. Such modifications may be made by physically modifying building components or by means of printed outer layers to be put on the building components. For example, shelters designed for different regions with different cultural backgrounds may have different types of windows or protection from the sun. In European regions, rectangular shapes are most popular, while in Asian countries the dominating element is a circle, and in Middle Eastern countries it is an octagon. The various versions of Shigeru Ban's Paper Log House are a good example of a shelter adapted to different cultural and climatic conditions (see Sections 4.3.4 and 5.5.5). According to the typology presented in Chapter 5, TECH should be designed as a temporary shelter or temporary house (see Section 5.4). This means that TECH could be used for months or years and its lifespan should be assumed to be one to five years, with a possible extension.

TECH is a product that can replace the standard UNHCR family tent. Therefore, its size should be similar to the typical size of UNHCR's tents. The size of UNHCR's tents is based on the assumption that a family consists of five members, and the minimum requirements are 3.5m² per member of the family. Therefore, tents with an area of 17.5m² are most common. However, families come in different sizes. For this reason, different sizes should be available, and there should be a possibility of clustering several shelters in the event of a bigger family or a need for another function, such as education or healthcare. One of TECH's main goals was to provide a form of shelter that can be easily modified, depending on how much space the users need. The structure of the shelter should allow for rearrangement or reconstruction in several different configurations. Therefore, the structural system should be flexible and consist of elements and components that can be changed, depending on the required layout.

Material aspects

The goal for TECH was to produce a lightweight, low-cost and eco-friendly shelter that would provide sufficient comfort to its inhabitants.

In order to achieve this goal, the author of this dissertation researched products mass produced by the paper industry. As described in Chapter 2, this research mostly comprised five categories of products, which are produced in large quantities: paperboard, paper tubes, corrugated cardboard, honeycomb panels, L-shapes and U-shapes. Each of these products has its own characteristics and can be used as part of a different type of structure. Paper tubes and L-shapes (or U-shapes) can be used as part of frame structures, while corrugated cardboard and honeycomb panels can be applied as filler for the envelope of a building. When paper tubes are used as structural elements, they are hard to combine with other building components, such as walls,

because the circular shape of the tube is at odds with the linear shape of the wall. Paper tubes can also be used as elements of a wall, as in the Paper Log House (see Section 4.3.4). In such situations, paper tubes are placed next to each other. However, this solution results in thermal bridges and loss of energy at the connections between the tubes. Due to their shape, L-shapes and U-shapes are much better suited to being used as a frame structure connected to the walls and roof. The mechanical properties of L-shapes and U-shapes were proved by material tests (see Appendix 1), and their usability in architectural structures was proven in previous attempts and prototypes (see Chapter 6). For this reason, they were the author's material of choice for the frame structure. Wall and roof panels can be made of corrugated cardboard or honeycomb panels, or both. From a thermal insulation point of view both materials (corrugated cardboard and honeycomb panels) show a relatively high level of insulation. The honeycomb panels should not be thicker than 25mm to let the air pockets create insulation cells filled with air.

TECH's floor can be made from both paper elements and timber elements. However, the latter is more suitable in structures that are supposed to have a long lifespan.

Given the enormous number of people who need a temporary shelter or temporary house, the ecological impact of the chosen materials and the way in which they are to be processed are important matters for consideration. While paper can be easily recycled, it is also vulnerable to water and moist. In order to minimise the ecological burden, the material should be impregnated against water and fire in a way that allows further recycling. This can be done by applying the layer of impregnation on the surface of the building component by means of lamination. The laminated layer can be later ripped off, after which the rest of the material can be recycled. Another option is to use a type of varnish that will not prevent the material from being recycled. Impregnation methods should be further researched by a specialist in the field of chemical engineering and paper production.

Technical solutions

Out of the three most common structural systems: rod system, panel system and shell system, the first two are the most suitable for use in temporary shelters and housing. The panel system, which is quick in use and has a small volume when folded down, proved to be very limited in terms of functional flexibility, potential for rearrangement and structural stability. In a panel system the panels should be integrated with load-bearing elements. If a frame system is used it should be filled with insulating panels. The latter solution allows alternating between panels, which means the structure can be adapted to different climatic conditions. The structure should be created in a way that allows its parts to be fixed, replaced or renovated. The shelter should be properly

insulated from the ground. This can be achieved by means of a good insulation layer and by elevating the shelter from the ground. In this case an under-floor air distribution system (UFAD) would be possible. The connection between the building and the ground, by means of concrete feet or ground screws, will allow for UFAD and will minimise the ecological imprint on the terrain. TECH should be composed of prefabricated building elements and components. If they all have similar dimensions, the shelter will be competitively priced, and a flexible layout will be possible. The connection between the elements and components should be easy to allow the shelter to be erected quickly, even by non-professional construction workers.

Production

TECH is a shelter made out of paper elements and components. This means that the paper industry will be involved in its production and that mass-produced products are used. L-shapes and U-shapes, which will be used as a structural frame, are available all over the world, as are corrugated cardboard and honeycomb panels. Such products are staples in the paper industry and are mostly used for packaging purposes. It is vital that certain types of paper products be used, and that their production processes be taken into account. The structural elements of the shelter can be made out of recycled paper, but it is advisable to check the mechanical properties of said paper. The mechanical properties of paper depend on the source material (pulp) and the paper production process used. This is explained in more detail in Chapter 2. The strategy for TECH is to use mass-produced paper products that will be sent to a production factory. The factory will then combine the standard products into building elements and building components. Components such as doors, windows, ventilation grids, ventilation shafts and electrical installations will be ordered from external factories. Where necessary, the products will be impregnated, then combined into building elements or building components. The production process needs to be carefully thought out and planned so that a large number of shelters will be able to be produced. Building components (i.e. the floor components, walls and roof) should be produced parallel, so that the speed of production will be increased and the quality of the components can be checked at the end of the production lines. The costs of the shelter depend on several features, such as its size, structure, floor, connection with the ground, thermal insulation and quantity of the units. However, the final price should be close to or not much higher than the price of existing solutions for emergency shelters.

Implementation

Emergency shelters, as well as temporary shelters and temporary housing, are often needed in large numbers, due to the number of people affected by natural or man-made disasters and the need for an immediate response in the event of a disaster (see

Chapter 5). Therefore, TECH should be produced in large numbers, as well. In order to allow for immediate demand, the building elements and components should be easy to store. This means that the size of the individual building component should be optimised so they can be kept in warehouses without taking up too much room. The size of the components is a factor in transportation, as well. Since transportation costs sometimes exceed the costs of the shelter itself, a careful transportation strategy must be drawn up, allowing various modes of transportation (e.g. shipping containers) to be used to their maximum capacity.

The size and weight of the various building components should be minimised, so the structure can be erected without a need for specialist equipment and the components can be moved on the building site by human power. The maximum weight per person on the building site should not exceed 25 kg. Construction of the shelter should be easy, thus allowing non-professional construction workers to erect the buildings quickly.

The aforementioned criteria and aspects will be now incorporated into the proposals for the Transportable Emergency Cardboard House.

§ 7.3 TECH 01 - unbuilt

Author: Jerzy Latka

Year: 2014

Location: Iraq

Area: 17.4m² (size: M)

Lifespan: Temporary (estimated lifespan five years)

Type: Emergency / temporary shelter

The TECH 01 is a lightweight cardboard structure designed to be used as an emergency or temporary shelter for refugees and victims of natural and man-made disasters.

The aim of the project is to create low-cost, easy-to-transport, lightweight and eco-friendly structures that may serve as houses or educational or medical units. TECH

01 will replace the typical tent structures provided to refugee camps by UNHCR. It will provide people with a higher degree of comfort, including privacy, safety and indoor thermal conditions.

§ 7.3.1 The design objectives

The design objective of the TECH 01 is to provide a low-cost house that can be mass produced and delivered to the desired location in a shipping container. The house should be easily assembled by non-professionals, without any need for specialist tools that may not be available at the refugee camps. The structure should consist of several elements that can be delivered in a twenty- or forty-foot shipping container. The elements should be lightweight so the future inhabitants can assemble them themselves, using nothing but manpower. The building process should be sufficiently easy to be carried out by non-professionals, possibly under the supervision of volunteers.

The floor area of the house is approximately 17.5 m², which is the minimum required area for a consisting of five persons. Therefore, the minimum floor area for one person is 3.5 m². However, the house could be designed in two different versions, one being a bit bigger (17.4m²) and the other being a bit smaller (12.7m²). TECH 01 can be erected in any configuration the users need: in the form of single units, row houses or a group of houses (nested). Alternatively, several TECH 01 units can be combined to form a long building used for education or healthcare purposes.

§ 7.3.2 Project concept

TECH 01 is a one-room temporary shelter. It has a rectangular shape, whose outer dimensions are 3,740 by 4,950 millimetres, and whose usable area is 17.4 m² (see Fig. 7.4). The shelter has three openings: one door (1,940x800mm) and two windows (920x920mm). Depending on the layout of the plot, the house may be connected to a sanitary unit by means of a second door in the back wall. The doorway and windows are in the short walls (front and back walls). No openings will be created in the long walls to enable alignment of the houses in a row. The foundations of the shelter may take the form of concrete blocks, made on site by filling the provided paper tubes (with a diameter of 300mm) with concrete on levelled ground, covered with a plastic sheet.

Alternatively, the building may be anchored to the ground by means of ground screws. The height of the house is 1,920mm at the lowest point (the connection between the roof and the walls), and 2,300mm at the highest point (the ridge) (see Fig. 7.4).

The houses may be delivered in a range of colours to help the users identify their own houses.

The project was designed with a particular group of users in mind: Iraqi and Kurdish refugees. The average male in this group is 1.65m tall. [5] Therefore, the various components of the house, such as doors or walls, did not have to be as tall as they would have been in Europe.

The size of the building elements and components is determined by packaging and transportation requirements. The houses were intended to be sent to the site in a shipping container. As mentioned above, two types of containers were taken into account. Ten units of 12.7 m² and six units of 17.4 m² can fit into one forty-foot container (2,300 by 12,000mm). The largest elements of TECH 01 are its roof plates, whose maximum dimensions are 2,270 by 5,900mm. As a result, the plates fit into a forty-foot shipping container. The roof plates for a smaller unit have a maximum length of 5,700mm, which means they can fit into a twenty-foot container (see Fig. 7.3). After unloading, the container can be shipped back or used as a sanitary or kitchen unit or other facility by the aid organisation running the camp.

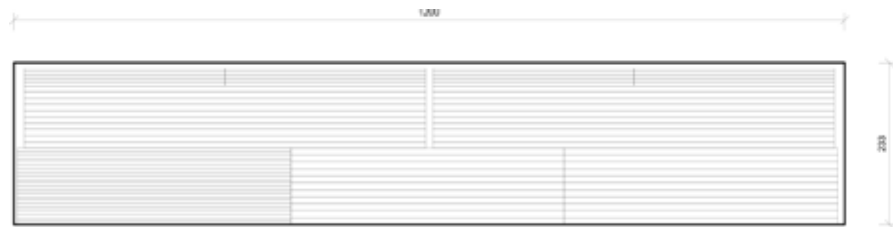

FIGURE 7.3 Arrangement of the TECH 01 11,0 m² components in 40' shipping container

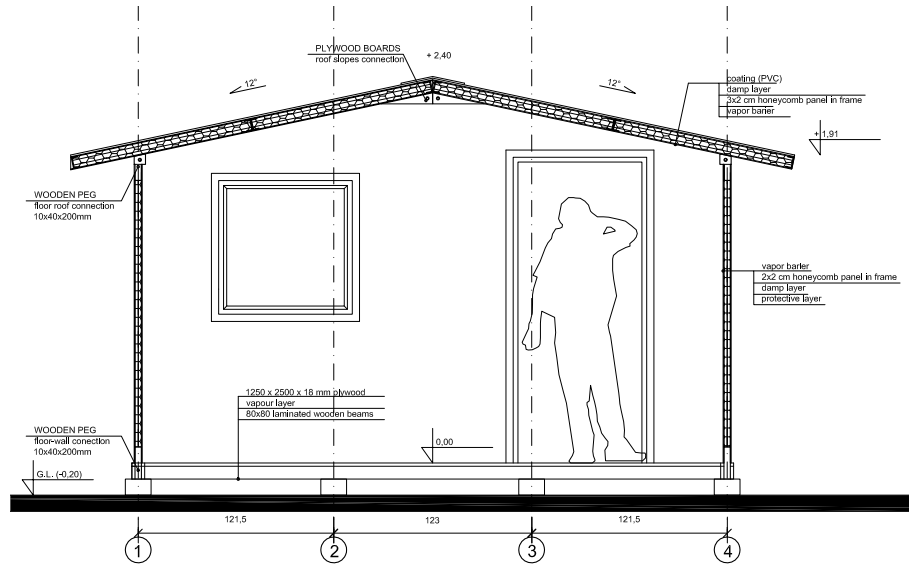

FIGURE 7.4 Tech 01 section

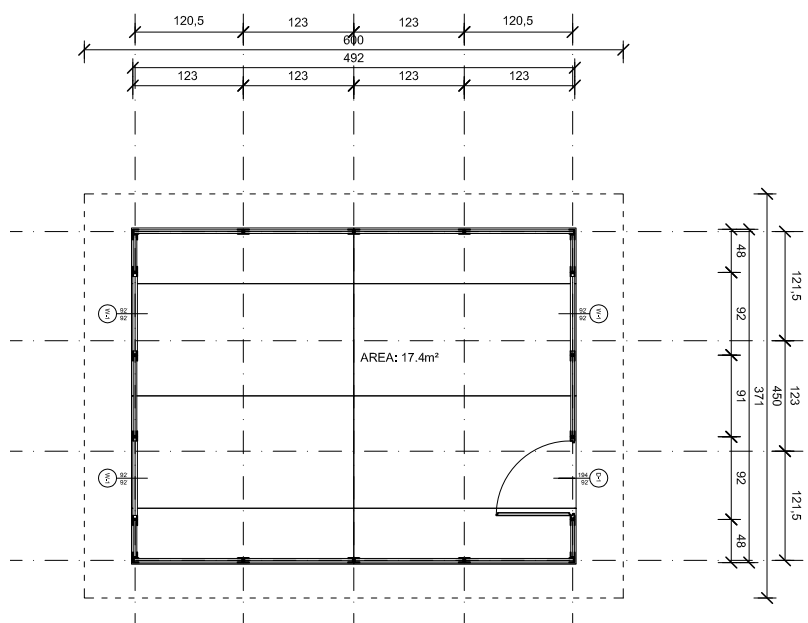

FIGURE 7.5 TECH 01 floor plan

The TECH 01 is designed in several components, which can be arranged in different setup. It is possible to make some variation in the spatial arrangement of the structure. Components in form of wall panels, floor and roof can be prepared in advance in factory and depending on the need, can be picked up like IKEA furniture packed in the boxes and combined together. Floor elements and roof panels stays the same. Therefore, the structure can be built as a single housing units or in a row, to serve as a row houses or as an educational or healthcare units (see Fig. 7.6 and 7.7).



FIGURE 7.6 TECH 01 Housing units



FIGURE 7.7 TECH 01 School

§ 7.3.3 Technical and material solutions

TECH 01 consists of three types of components: floor components, wall components and roof components.

Floor – made of impregnated wooden beams (80x80mm) covered with 18mm thick impregnated OSB or plywood board.

Short walls – composed of impregnated cardboard U-shape frames filled with two cardboard honeycomb panels with a thickness of 20mm each (see Fig. 7.8 and 7.9). Honeycomb cardboard panels are to be ordered from an external factory, and must be made of Kraft liner paper. The walls are covered with a vapour barrier on the inside and with a protective waterproof layer on the outside. Wooden joint elements are integrated in the wall panels which can be directly connect to the floor and roof components. The short walls are composed of five panels. One of them includes door and three panels include windows. Each wall is delivered as one integrated component.

Door D-1 – a pinewood frame with a lightweight wing. The wing of the door is composed of two plywood boards filled with a 20mm honeycomb cardboard panel. All doors come with handle hinges and a lock. The doors come in different colours.

Window W-1 – pinewood frame window, filled with 2mm Plexiglas, single glazing. The window comes with a handle and hinges.

The doors and windows are to be ordered from an external factory ready to be installed in the walls.

Long walls – composed of impregnated cardboard U-shape frames filled with two cardboard honeycomb panels with a thickness of 20mm each. The honeycomb cardboard panels are to be ordered from an external factory, and must be made of Kraft liner paper. The walls are covered with a vapour barrier on the inside and with a protective waterproof layer on the outside. Wooden joint elements are integrated into the wall panels so that they can be connected to the floor and roof. The two long walls of each unit are composed of four panels measuring 120cm each.

Roof – composed of two panels put together on the building site and placed onto the previously erected walls. Each panel is built out of three layers of cardboard honeycomb panels in a cardboard U-shape frame. The roof panels are covered with a vapour barrier on the inside and with a protective waterproof layer on the outside. Wooden joint elements are integrated into the roof panels. They are used to connect

the panels to each other and to the walls. The roof pitch is twelve degrees, and its eaves are 40cm on the long side walls and 42cm on the short side walls.

Ventilation is provided by ventilation opening in the gable walls just under the connection between the two roof panels on either side of the house.



FIGURE 7.8 TECH 01 - wall component prototype



FIGURE 7.9 TECH 01 - wall component prototype front view

TECH 01 was designed to be an easy- to-transport, lightweight and easily erected emergency shelter. Composed of simple components, it can be erected by the future inhabitants (i.e., non-professional construction workers) with the help of volunteers. This method, which is called a self-help or mutual-aid programme, was successfully used by organisations such as Habitat for Humanity, Voluntary Architects Network or government programmes in Puerto Rico in the 1950s and 1960s. [6] Obviously, this method only works if the design of the structure is clear and easy to understand. Furthermore, each component must be lightweight so that the whole structure can be erected without any heavy equipment.

Once the components have been unloaded from the shipping container, the first thing to do is to prepare the ground. Once the ground is level, the following steps must be taken (see Fig. 7.10):

- Foundation – several methods are available to lay foundations, depending on the type and hardness of the local soil. If the soil is hard, levelling is required. Then plastic foil is placed on the ground, with the floor components on top of it. The floor components are connected to each other by means of bolts or screws. If the soil is softer, ground screws can be used to level the ground and to increase the distance between the ground and the floor, which will stop water from damaging the floor components and will enable the installation of an UFAD (under-floor air distribution) system. Alternatively, holes can be dug into the ground and filled with paper tubes with a diameter of 20cm and filled with gravel and concrete. The floor components will then be installed on the resulting paper-tube pillars.
- Once the foundation and floor have been set, the wall panels can be plugged in. As the first prototype shows, each wall panel has two wooden pegs that fit into the holes in the floor components. Subsequently the wall panels are screwed to the floor components and connected to each other by means of bolts.
- Next the roof components must be installed with the use of a ladder.
- Once the assembly process has been completed, the bolts and screws should be screwed into place and the connections between the wall components, walls and floors must be covered with adhesive tape to protect them from leakage (see Fig. 7.11).

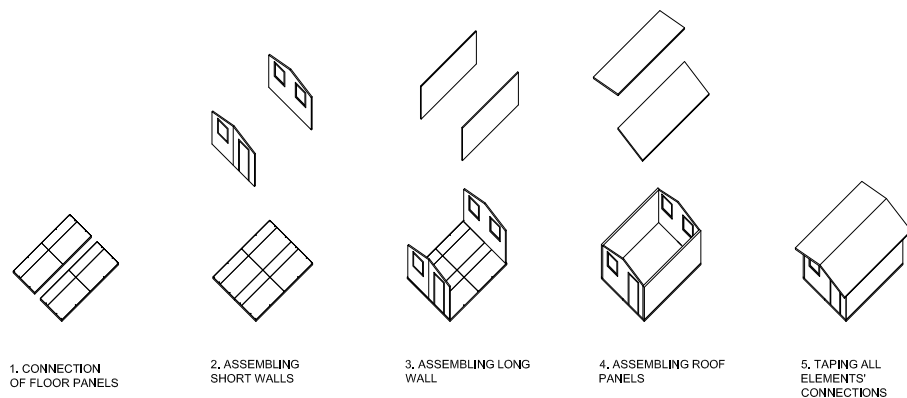

FIGURE 7.10 Assembling scheme of TECH 01

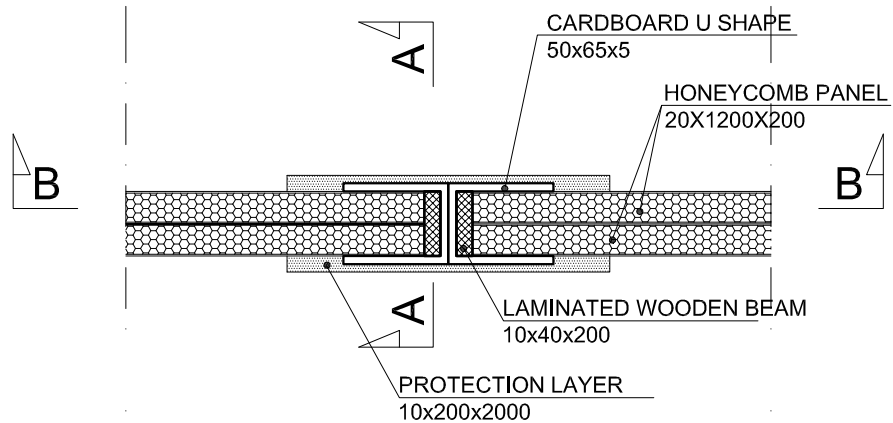

FIGURE 7.11 TECH 01 detail of the wall panels connection

TECH 01 is a prefabricated house whose components are prepared off site. Elements such as honeycomb panels, U-shaped cardboard profiles, plywood, OSB boards, windows, doors and beams will all arrive at the factory in the desired dimensions. The elements are then impregnated – i.e., covered with a protective layer – and painted if desired. Later they are dried at the factory’s carpentry shop and drying plant. Once the drying process has been completed, the elements are delivered to the main hall of the factory, where they are assembled in three separate assembly lines: a roof panel line, a floor line and a wall line.

Once the components have been assembled and undergone quality and dimension control, they are packaged and several packs are transported together in a twenty- or forty-foot shipping container. Each TECH 01 flatpack (containing a 17.4m² unit) will measure 580 by 230 by 75cm.

After arriving at the desired destination, the components are unloaded from the container and prepared for the erection of the house.

§ 7.3.4 Evaluation

TECH 01 is a project of temporary and emergency shelter which was designed to replace the typical UNHRC family tents. The possible rearrangement of the shelter layout gives broader opportunities to use the structure not only as a housing unit.

The shelter consist of several components which can be stored and transported by means of shipping containers. The wall and roof panels are composed of U-shapes frame filled with honeycomb panels. The timber joints are integrated into the panels. Such a solution allow the builders for acceleration of construction works. The prototype of the wall panel was built in order to check the feasibility. The connection between the floor and wall panels need to be further elaborated. As the project was finalized in the concept phase the impregnation was not taken into account. The production, transportation and building processes were thought through. In case of serial production the concurrent manufacturing, where several components are produced in the same time can be adapted. The project was a proposition for the northern Iraq, where many refugees stay in the camps and the housing conditions are poor.

§ 7.4 TECH 02

Authors: Alios Knol, Dion Lachman, Iris van der Weijde, Marijn Verlinde, Wouter Kamphuis, Erik van den Broek, Max van den Berg, Maarten van den Kuur, Roman Oost, Merijn de Leur, Eline Stubert, Jochem Chauoat, Arko van Ekeren

Tutors: Jerzy Latka, dr Marcel Bilow

Year: 2015

Location: Iraq

Area: 13m² (size M)

Lifespan: Temporary (estimated lifespan five years)

Type: Emergency / temporary shelter

After the evaluation of the TECH 01 project and analysis of the technical solution the design objectives for the next version of Transportable Emergency Cardboard House were set. The TECH 02 was designed and build by group of students supervised by author of this thesis and dr Marcel Bilow. The various aspects of the project were elaborated in sub-groups. The project was realized during the Bucky Lab course at

Faculty of Architecture TU Delft in summer semester 2014/2015. At the end of the course, the prototype in 1:1 scale was built.

§ 7.4.1 Design objectives

On the basis of the previous project of TECH 01 the structural system was chosen as a beam-and-column rod structure. The frame structure was decided to be made out of U- or L-shapes, and the wall and roof panels out of corrugated cardboard or cardboard honeycomb panels.

The size of the shelter should not exceed 17.5 m² and it should be composed of building elements and components which can be pre-fabricated and delivered to the building site. The size of the shelter should allow the builders to be constructed without using any special equipment.

The destination area of the project was the north Iraq and Kurdistan.

§ 7.4.2 Project concept

TECH 02 is a single-space unit with a usable area of 12.96m². It consists of prefabricated components that are shipped to the site and assembled by the future inhabitants of the unit. Since the structures are to be erected by non-professional construction workers, their design must be basic and readily understood by regular people. Depending on the inhabitants' needs, the wall panels can be equipped with a fixed door or window. The units can be clustered so as to create a row of houses or bigger buildings, such as school buildings. The initial design assumed a nested arrangement, in which four units were put together, with a common space in between. A common sanitary, heating and cooking unit could be installed in that shared space.

Three different layouts were proposed for TECH 02, each linking private houses with semi-public and public areas in a different manner. The layouts formed easy-to-build patterns that organised:

- Roads and public spaces
- Shared community spaces, semi-private spaces and entrances

- Optimal orientation vis-à-vis the sun for passive energy gains

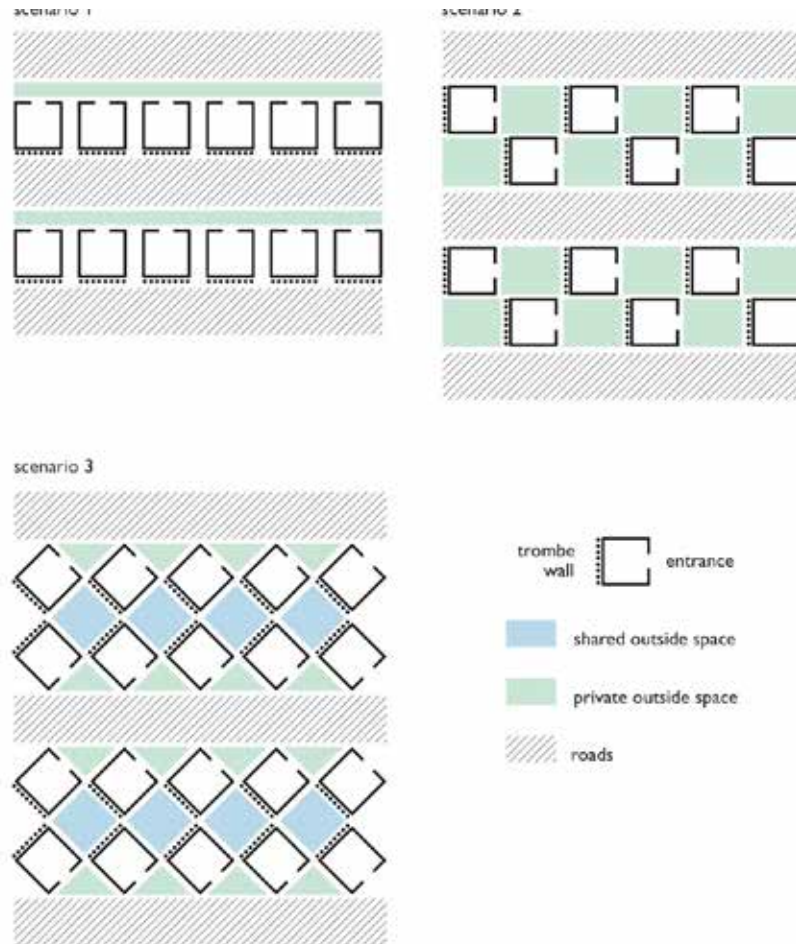

FIGURE 7.12 Spatial arrangement of TECH 02

The structural system used in TECH 02 is a rod system. Beams and columns are the most important load-bearing elements. The building consists of prefabricated components of modest dimensions, so that the whole structure can be erected by manpower, without any need for heavy equipment. Since the wall panels all have the same dimensions, the layout of the house can be rearranged. Elements such as

windows, doors and Trombe walls can be installed in accordance with the directions of the sun.

Since the house is made of rigid materials and has solid floor panels, walls and roof elements, the inhabitants will experience a sense of security, privacy and homeliness. The wall panels are made of cardboard elements, so their outer layer can be printed to allow the inhabitants some form of customisation. The printable surface of the walls can also be used for advertising for the companies supporting the project.

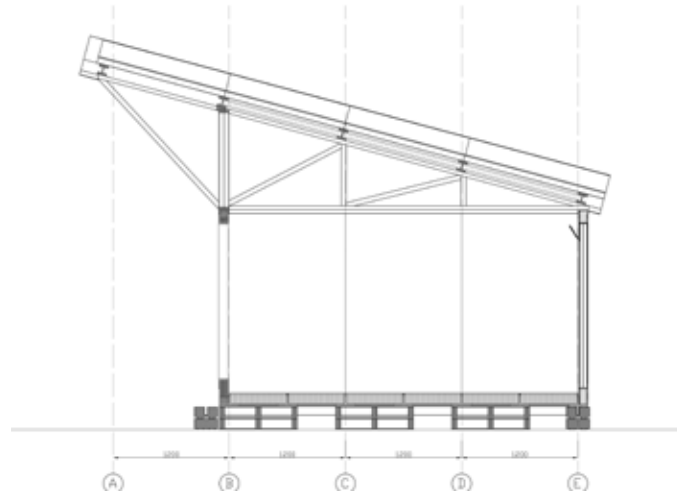

FIGURE 7.13 TECH O2 floor section

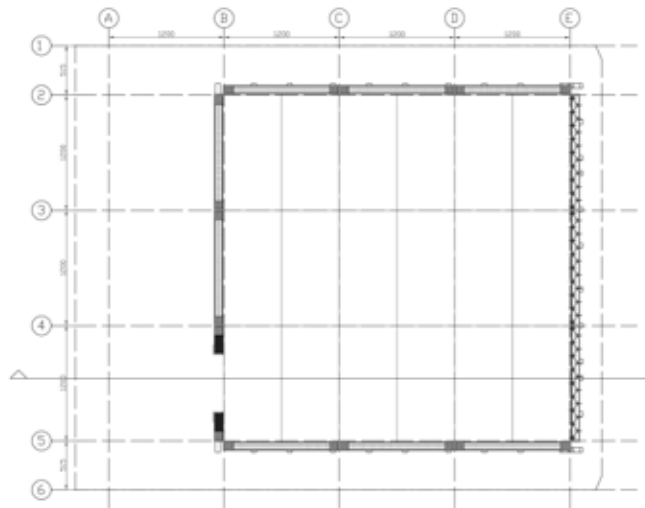

FIGURE 7.14 TECH 02 floor plan

As the proposed location for the camp was northern Iraq, the climate was obviously a major factor that had to be taken into account in the design of the unit. Research indicated that Iraq has three types of climatic conditions: arid/desert, semi-arid/steppe and Mediterranean. Only the latter two types of climate can be found in northern Iraq. A Mediterranean climate is characterised by warm-to-hot and dry summers and mild-to-cool wet winters. A semi-arid/steppe climate is characterised by hot or even extremely hot summers and mild or warm winters. Two cities in the north of Iraq were taken into account as representative locations for the climate assumptions: Mosul and Sulaymaniyah. Mosul can be extremely hot during the summer, and temperatures can rise to 48 °C and drop to -11 °C during the winter. Therefore, this city was chosen as a potential location. Other circumstances to be considered were rain and snow, which appear during the year. The sun path in Iraq was examined in order to help design the roof. The angle of the sun is 28° on the 21st of December, and 73° on the 21st of June.

§ 7.4.3 Technical and material solutions

Foundations and floor.

Several types of foundations were considered. Deep foundations such as piles, piers, caissons were found to be undesirable because they require intensive preparation, e.g. deep excavations. Shallow foundations, sub-divided into spread footing/open trench foundation, pad foundation, strip foundation, grillage foundation, raft foundation and inverted arch foundation, seemed to be more suitable for the construction of emergency houses.

Northern Iraq has mountainous terrain: the Zagros mountains. Therefore, the foundations used for TECH 02 had to compensate for unlevelled terrain. The soil in the area is rather rocky. Because of the brown soil and rough mountain scenery in this region, digging the land is hard.

The following objectives were assumed for the foundation and the floor:

- Due to the enormous temperature differences (-11 °C in winter to 48°C in summer), the floor should be well insulated
- Airflow under the floor is a beneficial solution for extremely hot seasons
- In the winter airflow under the house is not desirable due to the fact that cold air will negatively affect the insulation of the house
- The structure must be water- and snow-resistant. Since cardboard is used as a construction material, this is an extremely important aspect. The floor should be at least 20cm off the ground, to prevent the risk of flooding
- A watertight layer should be installed between the floor and the foundation
- Nothing should be left in the ground once the unit has been demolished
- Rocky and uneven terrain requires levelling of the ground
- The floor should have high thermal insulation values
- Floor panels must be watertight on both sides: from the outside because of rain and flooding, from the inside because of spilt water
- All components should be able to be carried with ease by two persons
- The structure should be kept in the place despite of wind loads by means of foundations and other possible solutions:
 - Weights on the ground (sandbags, cardboard boxes filled with stones)
 - Anchored to the ground by canvas, cables or wires
 - In-soil foundations: poured concrete, drilled or hammered piles into the ground
- The foundations and floor should form a well-functioning system with the walls.

The foundation blocks were made out of EURO pallets used for transport. The size of each foundation block was 200x800mm, which means that they were cut from standard-size EURO pallets measuring 800x1,200mm. The pallets were put on the ground, which had been prepared and levelled (where necessary) beforehand, and stacked in pairs on top of each other (see Fig. 2.15). The space between the planks of the foundation blocks was used for UFAD (under-floor air distribution) and for bags filled with sand or stones, which added some weight to the structure.

The floor consists of two parts: beams and floor panels. The beams were composed of two L-shape profiles of full cardboard, measuring 100x100mm, with walls 10mm thick (see Fig. 7.16). These were glued together in the form of a T-shaped beam or cross-shape beam. The cross-shape beams were placed at the edges of the foundation and were used to connect the floor structure to the walls. The T-shaped beams were placed downwards when placed on the foundation blocks, so the beams were able to fit into the slot between the planks of the foundation block. On top of this structure, T-shaped beams were placed upwards in the opposite direction. All the beams were connected to the foundation blocks by means of screws. The upturned T-shapes of the second layer of the floor beams created a grid which was filled with floor panels.

The floor panels were composed of two OSB layers measuring 1,200x600x18mm on the top and the bottom and five layers of honeycomb panels measuring 1,200x580x20mm. The elements were glued together. The two OSB layers helped to achieve a waterproof layer and reinforced the panels.

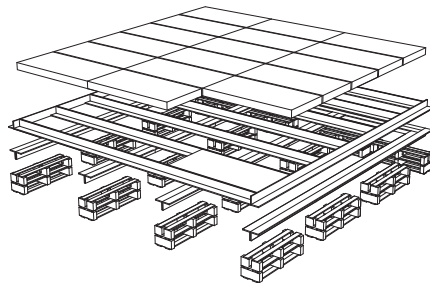

FIGURE 7.15 Exploded axonometric view of foundation and floor structure

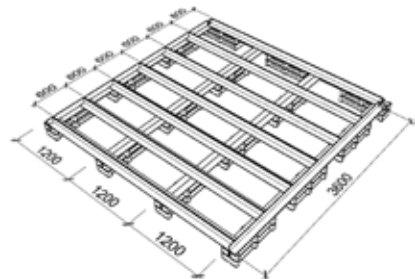

FIGURE 7.16 Axonometric view of foundation and floor structure

Walls

In the early stages of the process the initial ideas of the wall structures were considered and combined into a matrix in which all the pros and cons of the different properties were assessed.

Since the stability of the shelter depended on its wall system, certain design objectives for the wall structure had to be assumed:

- Due to the need for thermal insulation and the fact that the walls would be load-bearing, two types of the wall should be considered:
 - Filled load-bearing wall (or cavity wall), filled with local materials
 - Lightweight sandwich panel wall with secondary load-bearing frame structure
- Transportation issues refer to the size and weight of the building components. To ensure hassle-free transportation, all the elements should be able to fit into a twenty-foot shipping container and onto a standard EURO pallet. These requirements resulted in a maximum cargo height of 2.20m and a maximum cargo width of 1.20m.
- For local people to be able to assemble the housing units without any problems and with little manpower, the units had to be lightweight and consist of very basic components. The maximum weight lifted by one was estimated to be 30 kg. Therefore, the maximum weight of one single wall component should not exceed 60 kg, to allow it to be lifted by two persons.
- The structure should be designed in such a way as to allow non-professional construction workers to erect it quickly and easily. By implementing smart design solutions, the designers could guarantee that no heavy equipment would be needed to erect the structures.
- The relationship between inside and outside, i.e., the positioning of the door and windows, should be flexible and able to be changed depending on the layout of the site and the cardinal directions.
- The wall panels should have good thermal insulation values in order to provide a comfortable living space in extreme conditions, with temperatures ranging from -11°C to 48°C .
- A passive-energy system like a Trombe wall should be affixed to the wall panels that are exposed to sunlight coming from the south-east or south-west.
- The wall structure should be properly impregnated against water, fire, moulds and insects. At the very least, the frame structure should be carefully impregnated against water, and the wall panels should be easy to replace in case they get damaged by weather conditions.

The walls were divided into two elements: a load-bearing frame structure and wall panels.

The frame was composed out of L-shapes measuring 100x100x10mm and 2,000mm long which served as columns. There were two different types of columns: corner and middle ones (see Figs. 7.17 and 7.18). The four corner columns consisted of three L-shapes laminated together to form a cross-in-section profile. The middle columns were composed of two L-shapes glued together to form a T-shaped column. There were eight middle columns, i.e., two for each wall.



FIGURE 7.17 Corner column



FIGURE 7.18 Middle column

Wall panels

As far as construction was concerned, there were two different types of wall panels: regular wall panels and special Trombe wall panels. All the panels measured 120x200cm, regardless of their type. This allowed the creation of a modular wall system and allowed the wall panels to be installed in different positions, depending on the climatic conditions and cardinal directions.

The regular wall panels measured 120 by 200cm and were between 85.6 and 92mm thick. The regular wall panels were composed of several corrugated boards and honeycomb panels laminated together. A wooden block measuring 9 by 9cm was attached to each corner of the panel (see Fig. 7.19). Then the whole panel was covered on both sides with additional layers of corrugated board. The wooden blocks were used for fixing the panels to the load-bearing frame construction built out of T- and X-shaped columns. The edges of the panels were sealed by strong duct tape. The panels were 9cm thick. As a result, the wall panels beautifully fitted into the frame structure.

Three different options for the composition of the regular wall panels were designed and prepared in order to test their properties and mechanical behaviour in a final prototype structure. The options ranged from a combination of honeycomb and corrugated board to completely corrugated plates (see Fig. 7.20).

Option one consisted of three 20mm thick honeycomb panels alternating with two five-layered corrugated boards that were 6.4mm thick. Additional corrugated plates were attached on both sides to keep the wooden blocks in position and to protect the honeycomb panels. This panel was 85.6mm thick.

Option two consisted of two 30mm thick honeycomb plates alternating with three plates of five-layered corrugated boards with a thickness of 6.4mm. Additional corrugated boards were glued to the outer surface of the panels in order to hide the wooden blocks and keep them in position. This panel was 92mm thick.

Option three consisted entirely of corrugated boards. As corrugated board has the best mechanical properties in the longitudinal direction of the corrugation, the boards were laminated in two perpendicular directions so as to make them stronger and more rigid and so better able to withstand vertical and lateral forces. Additional corrugated board plates were attached to cover the wooden blocks. The thickness of panel no. 3 was 89.6mm. It was composed of fourteen five-layered corrugated boards, each 6.4mm thick.

Out of the three aforementioned options, option no. 1 was the best solution, because it was lightweight and had good thermal insulation properties. Option no. 3 was far too heavy and option no. 2 had lower thermal insulation values due to the smaller number of air cells in the individual boards.



FIGURE 7.19 Wall panel

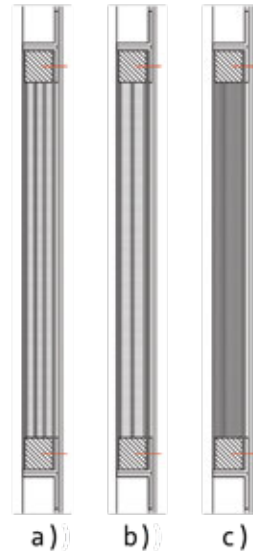

FIGURE 7.20 Wall panels, a) option one, b) option two, c) option three

Furthermore, special panels incorporating doorways and window frames were prepared. These panels were composed of layers of honeycomb and corrugated board, combined in the same manner as the regular wall panels. The doorways and window openings were covered with L-shapes in order to get a protected frame ready for the installation of a door or window. The window was incorporated into the panel during the prefabrication process. The doors are to be installed on the site.

Cardboard in its solid form has high thermal insulation properties. According to CES EduPack's website, soft cardboard has a thermal conductivity of 0.12 W/mK , which is almost three times better than common wood materials like plywood or OSB, whose thermal conductivity is 0.35 W/mK . However, these properties are changed significantly when cardboard is used in the form of corrugated boards and honeycomb panels, whose small cells contain trapped air. Air has a conductivity value as low as 0.02 W/Km , so if air is trapped inside the cardboard elements and the cells are small enough that the air is not moving, the thermal insulation value of such material increases. A wall element consisting of two layers of honeycomb alternating with corrugated plates was modelled in the TRISCO software package. A simulation was carried out at an established outdoor temperature of -10°C and an internal heat load of five persons, as each unit is designed for one family consisting of five members. The results showed that this situation would be enough to maintain an indoor temperature of 18°C .

In order to achieve passive energy gains, one of the walls was designed to be a cavity wall making up a Trombe wall system.

Trombe wall systems use thermal mass and cavities between the mass and the transparent material to provide passive ventilation, heating and cooling. This system was proposed in order to temper Iraq's frequently very high temperatures (see Fig. 7.21).

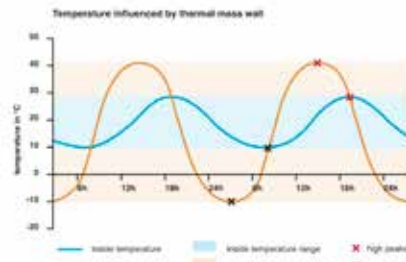

FIGURE 7.21 Temperature influenced by thermal mass wall

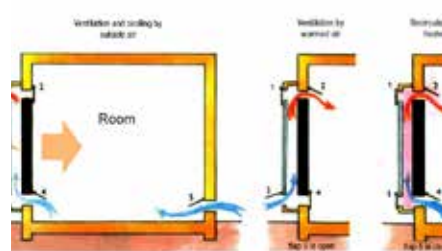

FIGURE 7.22 Trombe's wall principle diagram, source [8]

The principle behind Trombe walls is centred around the thermal mass and cavities between the mass and the transparent material which is applied to the outside of the wall. Thermal mass, usually painted dark, soaks up heat during the day. In the evening it will radiate the heat it has collected during the day into the room. In addition, Trombe walls can be used for cooling and ventilation purposes. Trombe walls can be used in three different situations, which will be outlined below (see Fig. 7.22).

In the first situation, heated thermal mass is used to create underpressure between the thermal mass and the transparent layers. This will cause the air to be sucked out and leave through a gap at the top of the wall. Fresher and cooler air is sucked in from the gap under the door. In such cases, where the inside temperature is higher than the outside temperature, the system works as a cooling system.

In the second situation, air that enters the cavity from outside through a gap at the bottom of a wall is heated up by the thermal mass in the Trombe wall before getting

into the room. This solution can be used when the outside temperature is lower than the inside temperature and the room needs to be heated.

In the third situation, inside air is circulated back into the room through the Trombe wall. The air does not leave the unit; it circulates inside the room and the loss of heat is prevented.

The best orientation for a Trombe wall is south, south-west or possibly south-east. As can be seen in the layout of the TECH O2 units, the Trombe wall (marked by dots) always faces the desired direction.

The basic idea behind the Trombe wall was incorporated into the cardboard structure. The wall should contain a filling material and should transfer the forces to the foundations. Air should be guided to the cavity, which has to be covered by a transparent material in order to allow the thermal mass to be heated. The system should enable one to control the air flow between the interior and exterior.

TECH O2's Trombe wall panels measure 1,200x2,000x 110mm. Each panel consists of a bottom and top chamber with openings to both the interior and the exterior of the house, and a part in the middle with air cavities and filling cavities (see Fig. 7.23). The bottom and top chambers are composed of L-shape profiles laminated together in the form of Z-shape profiles. Wooden blocks measuring 90x90mm are attached at both ends of the rows of Z-shape profiles in order to mount the Trombe wall panel in the same manner as the other panels. The air cavity and filling cavity are made of laminated L-shapes in the form of a zigzag pattern that divides the wall panel into two parts. One side can be filled; the other is left open to serve as an air duct. Eight triangular cavities have a filling volume of 0.034m^3 . The triangular division on the outside is painted black and closed off with Plexiglass. Inside the wall, the filling cavity is covered with plywood. Three types of fillers were considered for the project: sand, which weighs $1,400\text{ kg}/\text{m}^3$ (0.034m^3 results in 48 kg), pebbles weighing $1,000\text{ kg}/\text{m}^3$ (0.034m^3 results in 34 kg) and sheep's wool, the lightest material, weighing $22\text{kg}/\text{m}^3$ (0.034m^3 results in 0.8 kg). All the above materials were considered as local and dry materials that might be used as a filler. While sheep's wool has very high thermal insulation properties, it also has low mass. For this reason, it is not advisable to use sheep's wool as a thermal mass filler.

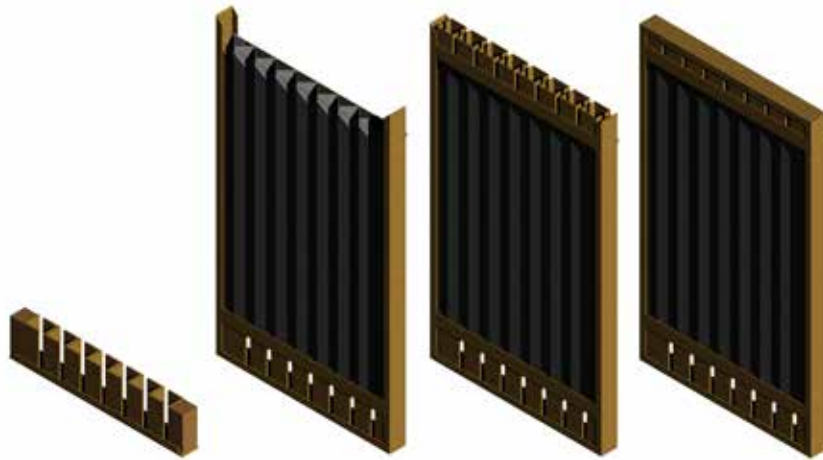

FIGURE 7.23 Trobme's wall panel

Roof.

Research into different types of roofs was conducted at the beginning. Nine different roof structures were considered: dome, chapel roof, textile roof, double-curved roof, tropical roof, flat roof, pent roof, folding roof and cable roof.

At the next stage, design objectives were carried out:

- The roof is mainly made of cardboard
- Roof components must fit into a shipping container
- The roof components must be small enough to allow people to place the roof over the wall structure using just manpower and regular tools (i.e., no heavy equipment).
- The design of the structure must be easy enough to allow non-professional construction workers to erect the structure
- The roof must come with thermal insulation material
- The form of the roof must allow for passive cooling, which means a tropical roof solution is desirable
- The roof must have at least a 15-percent slope in order to allow snow and rain to slide off. A sloping roof may provide the house with additional lighting
- The eaves must overhang, thus protecting the walls from rain and creating a semi-dry space for outdoor activities
- The roof structure must be rainproof

- The roof structure must be demountable in the event that one of its components gets damaged and must be replaced.

It was decided that the unit would have a single pitched tropical roof. In a tropical roof the layer of air between the top of the roof and the interior of the shelter is heated. The heated air inside the roof will start to flow upwards and so ventilate away heat which otherwise would have entered the shelter. This solution is desirable during the day, when the heat of the sun can raise the temperature in the shelter. At night, the air between the various roof layers should be preserved in order to provide additional thermal insulation. For this reason the tropical roof should be closed at the end of the day so as to create an air pocket (see Fig. 7.24).

In addition to using a tropical roof, the group considered the Venturi effect. This effect is caused by the accelerating velocity of the air stuck inside the roof. Decreasing the cross-section of the air flow will result in accelerated flow, which in turn results in additional ventilation, due to pressure differences.

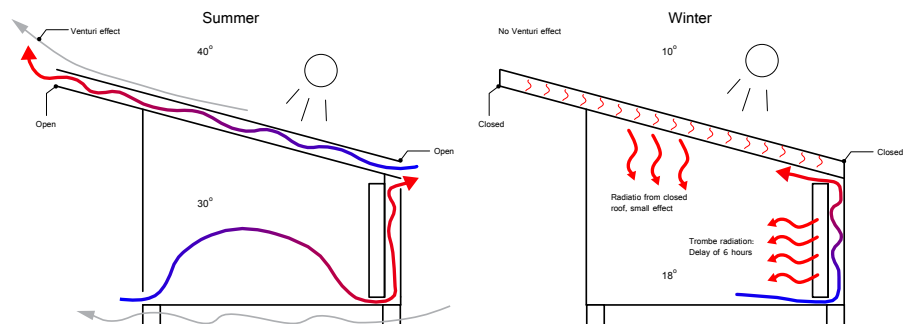

FIGURE 7.24 Tropical roof, venturi effect and Trombe's wall scheme

In order to create a tropical roof with a Venturi effect, the team had to come up with a special roof structure. This roof consists of four elements:

- A truss, which provides the slope and cantilever that will create a semi-dry and semi-covered outdoor space where daily activities can be carried out. The truss structure is composed of cardboard U-profiles connected to wooden planks. As a result, it is a lightweight and stable structure. Two trusses are attached to the tops of the side walls.

The trusses are covered on the outside with Plexiglass, which will allow natural light to enter the house. Between the trusses, at the front of the house, there is a window frame over the entrance. This window frame stabilises the trusses in the other direction.

- Five H-beams composed of laminated U-profiles and 9mm wooden laths are attached to the tops of the trusses. The H-profile beams carry the actual roof plates and honeycomb panels between the beams for additional thermal insulation. The span of the beams is 4.6m. They cover
- The roof plates at the tops of the beams are made of corrugated board folded into triangular tubes. The tubes create channels which is to say they allow the air to flow inside the roof structure. The triangular tubes can be used as a thermal insulation method during the cold season by closing the flaps at the ends of the channels. To create the channels, corrugated plates are hooked into each other and are folded in the form of triangular tubes. The direction of the corrugation determines the strength properties of the roof plates. If the corrugation travels sideways, the triangles will be more dimensionally stable. If the corrugation travels lengthwise, the cardboard will be stronger, and it will bend rather than tear. The results of the material tests described in Chapter 2 showed that the orientation of the triangles makes a significant difference. Triangles pointing up will bend, whereas triangles pointing down will break. The bottom plate with the triangles pointing up is folded along the corrugation line in order to assimilate the tension. The upper layer of the roof plates with triangles pointing down is folded perpendicularly to the corrugation to assimilate the tension and make the plate stable.
- The final layer of the roof is a protective layer made of corrugated cardboard covered with waterproof and fire-retardant foil. This protective layer is wrapped around the beams and is connected with the truss. An L-shaped beam is installed under the roof beams, where it serves as a sill.

The trusses are connected to the walls with U-profiles attached to the bottom of the truss and to the tops of the walls. The U-profiles are screwed to the wooden connector of the truss and the wooden blocks of the wall panels.

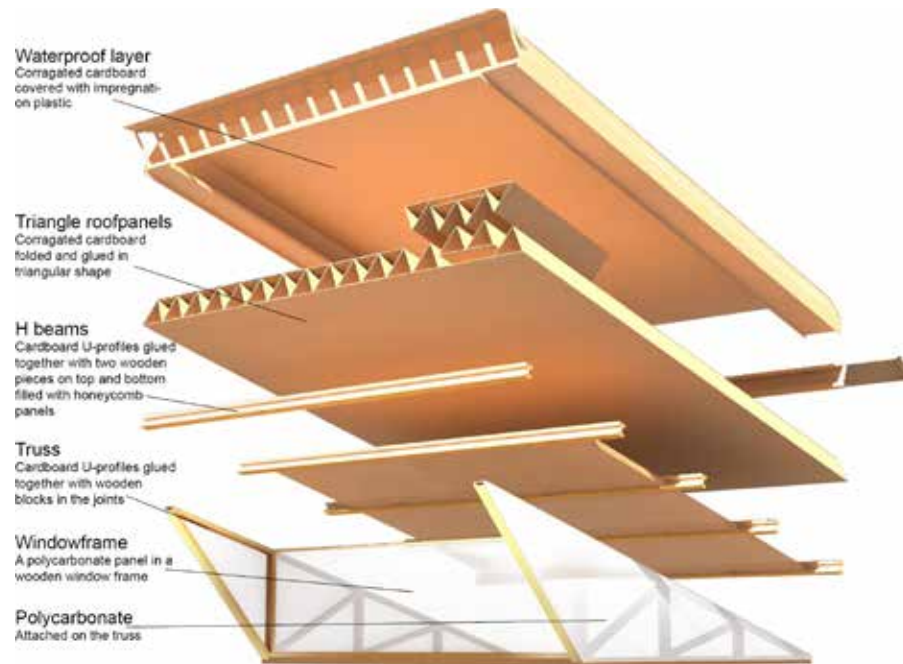

FIGURE 7.25 Roof structure

§ 7.4.4 Prototyping

The building process started with foundations (see Fig. 2.26). Next the corner X-shaped columns were screwed to the wooden foundation through the wooden corner blocks. The first wall panel was connected with an X-column by means of screws. Then a T-shaped column was attached to the panel and the foundation (see Fig. 7.27). The next wall elements were mounted in the same manner until one entire wall was standing upright. Three wall panels and two intermediate T-shape columns created one wall slab. Once all twelve panels had been attached to the foundation, the base for the roof (i.e., U-shaped beams with a 110mm outer width) was placed on top of the walls and screwed to the wooden corner blocks in the wall panels (see Fig. 2.29). Since the wall panels all have the same size, i.e., 1,200x2,000mm, they could be used interchangeably, thus different configurations of the regular and special panels was allowed, depending on the situation on the site (see Fig. 2.28).



FIGURE 7.26 Foundation and floor



FIGURE 7.27 Cardboard T-beam



FIGURE 7.28 Wall panel



FIGURE 7.29 Construction of the roof

The building process of the wall started with the corner X-shaped columns. The columns were screwed to the wooden foundation through the wooden corner blocks. Next the first wall panel was connected with an X-column by means of screws. Then a T-shaped column was attached to the panel and the foundation. The next wall elements were mounted in the same manner until one entire wall was standing upright. Three wall panels and two intermediate T-shape columns created one wall slab. Once all twelve panels had been attached to the foundation, the base for the roof (i.e., U-shaped beams with a 110mm outer width) was placed on top of the walls and screwed to the wooden corner blocks in the wall panels. Since the wall panels all have the same size, i.e., 1,200x2,000mm, they could be used interchangeably, thus different configurations of the regular and special panels was allowed, depending on the situation on the site.

Impregnation

There are many ways of applying a waterproof coating to cardboard. Cardboard elements can be laminated with plastic film, sprayed with an exterior plastic coating, painted or dipped in lacquer, impregnated with wax coating or being impregnated with method called cascading, which saturates the cardboard with a hot wax substance. It is also possible to impregnate cardboard with biodegradable coating made from the pulp of sugar cane.

The research of different application methods was conducted. Because of the financial and time shortage only the exterior application of the coating was taken into account. Several different products available on the market were tested. The impregnation tests were also conducted during the realization of the Wrocław Exhibition Pavilion, which was composed of wooden arcs and paper tubes. The paper tubes were preliminarily impregnated with several different products and then tested.

For TECHO2 impregnation the products available on Dutch market were tested. After the research and choice of products, impregnation tests were conducted.

- Gummil Premium Liquid Rubber – this water based product can be applied to the surface in form of paste and after drying becomes a rubber. Gummil should be applied with a roller, brush or airless spraying. The big advantage of the product is its total air- and waterproof quality and high flexibility, therefore applied to surface it is not sensitive to movements of substrate or rapid changes of temperature.
- Nr. 1 Wood Protector – is used for waterproofing, water- and dirt-repellent of wood. This product can be used only with untreated wood and can be applied with brush, roller and low pressure spray. It ensures optimal protection against moss, algae fungi and weather conditions as well as UV-protection against decolourisation.
- Hempel Dura Satin Varnish Lacquer – a quick drying, silk gloss urethane alkyd varnish. It has a good resistance to seawater, sunlight and adverse weather conditions. Product can be applied to new and previously varnished wood for interior and exterior.
- Ruwa Jacht Lacquer is a strong transparent yacht varnish which is suitable for all woodwork and topcoat for furniture.

COMPARISON	Gummil Premium Liquid Rubber	Nr. 1 Wood Protector	Hempel Dura Satin Varnish Lacquer	Satin Ruwa Yacht Lacquer
Water-resistance	++	+	++	+++
Price	+	-	-	--
Quantity of material	++	+	-	-
Fire-resistance	+	-	+	+
Insects- or pets-resistance	+	+	++	++
Mould-resistance	+	++	++	++

TABLE 7.2 Comparison of different impregnation products

For the impregnation test some specimens were prepared. The specimens were tested by spraying or dipping them in water for a period of ten minutes. The previous research on impregnation of Exhibition Pavilion of Wroclaw University of Technology brought basic knowledge of the impregnated material behaviour, thus after even short time it was possible to assess the quality of impregnation (see Tab. 7.2).

Test 01.

T-profile was impregnated with Gummil Premium Liquid Rubber and Nr 1 wood protector. The rubber was painted on the profiles and the wood protector was sprayed. The best results were achieved by specimen 01 which was completely painted by Gummil. Specimens 02 and 03 were sprayed with Nr. 1 wood protector and the cut parts were painted with Gummil. Difference between specimen 02 and 03 was that in specimen 03 also the gap between laminated L-profiles was protected with Gummil. Results for specimens 02 and 03 were not satisfactory (see Fig. 7.30).

Test 02.

Six specimens of U-profiles were painted with two different lacquers (Hempel and Ruwa). For each lacquer two specimens were painted and the ends were impregnated with Gummil. One specimen of each lacquer was dipped. The tests showed that Hempel Dura Satin Varnish Lacquer brought the best results. However this product is very expensive (see Figs. 7.31 - 7.33).

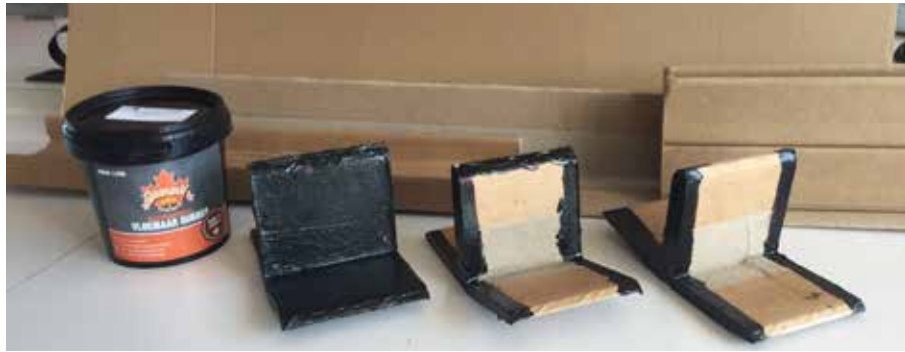

FIGURE 7.30 Impregnation test 01



FIGURE 7.31 Test 02 - impregnated elements



FIGURE 7.32 Test 02 - deeping specimens in water



FIGURE 7.33 Test 02 - results

The foundations consist of parts of EURO pallets and T-shaped beams made of cardboard. As the wood used in the project is not a subject of this dissertation, only the impregnation of the cardboard elements is discussed here. EURO pallets are built out of impregnated timber and can be provided with an additional layer of impregnation by using waterproof paints popular on the market.

The cut ends are the most vulnerable parts of the T-shaped beams. In fact, this is the most fragile part of the entire structure, since water and moisture can get into the material here, dissolve the water-based saccharide glue used for the production of the profile and destroy the bonds between the cellulose fibres in the material through hydrolytic degradation. Therefore, special treatment is needed for these parts of the structure. The edges of the T-shaped beams were impregnated with Gummil Premium Liquid Rubber, while Ruwa Jacht Lacquer was painted on the gaps between the two L-profiles. Due to time and budget constraints, the floor beams covered by the floor panels were left untreated.

The wall structure consists of two different types of elements: a load-bearing frame structure (columns composed of cardboard L-shape elements laminated into T- and X-shaped columns) and wall panels. As water poses a severe threat to structural elements made of cardboard and paper-based products, it is absolutely crucial that these structural elements be impregnated very carefully. A few different impregnation techniques were applied, depending on the element to be impregnated.

Following lamination, L-shaped and X-shaped columns were impregnated with Ruwa Jacht Lacquer. The cut edges of the profiles were additionally impregnated with Gummil.

The wall panels on the exterior side were covered with self-adhesive plastic foil. The foil demonstrated the following properties: water-resistance, smouldering when subjected to fire and transparency. Since the foil was only 60cm wide, several overlapping layers had to be applied. To prevent leakage, the edges of the panels were additionally covered with duct tape. The foil was applied only on the exterior side in order to let the panels breathe, so that if any moisture were to get into the panel, it would not destroy the material but rather evaporate.

In addition, duct tape was used to cover the gaps between the columns and the wall panels.

The truss elements were impregnated with Ruwa Jacht Lacquer after being glued to each other and glued connected with the wooden slats. The roof plates, composed of triangular corrugated plates, were not impregnated at all on this occasion. However, if the shelter were to be produced for a one-to-three-year lifespan, impregnation of all the materials would be required. The covering layer, which consisted of corrugated plates, was wrapped in plastic self-adhesive foil. Furthermore, the connections between the foil layers and the sides of the panel were covered with duct tape.

The TECH 02 prototype was exhibited at the campus of the Faculty of Architecture and Built Environment TU Delft for about a week. Afterwards, the structure was dismantled and the building elements were sent to be recycled (see Figs. 7.34 - 7.39).



FIGURE 7.34 TECH 02 prototype at Faculty of Architecture TU Delft, 2015



FIGURE 7.35 View on the Trombe's wall panel



FIGURE 7.36 Interior of the TECH 02



FIGURE 7.37 Structural elements of TECH 02



FIGURE 7.38 TECH 02, window frame



FIGURE 7.39 Dismantled and ready to be recycled TECH 02

§ 7.4.5 Evaluation

The project of TECH O2 was designed to withstand extreme boundary conditions. In other words, it was a challenge to use all the possible passive energy gains of the proposed design to heat up or cool down the shelter. The chosen site was in the north of Iraq, near the city of Mosul, where temperatures can drop to -11°C in winter and rise all the way to 48°C in summer. The region sees both rain and snow. The soil in that mountainous area is rocky, which makes it hard to dig in it.

TECH O2 was exposed to external weather conditions for six days. Unfortunately, it had to be disassembled after this period.

The foundation elements were made out of Euro pallets, which was low-cost solution. However there were too many elements that had a contact with ground. This could cause the problems in the situation where the ground is not perfectly levelled. It is suggested to develop another foundation system, where only several elements have a direct contact with the ground. The T-shape beams on the floor worked well, but on the other hand in case of water spill inside of the shelter, they might get damaged (see Fig. 7.40). Therefore for floor elements the timber is favoured material. The sandwich floor panels were stable and strong enough to carry the weight of several persons.



FIGURE 7.40 Floor component



FIGURE 7.41 T-shaped pillar

The structural system worked well, the connection between T-shape beams and the wall panels gave sufficient stability, hence no extra stiffen was needed such as diagonal bracing (see Fig. 7.41).

At the corners of the structure, the X-shaped pillars were exposed to the natural condition. This should be revised and another solution, where all the structural elements are hidden from external condition should be developed.

The roof structure should be reconsidered and some alternative solutions should be proposed. TECH 01, the previous version of TECH 02, included a double-pitch roof composed of two plates connected to each other at the ridge. This solution is easier in terms of transportation, erection and usage, but will not provide a tropical roof, nor the Venturi effect.



FIGURE 7.42 Roof structure made out of U-shapes



FIGURE 7.43 Inlets of the tropical roof

The roof is the most significant part of the structure of the house. It makes the interior comfortable and provides shelter from the elements. The roof is the most complicated part of the house, and is also the part of the structure that is most exposed to the elements. Therefore, special attention should be paid to this part of the house.

Some other roof structures that may have potential are outlined below. Further research should focus on the proposed solutions with regard to the material used for the load-bearing structure, impregnation, transportation issues and ease of erection. The proposed type of roof should be treated as a guideline for further research and prototyping.

Different roof types have their own characteristics which can be applied to structures designed for different regions, depending on the local climate.

Flat roofs with a slope between two and ten degrees are predominantly used in hot and dry areas with very little rain. Such roofs are not appropriate for areas with strong winds and hurricanes, as the wind will simply pull off the roof. The material proposed for decking is bituminous roofing felt, especially self-adhesive and modified bitumen types of felt (SBS and APP type) or liquid finishes.

Single pitched, gabled and hipped types of roofs can be used in warm and humid regions with significant precipitation. If the roof slope exceeds thirty degrees, the roof is appropriate for hurricane areas, since flatter roofs (ten to thirty degrees) create suction

forces. Wide overhangs are appropriate for areas with a lot of rain. They cover and protect walls against being soaked by rain. Hipped roofs protect all walls, while gabled roofs only protect the side walls, but they are more difficult in construction. A roofing felt, bitumen, liquid finishes or various plant materials such as thatch or matting can be used as a finishing layer.

Shell structures and bow-string roofs are suitable for earthquake-prone areas. However, they are expensive and hard to produce. Some shells can be prefabricated (e.g. polyurethane igloos) but they seem inappropriate for dwelling purposes.

Other types of roofs are tensile roofs, folded plate roofs and air-supported roofs. Since TECH was designed as a cardboard structure, inflated and tensile roofs do not meet the brief. However, future researchers may wish to focus on a combination of cardboard and textile tensile structures. Folded plate roofs may be a good solution if they are made of cardboard elements, but research on such a solution was not within the scope of this dissertation.

Roof structures and shapes should not only be dictated by local climatic conditions. Like the rest of a structure, the shape of the roof is determined by socio-cultural aspects like religion, family and clan structure, building traditions, attitudes towards the environment, mobility, etc. As TECH is a proposed emergency shelter aimed at inhabitants of different cultural and geographical regions of the world, such aspects should be possible to be changed in specific cases.

A few other examples of possible roof structures involving cardboard elements are listed below. Further research will be required to develop such structures. At this stage of the research they represent different possibilities and forms:

- Double pitched roof
- Double pitched roof with truss
- Flat roof
- Vault roof
- Roof with a reflective surface

§ 7.5 TECH 03

Authors: Jerzy Latka, structural advisor: eng. Julia Schonwalder, technical and production advisor: dr. -ing Marcel Bilow, contractors: Jerzy Latka, Marcel Bilow, Paulina Urbanik, Oglą Gumienna, Joanna Malinska, Agata Mintus, Weronika Lebiedowska, Natalia Olszewska, Magdalena Wiktorska, Damian Wachonski, Wojciech Wisniewski.

Year: 2016

Location: Wrocław, Poland

Area: various (size M)

Lifespan: Temporary (5 years)

Type: Emergency shelter/ Housing

TECH 03 is the final product, based on two previous attempts and research. The prototype of TECH 03 was known as the House of Cards. The House of Cards was awarded the first prize in the FutuWro competition. [9] The project was realised as part of the City of the Future/ Laboratory Wrocław programme, undertaken when Wrocław was a European Capital of Culture in 2016.

§ 7.5.1 Design objectives

The House of Cards was a type of temporary housing designed for asylum seekers, refugees who have fled their homes and homeless people living in Europe. Therefore, the structure had to meet the requirements for (northern) European climatic conditions.

The main idea behind the project was to propose a low-cost, lightweight and easily constructed house for refugees, made of paper-based products. However, the system can be also implemented as an alternative to houses with a medium lifespan, social housing, garden sheds, house extensions, summer houses, temporary offices, showrooms, festival offices, cafeterias, etc.

The structural system employed in the proposal was a column-and-beam system. The frame structure was made out of L-shapes and the wall panels were made out of cardboard honeycomb panels. The house should be easy to build, without any need for special equipment and/or professional construction workers.

The House of Cards is a prototype of a house 70 percent of whose volume consists of paper components.

§ 7.5.2 Project concept

The House of Cards is a temporary house designed for asylum seekers and refugees as well as homeless persons. It was designed to be used in European climatic conditions.

The House of Cards is the third generation of the TECH (Transportable Emergency Cardboard House) projects. Based on previous attempts, several details were improved, including the structure of the roof, the foundations, the wall panels, the connections between the elements, the size and the impregnation methods used.

The structural system used in the House of Cards is called FLe²XARD.

FLe²XARD is an innovative and flexible building concept for houses with a short and medium lifespan (up to twenty years). The system allows users to combine and arrange functional spaces in a flexible manner and offers an affordable, sustainable and adequate accommodation solution.

The basic structural system consists of prefabricated cardboard panels and a cardboard frame structure. The frame provides the structure with added stability and strength. The houses are installed on an elevated floor made of prefabricated slabs levelled by means of ground screws or blocks of concrete. The building process, using prefabricated elements, is fast and easy. The elements do not weigh much, do not take up much storage space and can be easily transported.





FIGURE 7.44 TECH 03 , visualisation

The proposed solution allows different users to choose different types of houses with various functions and various sizes.

There are two basic units, which can be clustered in order to create different configurations (see Figs 7.45 – 7.46).

The smallest units, with a usable area of 12m² or 25m², are designated for singles or couples. A combination of one smaller and two bigger units provides a comfortable space for two big families (ten persons) or eight individuals. A spatial arrangement with an atrium (see Fig7.47) can be used by three families. Alternatively, the buildings can be arranged in a row of houses which can house twelve people (see Fig. 7.48)

-  sanitary unit
-  private area
-  semi private area

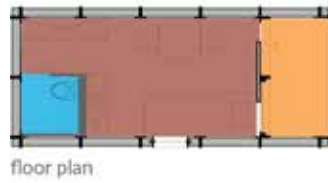

e¹ 

FIGURE 7.45 e¹ unit



e³ 

FIGURE 7.46 e³ unit for one family



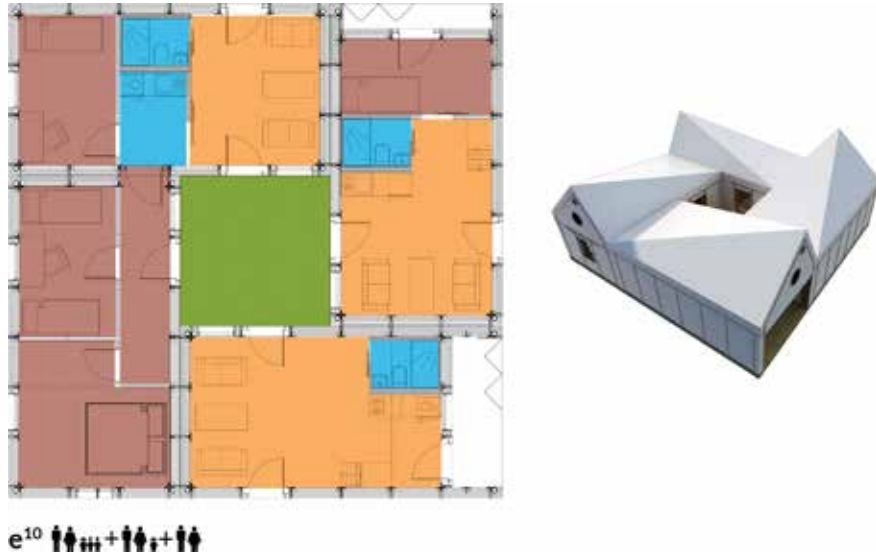

FIGURE 7.47 e¹⁰ for three families

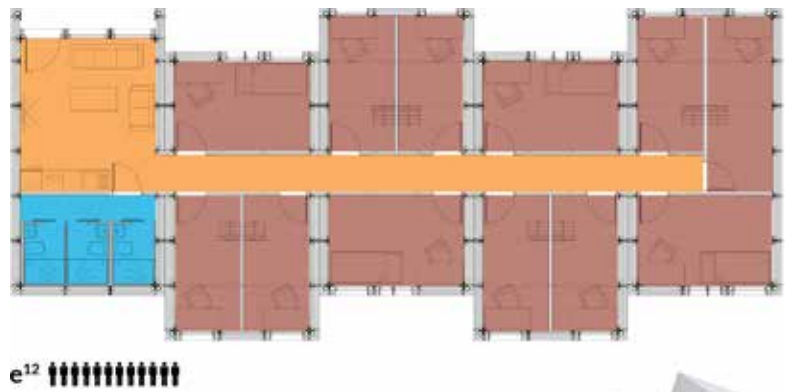

FIGURE 7.48 e¹² for thirteen individuals

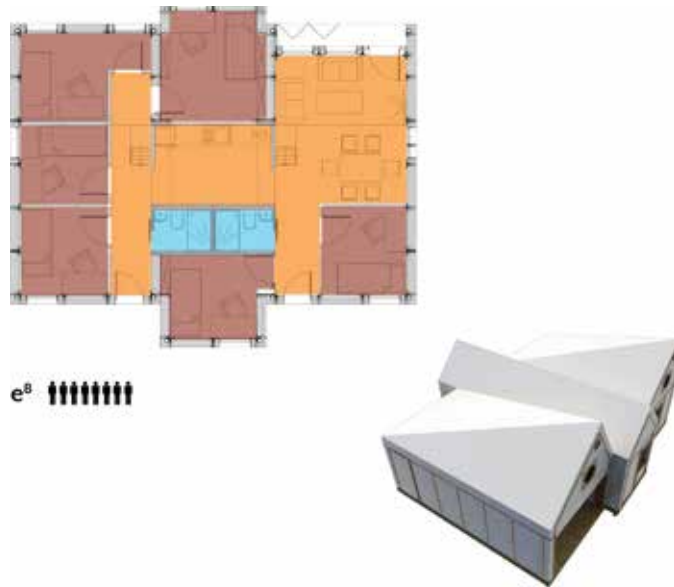

FIGURE 7.49 e^8 for eight individuals



FIGURE 7.50 e^{12} for thirteen individuals

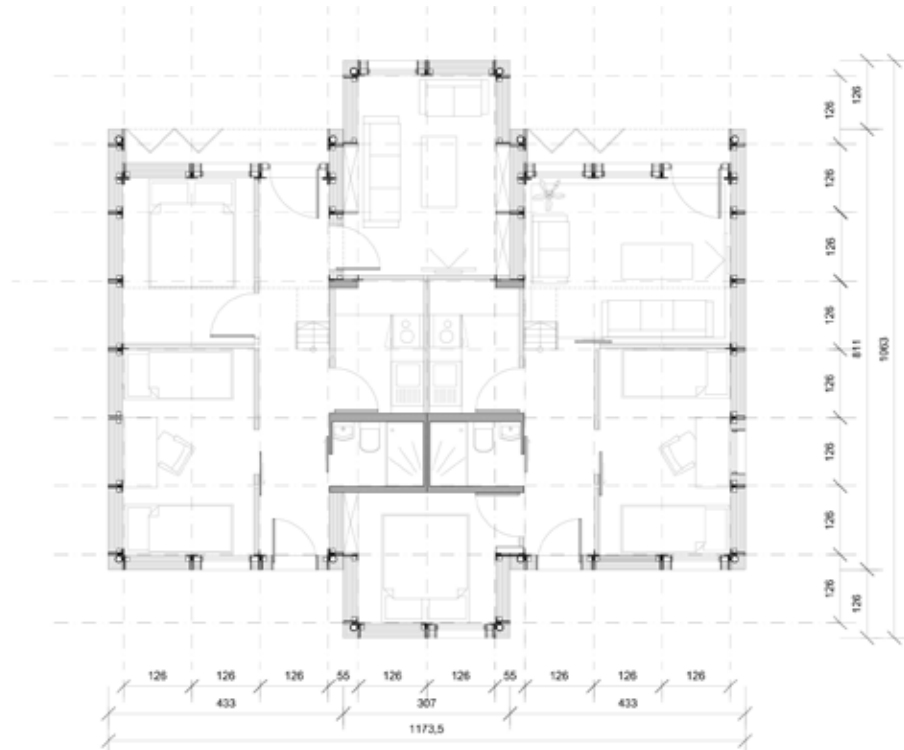

FIGURE 7.51 e¹⁰ for 10 people, 2 families, plan view

The houses look modest, but cover every basic need. The inclined shape of the roof minimises the heatable volume of the house and simultaneously serves as a passive ventilation system. The mezzanine can be used for storage or as an extra bedroom.

The project was kept sustainable by using cardboard as the main building material. Cardboard is recyclable and low cost, especially when it is mass produced. Cardboard has been proved to be a suitable building material in many projects – not just projects involving temporary housing, but projects involving structures for permanent use. The wall panels of the FLe2XARD system are composed of honeycomb cardboard panels covered with water and moisture barriers: polyethylene film on the inside and PVC foil on the outside. Cardboard treated with fire-retardants will be sufficiently fire-resistant to meet the fire code requirements for small buildings (EW30). Honeycomb panels can be filled with cellulose thermal fibres to achieve a U-factor of up to 0.21 W/m²K, which makes the units energy-efficient and reduces the operational costs. Thanks to the small size and low weight of the panels, the units can be erected by two persons using only very basic equipment. The FLe2XARD panels are fixed to the frame in a way that allows users to replace or remove them anytime, which makes the concept highly flexible.

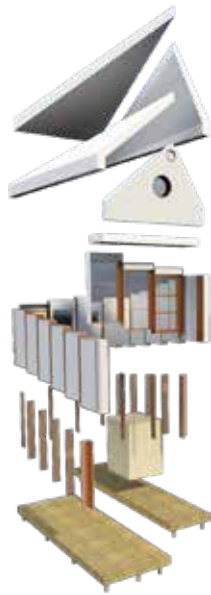

FIGURE 7.52 e³ exploded geometry



FIGURE 7.53 e³ axonometric view

Depending on the amount of space available, the houses can be placed between existing buildings or grouped together in bigger constellations. Two possible arrangements of several houses are proposed: a 'nest' for smaller groups of fifty people (E50) or a compound for up to five hundred people (E500). It is advisable to place the houses in such a way that they form a courtyard, a place to meet and undertake activities together. This will increase the community spirit among the people living in the group.

Once the houses are no longer needed, they can be easily dismantled and recycled. The FLe2XARD can be (re)used for housing people such as refugees, students, holiday-makers or festival attendees. The system can also be applied to weekend cabins at campsites or in garden plots.



FIGURE 7.54 E⁵⁰ spatial layout for 50 people

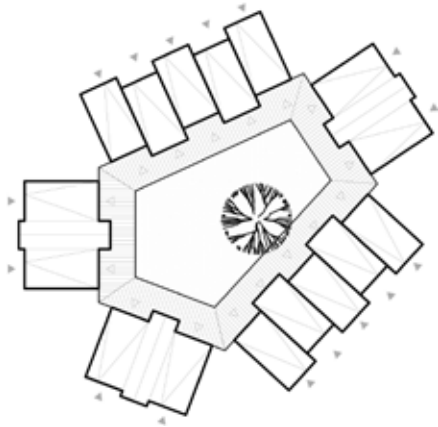

FIGURE 7.55 E⁵⁰ spatial layout for 50 people

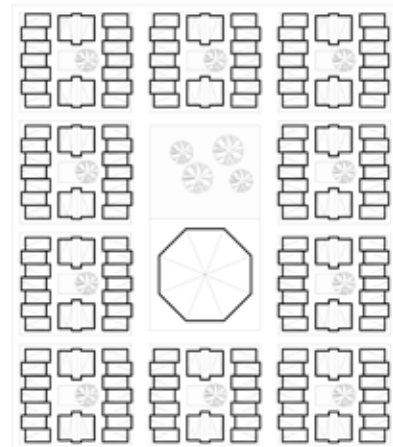

FIGURE 7.56 E⁵⁰⁰ spatial layout for 500 people

§ 7.5.3 Technical and material solutions

The building process of TECH 03 was divided into several phases, and some parts were prepared simultaneously. A team of ten students was involved in the preparation and the constructions work. The building consisted of several types of components: a floor with feet, a frame structure, wall and roof panels, and a front wall.

The floor and feet were prepared as one component made out of timber. Timber beams measuring 14 x 14cm were screwed together and formed a base frame. 14 feet made out of timber blocks measuring 14 x 14cm were screwed to the bottom of the frame. Inside the base frame were intermediate planks designed to support 18mm plywood floor panels. The base frame and wall and the roof frame system were connected to each other by means of 18mm plywood board. This board also protected the wall panels from damage at the floor level, e.g. damage caused by the impact of kicks, balls, etc. The floor panels were able to be opened to facilitate installation of water supply and sewage.

The frame structure of TECH 03 was made of paperboard L-shapes. Two of them were glued together to form a T-shaped beam or pillar. The pillars were erected on the base frame beams and were connected by an 18mm board at the base. Screw connections helped keep the base board, T-shaped pillar and wall panel together at the bottom.

The connectors between the pillars and rafters were made of wood. The flanges of the T-shaped pillars and rafters were encased by double-layered plywood joints and bolted in place. A similar connection was used between the rafters. The frame was connected to the wall panels by means of wood screws. All the connections were preset and the holes in the frame structure were made prior to impregnation.

The wall and roof panels consisted of three laminated honeycomb cardboard panels 50 mm thick. The panels came in a standard size, 1200x 2400mm, and did not need a size adjustment, which meant that very little material was wasted. The outer and inner panels were coated on one side with polyethylene film. The other sides were covered with 300 g/m² Kraftliner paper. The middle panel was covered with Kraftliner paper on both sides to improve the performance of the lamination.

The roof panels were cut at a certain angle to ensure that they fit at the top of the roof and at the connection with the walls.

The front wall consisted of a cardboard frame and a polycarbonate window and door. The frame was connected with the intermediate base beam by means of 18mm board.

The polycarbonate panel was connected to the frame with screws. The door was made out of 6mm plywood filled with one 50mm honeycomb panel.

The windows consisted of a frame made of paper tubes, Plexiglas and timber joinery. The paper tubes, whose dimensions were 200mm, 400mm and 700mm, were specially impregnated.



FIGURE 7.57 Floor component



FIGURE 7.58 Frame structure



FIGURE 7.59 T-shape pillars consisting of two L-shapes laminated together



FIGURE 7.60 Timber connectors between pillars and rafters



FIGURE 7.61 Wall panel



FIGURE 7.62 Window frame

§ 7.5.4 Prototyping

The prototype of TECH 03 was built during the Summer School of Architecture Living Unit in 2016. The theme of the Summer School referred to the need for emergency shelters that can be easily transported and can serve homeless people, victims of natural disasters and forcibly displaced people. In addition to the House of Cards, four prototypes of shelters were built. More information about the Summer School can be found on www.ssa.pwr.edu.pl.

The realised prototype of the House of Cards is the smallest unit of the Flexard system. The usable area of the house is 12m², plus a veranda measuring 2.3 m². A prototype was built and exhibited in the Wroclaw city centre in Poland. Later the unit was moved to the campus of Wroclaw University of Science and Technology's Faculty of Architecture for further testing.

The unit was prefabricated in a production hall. The partially assembled structure was then transported to the Wroclaw city centre, where the roof structure and panels were installed.

The House of Cards is powered with photovoltaic panels and lit by means of LEDs. Its battery allows it to use lights for up to 48 hours in bad weather conditions.

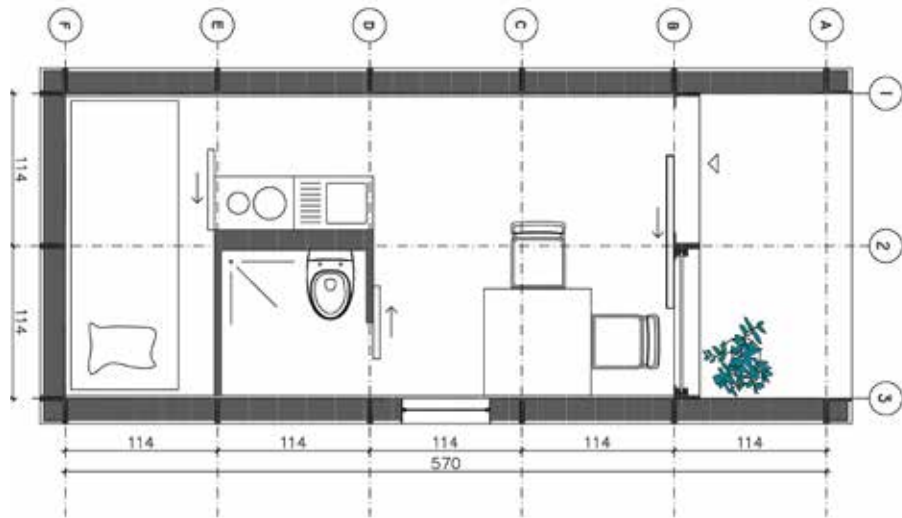

FIGURE 7.63 The House of Cards prototype plan



FIGURE 7.64 The House of Cards section and FV installation



FIGURE 7.65 Construction of the prototype



FIGURE 7.66 Construction of prototype- wall with large window

Impregnation

Two different ways of impregnation were used in the TECH 03 prototype. The first was coating the structural frame elements. The second was laminating the wall and roof panels with PVC foil. The honeycomb cardboard panels which constituted the wall and roof panels were additionally coated with polyethylene film during production of the facing layer. Frame elements made of full board L-shapes laminated together were painted with polyurethane varnish on the outside (the side that was in direct contact with the wall panels) and were painted with a lighter type of paint normally used to impregnate concrete elements. The products were suggested by the partner of the project company, PPG. For additional impregnation, the outer edges of those paper tubes that were used as a window frame and the ends of the T-shaped beams were coated with a product which turned into a thick rubber layer after application.



FIGURE 7.67 Impregnated window frames



FIGURE 7.68 Impregnated T-shaped structural frame elements

The house was ventilated by means of a ventilation grid placed at the high point of the rear gable wall and the gap under the door in the opposite wall. There was one window that could be opened. The power installation was composed of three photovoltaic panels, a battery and LEDs.



FIGURE 7.69 the House of Cards on campus of Faculty of Architecture, Wroclaw University of Science and Technology



FIGURE 7.70 the House of Cards at Solny Square



FIGURE 7.71 Night view



FIGURE 7.72 Interior of the House of Cards



FIGURE 7.73 Side wall



FIGURE 7.74 Top view on the House of Cards, Wrocław 2016

§ 7.5.5 Evaluation

The prototype of TECH 03 was built in a production hall, then transported by a low-bench truck to Solny Square in Wrocław, where it was exhibited there for two weeks. Afterwards it was transported to the campus of the Faculty of Architecture.

After one year's worth of exposure to natural conditions, the structure remains stable. It was subjected to strong winds, rain and snow, as well as to low and high temperatures. Between 10 October 2016 and 10 October 2017, the most extreme weather conditions recorded in Wrocław were as follows: [10]

- The lowest temperatures were -10°C in January and -5°C in February.
- The highest temperatures were 34°C in July and 36°C in August.
- The strongest winds measured were 60km/h in November, 65 km/h in January and 65 km/h in the first half of October 2017.
- The highest level of relative humidity recorded was 85% in December and 90% in February and May.
- The highest rainfall level was 20mm in April and July, and 22mm in September.

Some parts of the envelope of the building were slightly damaged by the rain and high humidity. The windows frames and the adjacent parts of the wall panels, in particular, were soaked. The structural frame seems to be intact and together with the wall and roof panels, it remains a stable system. The structure was left unused for an entire year, meaning there was no heating, which definitely contributed to the damage caused by the high humidity inside the building.

It can be concluded that the TECH 03 structure proved stable and suitable for natural conditions in Europe, where there is a 46-degree temperature range during the year (-10°C to 36°C) and relative humidity may be as high as 90%.

The next step will be to dismantle the structure and to recycle its parts. This will provide important information that will help us estimate the environmental impact and recyclability rate of the building.

§ 7.6 Conclusions

The various projects involved in the Transportable Emergency Cardboard House (versions nos. 1-3) presented a possible solution for emergency architecture composed of paper-based elements and components. The goal of the projects was to come up with a structural system that is suitable for emergency situations. In other words, it had to be low-cost, easy to transport and easy to build, even without specialist tools and professional construction workers. Paper-based products were used as an alternative to traditional materials such as timber, aluminium or plastics. The idea was that the building elements and components should be able to be recycled after the lifespan of the structure.

TECH was a concept for a shelter designed for victims of natural and man-made disasters and for homeless persons.

TECH 01 was designed as a replacement for the typical UNHCR family tents. The first version of the Transportable Emergency Cardboard House was designed for refugees living in the camps of northern Iraq. During the 2014-2015 winter, many locally built tents collapsed due to snowfall. TECH 01 is an emergency shelter that provides better thermal insulation and living conditions than tents. Its structure is basic and minimalist. The wall and roof panels were integrated with load-bearing frames. This reduced the construction time, but at the same time it affected the thickness and

thermal insulation of the envelope of the building. The usable area of TECH 01 is 17.4m². The costs of TECH 01 were estimated to be €5,000 at most, and its lifespan was estimated to be up to five years.

TECH 02 was a proposition for a temporary shelter or temporary house, also intended to be used in northern Iraq. The shape of the building was determined by the chosen passive-energy solutions, such as a Trombe wall, a tropical roof with a Venturi effect and an under-floor air delivery system. The usable area was 13m². The structural system consisted of T- and X-shaped beams and wall panels. After several days' exposure to the elements, the prototype was demolished and recycled. The estimated costs of this type of shelter were €10,000 to €12,000.

TECH 03 was designed as a temporary shelter or temporary house for asylum seekers, refugees and homeless people. The lifespan of the house was estimated to be five years. The structural system used in TECH 03 was called FLe2XARD and consisted of frame structure elements and wall and roof panels. The frame structure consisted of T-shapes, which were made out of two laminated L-shapes. The system was flexible and allowed designers to create different layouts, depending on the function of the shelter. The system could be used as a house for asylum seekers in asylum seeker centres or in refugee hotspots in Italy and Greece. Alternatively, it could be used as a temporary house for refugees who have been granted refugee status and are all living together in one community. Like the training house, the FLeXARD would be able to support aid organisations in their fight against homelessness. The prototype of the smallest unit of FLe2XARD system was called the House of Cards and had a usable area of 12m² plus a veranda measuring 2.3m². The estimated costs of one unit were €15,000 to €20,000.

The shape of the structures resulted from local environmental conditions. TECH 01 was a simple house with a double pitch roof at an angle of 12°. TECH 02 had a more complicated roof structure, whose shape was determined by the need for a tropical roof and the Venturi effect.

Mass-produced products produced by paper manufacturers were used in each of the TECH projects. Only the floors and joints were made of timber. The rest of the buildings was made of paper. In TECH 01 structural panels were designed. These panels incorporated a structural frame, connection elements and an insulating envelope. TECH 02 featured a wall structure made of T and X-shaped pillars and beams. The roof structure was made out of U-shapes. The wall and roof panels provided the frame structure with additional stiffness but did not carry any substantial loads. They were made out of laminated honeycomb panels and corrugated cardboard. In TECH 03 the whole frame structure was made out of T-shapes consisting of two laminated

L-shapes. The wall and roof panels were made out of laminated honeycomb panels. The combination of T-shaped pillars and beams helped eliminate thermal bridges. It also made the structure easy to understand and intuitive. All the wall panels had the same dimensions. These dimensions were identical to the standard dimensions used by the paper industry, which would have a positive effect on the price of the product. The lightweight photovoltaic panels installed in TECH 02 provided the minimal amount of energy needed to light the interior.

In order to research TECH's potential for series production, a SWOT analysis was performed.

STRENGTHS	WEAKNESSES
<ol style="list-style-type: none"> 1. readily available, low-cost, mass-produced elements 2. recycled and recyclable 3. good insulation properties 4. flexible functional arrangement 5. simple and intuitive structure 6. lightweight and limited in size 	<ol style="list-style-type: none"> 1. vulnerable to water and humidity 2. irregular quality of paper-based elements (depending on source material) 3. impregnation reduces eco-friendliness 4. limited size of the structure 5. limited lifespan
OPPORTUNITIES	THREATS
<ol style="list-style-type: none"> 1. when there is a demand for a large number of emergency shelters and houses 2. development of paper industry 3. growing environmental awareness 4. potential for commercial applications 	<ol style="list-style-type: none"> 1. competitors 2. lack of legal regulations with regard to paper as a building material 3. users have little faith in paper 4. improper use

TABLE 7.3 SWOT analysis

	O1	O2	O3	O4	T1	T2	T3	T4
S1	++	0	+	++	++	0	0	0
S2	0	0	++	++	+	0	0	0
S3	++	0	++	+	+	+	++	0
S4	++	0	0	++	+	0	0	+
S5	++	0	0	++	++	+	+	++
S6	+	0	+	++	++	0	0	++
W1	+	0	0	+	+	++	++	++
W2	++	0	0	++	+	++	++	+
W3	+	0	++	+	0	+	+	+
W4	+	0	0	++	++	++	+	0
W5	++	0	0	++	++	++	++	++

TABLE 7.4 SWOT analysis matrix

Available and low-cost material can be used for serial production of affordable shelters and housing units. These mass-produced and eco-friendly structures will definitely meet the expectations of users with a high level of environmental awareness. However, this is also to say that paper-based structures must be used for commercial applications and that the research conducted for them could also be used for further the development of emergency shelters and houses.

The high insulation properties of paper products form a strong argument in their favour, especially if TECH were to be used to replace tents. It would also reduce the consumption of operating energy and have a positive effect on people's faith in paper as a building material. The flexible layout of the units can be adapted to suit varied housing needs and can also be adapted for commercial use. Thanks to TECH's readily understood structural system, the likelihood of mistakes made on the construction site would be reduced. Add to this the fact that the system consists of lightweight building elements and components, and you have a shelter that can be erected by unskilled workers. The lightweight elements would also be easy and cheap to transport.

The downside of TECH is paper's vulnerability to water and humidity. Existing solutions such as tents and containers, made of plastics or metals, are completely watertight. This vulnerability to water will likely cause users and local authorities to have limited faith in TECH. Damage caused by TECH users may make the structure even more vulnerable.

The structural properties of paper, which are influenced by the type of pulp used and the way in which the paper is produced, can vary from product to product, and even without one product line. This makes paper a difficult material to standardise, and hence to regulate as a building material.

Due to paper's vulnerability, special impregnation of the building elements is required. Where possible, an impregnation method should be chosen that does not greatly reduce the recyclability of the building.

The above analysis shows that paper products can be used as a building material for emergency shelters and houses, as long as its limitations are respected.

The strength of the project lay in its simple structural system, which could be managed even by unskilled workers. Other strengths were the standardised building elements and components, and the building's functional flexibility. The building components were lightweight and easy to transport. However, the system may not be able to be implemented in certain countries due to a lack of legal regulations. Commercial

realisations of the concept would probably result in further research on the shelter system, which would be useful.

References:

- 1 Duppen, K., The slogan for the architectural contest project a 'Home away from home', where the FleXARD system was presented. 2016.
- 2 Refugees, U.N.H.C.f., Global Trends Forced Displacement in 2016, UNHRC, Editor. 2016, United Nations High Commissioner for Refugees Geneva, Switzerland.
- 3 OECD Affordable Housing Database. 2016 [cited 2017 28.08.2017]; Available from: <http://www.oecd.org/social/affordable-housing-database.htm>.
- 4 Eekhout, M. and ebrary Inc., Methodology for product development in architecture. 2008, IOS Press, Amsterdams. p. 230 p.
- 5 Average Male Height By Country. Available from: <http://www.averageheight.co/average-male-height-by-country>.
- 6 Architecture for Humanity, Design like you give a damn architectural responses to humanitarian crises. 2006, London: Thames & Hudson. 333 S.
- 7 Smit, M., et al., The Refugee City. 2015.
- 8 Alternative Energy Sources. [cited 2016 17.05.2016]; Available from: http://web2.mendelu.cz/af_291_projekty2/vseo/print.php?page=1071&typ=html.
- 9 Domek z kart / House of Cards. 2016 [cited 2017 23.04.2017]; Available from: <http://miastoprzyszlosci.wroclaw2016.pl/en/house-of-cards/>.
- 10 meteoblue. Archive weather records in Wroclaw, Poland. 2017 [cited 2017 26.10.2017]; Available from: https://www.meteoblue.com/pl/pogoda/prognoza/archive/wroc%C5%82aw_polska_3081368?fcstlength=1m&year=2017&month=10..