

# 5 Proto-fuse project

## Methods to boost [spatial] creativity

---

### § 5.1 Experimental approaches to derive two methods for boosting spatial creativity

---

This chapter, via two experiments, focuses on proving the hypothesis with empirical evidences. Two separate experiments were conducted under the title: The Proto-fuse project. In each of these experiments the following two concepts and their correlation with creativity have been addressed:

- 1- Conceptual blending
- 2- Tolerance of ambiguity

The experiments firstly aim to identify the relationship between conceptual blending and navigating UVEs and secondly aim to identify the importance of tolerances of ambiguity in the discipline of architecture and engineering.

The empirical evidences are published in the fourth journal article: "The Proto-Fuse project: methods to boost creativity for architects", International Journal of Design Creativity and Innovation, Taylor & Francis publisher, pp. 1-16.

## § 5.2 The Proto-Fuse Project: Methods to boost creativity for architects\*

Alireza Mahdizadeh Hakak <sup>1</sup>, Joydeep Bhattacharya <sup>2</sup>, Nimish Bilorla <sup>1</sup>, Armaghan Ahmadi Venhari <sup>3</sup>

<sup>1</sup> Faculty of Architecture, TU Delft University, Delft, The Netherlands

<sup>2</sup> Faculty of Psychology, Goldsmiths University of London, London, United Kingdom

<sup>3</sup> Faculty of Architecture, Shahid Beheshti University of Iran, Tehran, Iran

**Abstract.** Human civilization can be ameliorated by human creativity. Innovation and progress of human civilization results from a change in our thinking patterns, thus, potentially transforming the present into a creative future. Accentuating the role of creativity in design even more than other disciplines pushes one to underpin the understanding of creativity as a key role player in Architecture. Furthermore by identifying the basic principles of our ingenuity/creativity, researchers might be able to enhance this ability in the future.

The digital era allows for a new domain of architectural experience. It is assumed that new designs in virtual environments can be created that go beyond the mere accommodation of literal functions, and affect human experiences. This paper presents the role of a method developed by the authors: 'Proto-Fuse', experimented with, as an artwork for the survey of cognitive perception of humans, specifically targeting enhancement of spatial creativity. The logic behind this method is based on two psychological concepts: 1- Conceptual blending, 2-Tolerance of ambiguity. Two experimental projects were conducted for exploring the Proto Fuse method: a. "Unconventional Virtual Environments (UVEs)" to improve conceptual blending and b. "Extracting local distance" to enhance tolerance of ambiguity.

The paper concludes with an implementation scenario of the Proto-Fuse method in the pedagogy of architecture and elaborates on the results of the projects and analysis of the feedbacks received during the project session.

**Keywords.** Creativity; Architecture; Pedagogy; Education; Conceptual Blending

---

\* Published as: Mahdizadeh Hakak A., Bhattacharya J., Bilorla N., Ahmadi Venhari A., (2015), "The Proto-Fuse project: methods to boost creativity for architects", International Journal of Design Creativity and Innovation, Taylor & Francis publisher, pp. 1-16

## § 5.2.1 Introduction

---

Creative potential of human spearheads their civilization. In fact, progress at every sphere of our lives crucially depends on our creativity. Emphasizing the role of creativity in design even more than other disciplines pushes one to underpin the understanding of creativity as a key role player in Architecture. Furthermore by identifying the basic principles of our ingenuity/creativity, researchers might be able to enhance these abilities in future.

But how can we define creativity? Though creativity is the hallmark of human cognition, and therefore a topic of enormous scientific importance, yet not a single definition of creativity exists that is universally accepted by creativity researchers, and the scenario hasn't changed much in the last fifty years (Runco, 2004). Nevertheless, any creative output (be it an idea, product, or performance) should have, at least, three characteristics: novelty (it is original), usefulness (it is functional and adaptive), and surprising (it is non-obvious, therefore eliciting an aesthetical or affective response) (Simonton, 1999).

The current study focuses on 'experience', its way of operation and points out its existence and relevance in creativity. Experiences indirectly affect creativity. The larger the inventory of experiences, the more and better combination of ideas is possible. Further, the more diverse and unusual the experiences are, the higher the likelihood of creativity. For example, recent research suggests a link between multicultural experiences (e.g., learning a new language, multicultural exposure) and creative thinking (Maddux & Galinsky, 2009). The exposure to and engagement with unusual experiences and/or situations may lead to a better cognitive flexibility by breaking the fixed cognitive patterns, a source of functional fixedness, and thereby, promotes creative associations between remote or distant ideas. In fact, a recent research shows that after actively experiencing unusual virtual scenarios participants score higher on unusual use tasks, a widely applied measure of (divergent) creativity (Guilford, 1967), leading the authors to suggest a causal role of unusual and unexpected experiences in creativity (Ritter et al., 2012). Therefore, in this paper we attempt to extrapolate and connect this concept of "variety and extensiveness of experiences" to the discipline of architecture and apply it to a pedagogy of architecture as a practical creativity enhancing application.

Many architects confess that, very gradually and unconsciously they tend to stock in some conventional design approaches, because slowly confinements in construction and conventional stereotypes and rules of the physical world impose on them, dominate them and prevent them from thinking innovatively.

Considering this context, in the paper, two methods are proposed to boost creativity and reverse the process of losing it.

## § 5.2.2 Where do creative ideas come from?

As mentioned earlier, a necessary condition of creativity is the novelty aspect: a creative product or idea should not exist previously in the same form; but how can we get new ideas? In his book “The AHA! Moment” David Jones takes a bold stance by claiming that we cannot have a truly new idea, the best we can do is to make combinations of different ideas already known to us (Jones, 2012). Therefore one needs a vast subconscious mass of remembered data in order to increase the likelihood of combination of ideas.

Jones’ theory is based on a three-tiered model of human mental structure. In the following spaces, we outline briefly the salient features of this model (figure 5.1).

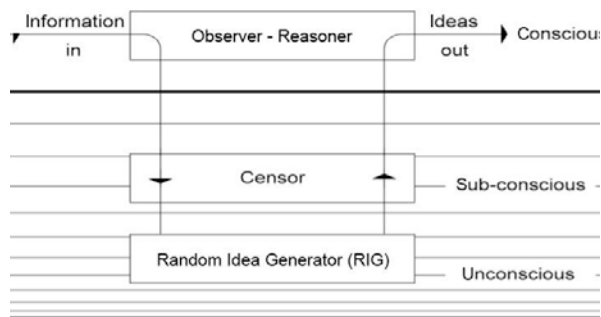

**FIGURE 5.1** The three layered model of human mental structure after Jones (2012). In this model, the upper layer, Observer-Reasoner, is in the conscious mind, the middle layer, Censor, is in the subconscious mind, and the lower layer, Random Idea Generator, is in the unconscious mind. The horizontal lines schematically depict ideas/representations and the bold line demarcates the consciousness.

The top level is the Observer-Reasoner, the conscious part of our mind that is involved with planning, execution and action. It is also involved with reasoning, argument and conscious deliberation. In short, it processes incoming data gathered from the senses and from the lower levels, critically evaluates the ideas and formed representations, and finally plans our subsequent actions.

The mid-level is the Censor, the subconscious part that houses our implicit knowledge (e.g., procedural skills, linguistic skills). It allows rapid access of stored knowledge or information. For example, our language related skills are subconscious and we can constantly access our relevant knowledge from the subconscious during writing or speaking without much delay. The Censor also protects the Observer-Reasoner from constant perturbations by preventing non-sensical absurd or uninformative ideas reaching the uppermost level. Therefore, if it is too restrictive, it impairs creativity, and if it is too permissive, the Observer-Reasoner will be flooded with meaningless ideas. The lowermost level is the unconscious mind, the creative part of it is termed as the Random-Idea-Generator (RIG) that combines randomly, without any rule/supervision, ideas or information stored in the unconscious and preconscious mind. Due to the inherent randomness in the combinatorial process, most of the RIG ideas are wrong or not functionally useful and therefore blocked by the Censor before it can reach the uppermost conscious level, the Reason-Observer. For a simple problem (such as arranging the books on a shelf), the RIG generates ideas almost on demand and pushes them up as quickly as the Observer-Reasoner can evaluate them. But for a complex problem (such as designing an office complex), the whole process may take for years. And once a creative RIG idea manages to pass the Censor and finally reaches the conscious level, it is likely to be perceived as a flash of sudden insight, known as Aha! It is to be noted that the RIG is rather immune from influences of the intellectual critical self, rather is strongly tied with the emotional self. Jones (Jones, 2012, Chapter 3) has listed various factors (such as time, expertise, social skills, gender) that interact with the RIG.

The role of unconscious processing of information in creativity is widely known. For example, in Wallas four-stage description of creative process (Wallas, 1926), the second stage is incubation, the time period during which the unconscious mental processes are active; it is also claimed that during incubation “associative processes are at work and are free from the censorship of the conscious mind” (Runco, 2014). However, this does not mean that the mental information processing below the level of conscious awareness is passive, and in fact, they can be active and goal driven (Ritter & Dijksterhuis, 2014). Recently, a possible candidate mechanism is proposed by which the transition from preconscious to conscious creativity is managed (Wiggins & Bhattacharya, 2014).

This mental model, though quite appealing due to its inherent simplicity, does not provide much insight into how ideas are combined. Even for a random combination to occur by the RIG, there has to be a mapping procedure by which ideas or concepts belonging to different domains or disciplines are allowed to merge with each other. The theory of ‘conceptual blending’ provides such

a mechanism (Turner, 1998). In his book “The Literary Mind” Mark Turner states: “Conceptual blending is a fundamental instrument of the everyday mind, used in our basic construal of all our realities, from the social to the scientific.” The theory posits that elements and vital relations from diverse scenarios are “blended” into a subconscious process known as Conceptual Blending (Fauconnier & Turner, 2008) which is assumed to be ubiquitous to everyday thought, language, metaphor and reasoning. If two concepts are similar, a simpler strategy is used to combine them and the resultant concept is less novel and offers limited surprise. However, for very different or remote concepts, complex strategies of structural mapping are required to fuse them, resulting in most novel, innovative concepts. The more mutually remote the concepts are, the more surprising and creative the blended concept is. Indeed one of the classical laboratory tests on (convergent) creativity is termed as remote associate test, which is based on this very idea that creativity involves remote associations between concepts (Mednick, 1962); see (Pereira & Cardoso, 2002) for a computational framework relating conceptual blending to convergent creative processes.

Insights obtained from these blends constitute the products of creative thinking. Arthur Koestler, championed this idea in his 1964 book *The Act of Creation* and identified a common pattern in creative achievements in art, science and humour, which he called “bisociation” (Koestler, 1964). After analysing and comparing varied instances of inventions and discoveries he concluded that fusing two unrelated elements coming from two different ideas/categories can be seen in an evolving matrix of meaning by way of a process applying analogies, comparisons, abstraction and metaphors. Indeed throughout history there are many examples of creative individuals who possessed expertise in multiple professions, thereby allowing the successful combination and cross-fertilization between different disciplines (Johansson, 2004); see also (Dubitzky, Kötter, Schmidt, & Berthold, 2012) for a recent attempt on the computational implementation of bisociation in creativity.

So far we can assume that creativity is about blending concepts, however, we can blend the ideas in different ways, and different modes of thinking, that lead us to two different types of creativity.

### § 5.2.3 Types of creativity

---

Boden has suggested two broad types of creativity: improbableist and impossibilist (M. A. Boden, 1994). The improbableist creativity involves new

or unlikely, therefore improbable in nature, combinations of existing ideas, which is similar to the earlier concept discussed by David Jones. This is also the current working definition of creativity in architecture. Though this is not a universally accepted definition of creativity, however, informally this is the usual creative process, which architects follow. On the other hand, the impossibilist creativity is a deeper type involving the mapping, exploration and transformation of conceptual spaces. Therefore the two types differ in the mode of the creative thinking. Improbabilist creativity specifies thinking in the associative mode, while respecting the logics, (physical) rules, and boundaries and constraints. If we extrapolate this definition to architecture, obeying conventional rules and the role of confinements in architecture in terms of material, technology, even perception of new spaces become clear. Impossibilist creativity involves the spontaneous generation of new states with new properties. Gabora provides a mathematical description of impossibilist creativity using an example of a torch (Gabora & Aerts, 2002). This example involves the spontaneous appearance of a new state (the state of mind that conceives of the torch) with a new property (the property of being able to move fire). Impossibilist creativity is subject to the bisociative mode, in which the conceptual space is transformed, possibly at the expense of existing rules and disciplinary boundaries, and therefore affords higher autonomy in the procedure (Koestler, 1964). It is literally presumed that a product of impossibilist creativity needs mutation and transformation of the corresponding conceptual spaces (M. Boden, 1995). Impossibilist creativity in architecture can be associated with ignoring the physical rules (e.g. gravity), ignoring structured Euclidean geometry and move to non-Euclidean fluidity, while creatively distorting and blending scale, material limitations and essentially reverse engineering the very act of conceiving space etc.

The first step relevant for creativity in design is quintessentially an enhancement of the perception of spaces itself. Since our visual perception is overly used to (and therefore constrained by) the environment around us in term of scale, depth, dimension, etc., changing the characteristics of the conventional environment around us might pave the way towards transformation of the corresponding conceptual spaces.

#### § 5.2.4 Shifting to Impossibilist conceptual blending in architecture

---

In the same logical vein as above, we expect to find similar outcome in the architecture discipline in design processes. The question here is how we transform improbabilist creativity to impossibilist creativity in architecture.

Since the information feed of the brain is limited to what has been provided by the senses (e.g., hearing, seeing, touch), the experiences that can be accumulated from experiencing the physical world are limited or constrained by the environment around us, in terms of its scale, depth, dimension, etc. Transformation of the corresponding conceptual space needs mutation that seems farfetched with the available information feed. Therefore changing the characteristics of the conventional environment around us may provide an alternative route for transformation of the corresponding conceptual space.

The digital era allows for new possibilities of architectural experience. It is assumed that new designs in virtual environments can be created that go beyond the mere accommodation of literal functions, and that affect human experiences. Detached from the real one in sense of time and matter, they enable the designers to cross the boundary between reality and fiction, thus expanding their inventory. This new kind of architecture can create emotionally rich architectural experiences through dynamic and precise manipulation of abstract visual forms in virtual space.

Unconventional Virtual Environments (UVEs) can be designed, within which, spatial patterns can dynamically evolve in time with respect to user interactions. A variety of spatially intriguing concepts such as: Multiple dimensions, Dematerialization, Infinite depth, Continuous change, Multiple scales etc. can thus be experimented with. These concepts and their visualization can render cognition and perception a new meaning owing to the fact that the brain has not experienced and comprehended such concepts before and is thus not pre-conditioned to interpret them (Figure 2).

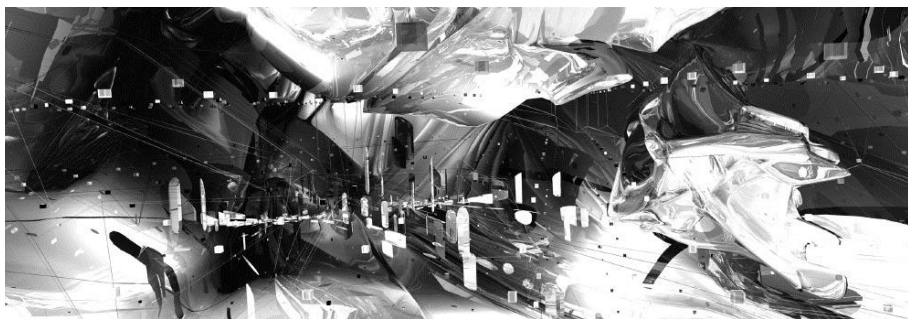

FIGURE 5.2 V4D\_Visio4D by Marcos Novak

In this stage the inventory of experiences is constantly expanding and we can expect by blending new data with the old ones mutations are bound to happen.



From a cognitive point of view extensiveness of experience gained by surfing in unconventional virtual environments can positively be related to both creative performance (enhance interactivity, lateral thinking, idea generation, etc.) and creativity-supporting cognitive processes (retrieval of unconventional knowledge, recruitment of ideas from unconfined virtual environment for creative idea expansion). Eventually with new languages and forms we can stimulate our creativity (Bartle, 2004).

### § 5.2.5 The Relationship between Tolerance of Ambiguity and Creativity

---

A substantial body of literature suggests a possible link between tolerance of ambiguity and creativity. A creative individual should have the ability, will and desire to deal with ambiguous and open-ended situations and suspend his/her immediate judgments to allow various possibilities to emerge (GOLANN, 1962; Stoycheva, 2003). Taylor and Barton listed a liking for abstraction with considerable tolerance of (cognitive) ambiguity as one of the key traits of a creative scientists (Taylor & Barron, 1963). A positive correlation was indeed observed between the tolerance of ambiguity scale and certain measure of creativity (Tegano, 1990). In fact, an influential model of creativity, the investment approach, has considered the tolerance of ambiguity as one of the most crucial attributes of creative personality (Lubart & Sternberg, 1995). Amabile illustrates the judgment suspension as “keeping response option open as long as possible” as well as tendency to break down the conventional rules/methods whenever necessary (Amabile, 1996). Intrinsic motivation is also connected to creative achievements (Hennessey & Amabile, 1998). We argue here that tolerance of ambiguity is related to creativity because it “empowers the intrinsically motivated exploration of novel, unusual, or complex stimuli” (Zenasni, Besançon, & Lubart, 2008). Barron and Harrington show that creative achievers tend to be attracted towards complexity (Barron & Harrington, 1981). Dacey describes as: “The first characteristic of the creative person is tolerance of incongruity, which could be called tolerance of ambiguity (Dacey, 1989). Its opposite could be called fear of the unknown or unfamiliar.” Eysenck illustrates that highly creative individuals, “can live with doubt and uncertainty, even enjoying risks and seeking out instabilities in the world” (Eysenck, 1993).

Amabile also emphasizes the ability of divergent thinking and using wide and flexible categories (Amabile, 1996). Individuals, who cannot tolerate ambiguity, tend to seek the solution through available options and rigid categories and tend to close the situation prematurely (Kenny & Ginsberg, 1958). However one

should not confuse creativity with intelligence, as Kenny and Ginsberg found that individuals with high levels of intelligence but low levels of creativity tended to be “intolerant of unlikely, unconventional types of hypothesizing about the world” (Kenny & Ginsberg, 1958).

These literatures altogether conspicuously suggest a positive association between creativity and tolerance of ambiguity (Taylor & Barron, 1963) .

## § 5.2.6 Implementation in “pedagogy” of architecture

---

Referring back to the human mental structure as proposed by David Jones (Figure 1), we consider the model to be quite appropriate for designers, especially considering the supposed role of unconscious RIG in generating creative ideas and concept. Design thinking uses more of tacit knowledge of the unconscious mind rather than explicit knowledge of the conscious mind. A physical metaphor will be an iceberg, the small portion outside the water representing the conscious mind, the big submerged part represents the unconscious mind and the surface of the water is the censor line. It is immediately obvious that the capacities are not comparable: the unconscious mind is vastly superior in terms of information processing capacity therefore the capacity limitation of the conscious mind slows down the mind’s performance in complex, multi parameter based processing with a large number of constraints.

Problem solving procedure in architecture also involves many stakeholders from other disciplines: structural engineering, mechanical/electrical issues, energy saving, material properties, cost efficiency, social aspects of the inhabitants, interaction with the context, neighborhood and city and so forth, therefore dealing with all aspects of the design at the same time makes the mind rather confused, much sooner. However the unconscious mind has a large capacity to incorporate these aspects in mind and find a proper solution. Designers are trained to harness the tacit knowledge of the unconscious, instead of the explicit knowledge of the conscious mind. This ability helps architects to relate and optimize multiple parameters and find apt solutions that meet their requirements. Meanwhile, this also entails the inability to rationalize the design process in a fully explainable manner, since many of the solutions are discerned from an “Aha! Moment”, and are thus not describable.

## § 5.2.7 Proto-Fuse method

---

Summarizing, the aforementioned context, we can effectively extract two important parameters pertinent to creativity:

- Conceptual blending and impossibilist creativity
- Tolerance of ambiguity

This paper elaborates the role the Proto-Fuse method, tested as an artwork for the survey of cognitive perception of humans, targeting the enhancement of spatial creativity. Simply put, it can be considered as a method of transiently altering our visual environment in order to promote two critical functions: (i) a mutation in unconscious and (hypothetical) RIG (see Figure 1), and (ii) improvement of tolerance of ambiguity, with the final aim to enhance creativity.

The recent propagation of inexpensive, at hand, high performance computing is driving scientists to generate larger, more complex data sets from the simulations they develop. This can also be said of modern artworks that take place in virtual environments, where the audience can manipulate, and explore it interactively. We find this approach appropriate to extend human experience/perception of space. It is designed for the purpose of gaining insight and developing intuition about environments in which the brain cannot venture because of constraints of the physical world: N-dimensional information spaces, the worlds of the very small or very large, from nanotechnology to cosmology, from neurophysiology to new media, even imaginary virtual worlds in which the characteristics of physical world are not dominant e.g. zero gravity or continuous change.

The paper focuses on this method to blend new ideas in the unconscious mind following the idea of conceptual blending and expects mutation in random idea generation (RIG), which subsequently will help to shift from improbableist creativity to impossibilist creativity. For reaching this aim two approaches are proposed and explained:

- Navigating in UVEs (helping conceptual blending mutation)
- Extracts of local distance (helping tolerance of ambiguity)

### § 5.2.7.1 Navigating in Unconventional Virtual Environments (UVEs)

---

Art is unhindered by the strict practicalities that result from purely scientific pursuits and thus makes a good test bed for experiencing some qualities that do not exist in rule-based physical universe. Art is firmly embedded in the history of immersive virtual reality spaces. Indeed, Cave Automated Virtual Environments (CAVEs) are now an established medium for artists. CAVEs provide a space where art can be dynamic, interactive, immersive, and multimodal.

The Chair of Hyperbody at the TU Delft previously conceived such a space: The Virtual Operation Room as a future self-diagnostic tool and auto-curing health game. The goal is to locate and exterminate cancerous cells, thus healing the patient embodied in the avatar. This virtual environment was developed for an exhibition at the Delft Museum of Technology. Actual architectural concepts like e-motive architecture, time-based architecture, programmable architecture, freeform styling, coupled with computational techniques involving complexity sciences (swarm behavior and genetic algorithms) come together in UVEs. The science of virtual reality has contributed to the world of art; however, the contribution of art to the science of virtual reality and the development of the software and hardware infrastructure of these spaces has received little attention. Virtual reality artworks often challenge the capabilities of the spaces in which they are installed. Since no specific software system or interactive design was in place for the target of Proto-Fusion, there was ample opportunity to allow the art to drive the technological design (figures 5.3,5,4).



FIGURE 5.3 UVEs by authors

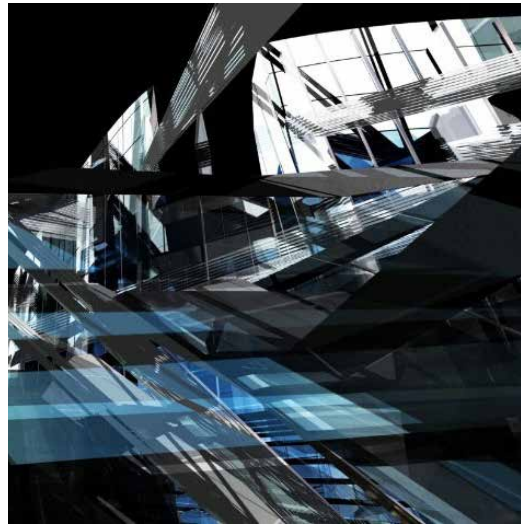

FIGURE 5.4 UVEs by authors

## § 5.2.7.2 Extracts of Local Distance

---

“FELD - studio for digital crafts” initiated a project named “Extracts Of Local Distance”. In collaboration with the studio, we used this project as a test bench for experimenting tolerance of ambiguity through a group of participants. The description of the project borrowed from their website (<http://www.localdistance.org/process.php#process>) is as follows:



FIGURE 5.5 Extracts Of Local Distance Project (used with permission)

“There is a strong bias regarding image composition in architecture photographs. Perspective foreshortening and vanishing lines dominate the overall impression of the image. This realization lead to experiments in automated extraction of said features in the image data. The medium used for the result is just one of the many possibilities. The method also bears the potential for further experimentation and can be considered a work in progress.

Countless fragments of existing architectural photography are merged into multi-layered shapes. The resulting collages introduce a third abstract point of view next to the original ones of architect and photographer. Digital scans of analogue architectural photography form tiny pieces of a large resulting puzzle. The original pictures are being analyzed and categorized according to their vanishing points and shapes. Based on this analysis, slices are being extracted from the source image. These slices retain the information of their position corresponding to their original vanishing point and thus form a large pool of pieces, ready to be applied to new perspectives and shapes.

Using the extracted image segments, it is now possible to form collages of originally different pictures with a new common perspective. In order to compose a collage, a perspective-grid is defined and a lining of matching image segments is being applied. The segments are not altered to match the frame but fitting ones are chosen from the sheer mass of possible pieces. By defining additional keywords that describe the content of the original photographs, the selection of segments used for the final composition can be influenced. Thus a contextual layer is added through the semantic linking with the source material. The resulting fine-art prints are entirely unique each time."

To see the impact of these images on different groups of participants, a small experiment was designed. A crowd sourcing method was used for this experiment. An interface with clear instructions was designed, and students were asked to participate in the experiment via social networking sites. The instructions were spread and shared by people using Facebook and participants were asked to send their response as a private message, to avoid being influenced by other respondents. More than 130 different feedbacks were collected in one week and we stopped collecting data afterwards. Since more than 80 percent of the participants were from Architecture/Engineering background and to specify more the target of the experiment was aiming to narrow down the target groups as much as possible, we decided to remove about 20% of the responses from people who were from disciplines other than architecture and engineering (medicine, law, chemistry, literature, etc.). Eventually, 102 participants were chosen and were distributed in groups of two students, one from Architecture and one from Engineering.

The groups were asked to give their feedback about their immediate feeling after watching a series of images that were taken from "Extracts Of Local Distance Project". Proportion of the participants in terms of male and female was almost the same (53 female and 49 male) and the average age of the group was 26 years (from 18 to 36). Responses obtained from some of the participants are shown below (table 5.1):

1	M	Architect	A science-fiction feeling. Sounds ridiculous, but I see it as a dream where you can choose whatever you desire, a puzzle that you can create with whatever you like out of the assemblage
2	F	Architect	It's a mess, A tornado passed by a room and created chaos. I feel speed, like watching from the window of a moving train. The lack of logical connection between elements is because of motion. It is not a static still image, it is moving....
3	F	Engineer	I can say my opinion in some words: Perspective, order, disorder, technology, future, earth, loneliness...
4	M	Engineer	The picture is fragmented, does not give me any special feeling. I do not hate it; I do not like it though.
5	F	Architect	On the first look it give me a headache, stress and rush and I do not want to stay there anymore. On the second look though, I can see layers and layers beneath. Each time I am exploring something new. I enjoy exploring...
6	M	Architect	I enjoy ambiguous environments, especially those that engage the brain and stimulate it.
7	M	Engineer	I am not patient to dig in the image and explore them. I cannot stand them.
8	F	Architect	I use a lot of collage and sketches in my designs; I love to be a journalist architect....
9	F	Architect	If I had not seen the word ambiguous in the instruction, I would not consider this images as ambiguous. They are not ambiguous...
10	M	Architect	What I remember from any space I have been is like these images; they are not ambiguous.
11	M	Engineer	It is like a modern art which does not necessarily give me good feeling. I do not understand the shape of the building. The ones from inside are more interesting though.
12	M	Engineer	It is not comforting for me, especially ones with big scale, in which you lose your human scale or ones with more than one vanishing point.
13	F	Engineer	I try to find an order in the chaos, Try to find a route/way through the vanishing point...
14	F	Architect	My eyes look at different local points and create a perception, but I cannot combine them and create a holistic image. I think the more I can tolerate these local points without connecting them, I am more creative...

TABLE 5.1 Summary of comments from each participant's feedback, on "Extracting local distance project"

At first glance one notices two different approaches to define the images: convergent approach and divergent one. Mostly students with engineering background tend to simplify the image as soon as possible, following guidelines, protocol and rules to analyze the image and reach to a conclusion/perception. This might be due to a general tendency towards a lack of suspension of their judgment and finalizing their responses immediately without waiting for further deliberations; alternatively it also could be due to a lack of personal engagement with the images due to the content of the images. On the other hand, the architecture students seem to explore more through layers, dig more and find more meanings out of that. This offers preliminary

evidence supporting the fact that architecture students are more trained in terms of dealing with different parameters and variety of conditions in a design/problem solving task.

Extrapolating the same logic, we can expect that by providing new ground or visual environment for architects, we may enhance their tolerance of ambiguity, suspend their judgments and ultimately help them become more creative.

## § 5.2.8 Designing a NSA (non-standard architecture) to enhance Impossibilist creativity

---

We can start by defining what Non-Standard architecture is. Non-standard Architecture (NSA) is defined as an architecture that departs from modernist, repetitive, mass-production principles in order to address complexity, variation, and mass-customization.

To reach these qualities we can implement virtual environments within the design process. Hakak explained in a recent paper about the application of interactive unconventional virtual environment (UVEs) workshops, in which students can navigate in UVEs and gain novel experiences (Hakak, Biloria, & Rahimi, 2012). Following the same idea but with suitable extension, in a designed workshop we asked students not only to navigate in UVEs, but also to design one of them. In collaboration with Islamic Azad University, Mashhad branch, Faculty of Art and Architecture (<http://en.mshdiau.ac.ir/>), a group of twenty students were asked to transform a normal conventional building to a Non Standard Architecture, using the 3d max interface (figure 5.6). All the participants were chosen from a Bachelors class and there were 12 female and 8 male students, all of them in the age of 20-22. We chose the pool of participants from Bachelors students because they were still developing design-thinking abilities and were thus more prone to absorb novel modes of design processes.



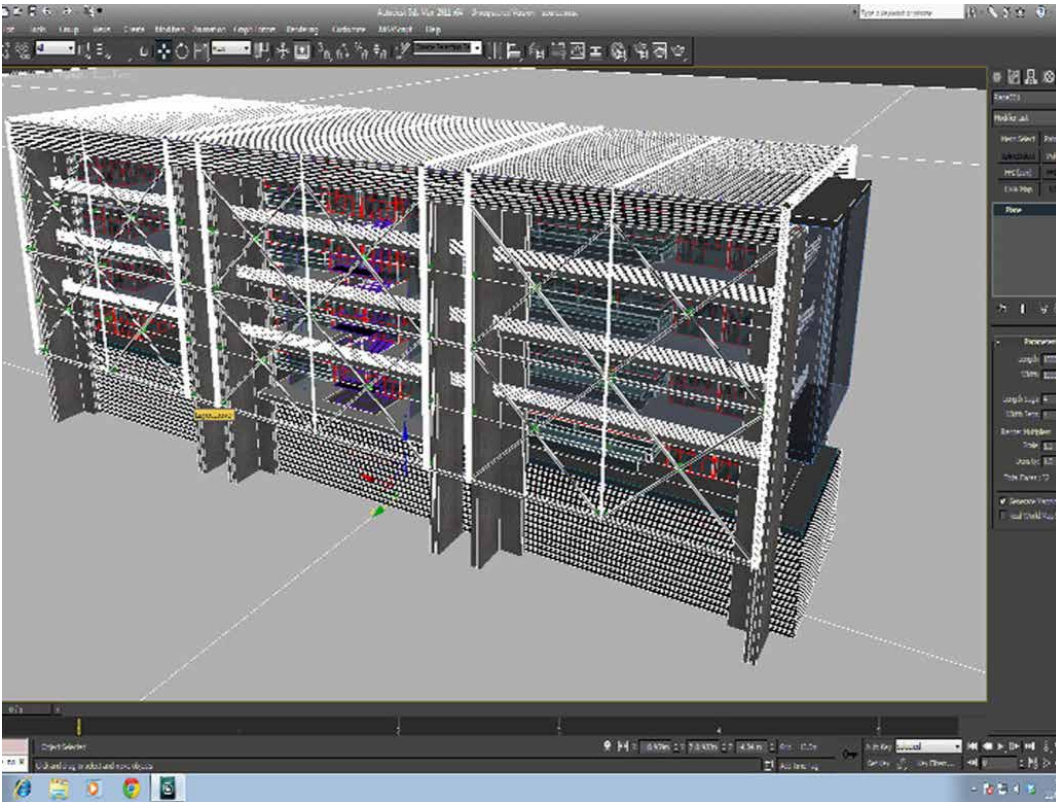

FIGURE 5.6 A normal building in 3d-max interface

The task was to use some simple commands of 3d max software (FFD box, bend, scale, etc.) and transform a conventional building (a modern repetitive, mass production design) to an unconventional (non-standard, mass customization, interactive) one, almost an alien. The definition of alien was subjective for students. Some considered a “Sci-Fi, futuristic building”, some interpret it as “what does not exist in reality” or “as weird as possible”. They were free of any confinements of the physical world, e.g. gravity, material limitation, cost, etc. (figure 5.7). Two semi-structured interviews were conducted with each participant: the first interview after the first hour of the experiment (before demonstrating any sample works of any kind), and the second interview after presenting some sample works of NSA and also after explaining the logic of conceptual blending behind the experiment.

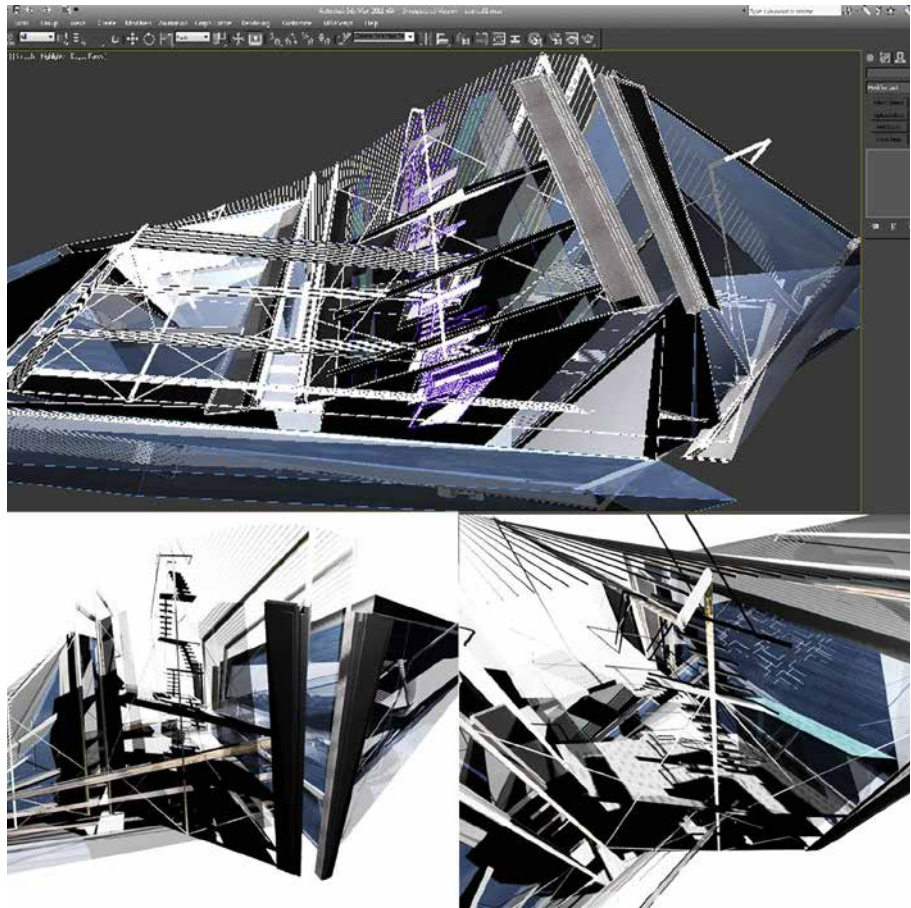

FIGURE 5.7 screenshots of transformed building, designed by students

As we expected after the first hour, students were wondering or even confused. They struggled to find where to start, what to do, potentials of discarding constrains, etc. However after explaining the logic and watching the samples they arrived at some interesting results (Tables 5.2 , 5.3).

1	Constraints help me to organize my ideas
2	Constraints give me a starting point, I do not know where to start where to go
3	Takes time to get used to this kind of design approach, I have a lot of liberty; do not know what to do though.
4	Non-sense, what is the point of this experiment? This is not Architecture
5	Unconsciously I tend to use/think in conventional methods. I do not know how to get rid of that
6	I am enjoying, the more I go further, the more I explore and enjoy
7	I am wandering
8	I need a starting point, conventionally I start with analysis of the site and get ideas from the constraints, I can not design context free
9	Confused
10	What is the point of designing something that cannot be built?

TABLE 5.2 Summary of comments from each participant's interview in the middle of experiment

1	I have to change my design approach. There is no starting point. I play with the given object and meanwhile the design appears.
2	There is no "where to go" in this project, you can stop whenever you want, there is no start and end
3	I am getting used to it, I prefer to see a lot of samples though.
4	It is architecture but not in physical world. I keep asking myself if we are going to design a future scene in a futuristic movie, who is going to design that? Director? Screenwriter? Architects should do this!
5	You have to learn to think out of the box
6	I'm getting even better!
7	When I saw the samples, I have some ideas where to go, but still I'm biased with the Images I've seen.
8	I do not dare to leave my conventional approach yet, I afraid I'd get lost in this new way of thinking
9	I am trying to get rid of conventional approaches and embrace a new method
10	Now I know it is not about building something, it is about being creative

TABLE 5.3 Summary of comments from each participant's interview after the experiment

As we can see in the tables, in the second interview, students begin to leave their conventional design approaches and think differently, they also tend to leave the conventional standards, regulations and physical rules. What we define as a conventional design approach is a Euclidian geometry in which the load transfer is through beams and columns to the foundation, angles tend to be rectangular and moreover, there are restricted rules on seismic regulations and structure of the design. Many other parameters including the sustainability, costs, exploitation comfort for residents of the building, accessibility of the materials and so forth are all parts of the conventional design approach. However, there was not any problem-solving or real architectural design task.

Referring again on the results of the workshop, we can see that students dare to leave the conventional method which they have learnt in their schools. Angles are not linear anymore, no physical constraints on the structure or materials can be seen. The cost and also possibility of construction is totally neglected. The aim of the workshop was only to train students and help them become familiar with new geometrical qualities and spatial expressions that were unknown to them. By this freedom of thought we can thus state that we initiated the very first steps towards a new method in architecture pedagogy.

## § 5.2.9 Discussion and Conclusion

---

Two different approaches have been utilized to define the images of the first experiment: Convergent and Divergent. Engineers tend to follow the convergent approach, simplify the image as soon as possible, follow guidelines, rules and converge all of them to reach to conclusion, unlike architects, who have been trained during their education to include as many parameters as possible in their design and suspend their judgment as much as possible. Architects also tend to dig more, through deeper layers and dare to suspend their judgment. The divergent approach, that they apply help them to deal with different parameters and variety of conditions in a design/problem solving task. Through this paper, the authors suggest to include “tolerance of ambiguity workshops” in the pedagogy of architecture to train them even more.

In the second experiment students learnt to leave their conventional design approaches, conventional standards, regulations and physical rules and dare to look at the task from a totally different angle. Moreover, via the experiment new unconventional feed/stimulus was provided for the unconscious mind to play with. Also, with this unconventional experiment, their inventory of experiences was expanded and we can expect that in the near future, mutations would happen in their RIG, subsequently resulting in new ideas to crop up in their minds.

To be creative we need to blend concepts, that are remotely connected and preferably unfamiliar, and this conceptual blending often occurs in our unconscious mind. To have a new blending we need mutations; combination of concepts. To reach a state of mutation, the sensory feed of the brain can be changed by something that is novel for the brain, thereby stimulating the brain to perceive the new surroundings, forging new connections between abstract representations. This idea of conceptual blending is quite relevant in

architecture as well. Improbabilist creativity can turn to impossibilist creativity by applying unconventional virtual environments to attain the mutation of ideas. In this article we thus suggest that creating a new perception of the environment itself, as the first step of architectural pedagogy will be a positive step towards expanding an educator's ideas, resulting in a transition from an improbabilist to an impossibilist mode of creativity.

Training future students of architecture to tolerate more ambiguities during their design process, by designing specific ambiguous experiences and training them gradually for more ambiguous situations, can provide a suitable springing board for implementation of the Proto-fuse concept. Providing virtual reality workshops for students, where they can navigate, interact and explore unconventional virtual environments will add new and unique opportunities to enhance their inventory of experiences, subsequently leading to novel ideas generation ability. Authors also believe that late years of the Bachelors period for students before their Masters would be a suitable time, since students are already familiar with basics, rules and regulations of the architecture discipline and with these workshops they train to think out of the box.

Students in our pilot experiment showed considerable interest and attained intriguing results at the end, thereby providing a first, though preliminary evidence of the potential of our approach in architecture pedagogy.

## References

---

- Amabile, T. M. (1996). *Creativity in context*: Westview Press.
- Barron, F., & Harrington, D. M. (1981). Creativity, intelligence, and personality. *Annual review of psychology*, 32(1), 439-476.
- Bartle, R. A. (2004). *Designing virtual worlds*: New Riders Pub.
- Boden, M. (1995). Creativity and unpredictability. *Constructions of the Mind: Artificial Intelligence and the Humanities*. *Stanford Electronic Humanities Review*, 4(2).
- Boden, M. A. (1994). *Precis of the creative mind: Myths and mechanisms*. *Behavioral and Brain Sciences*, 17(3), 519-531.
- Dacey, J. S. (1989). *Fundamentals of creative thinking*: Lexington books Lexington, MA.
- Dubitzky, W., Kötter, T., Schmidt, O., & Berthold, M. R. (2012). Towards creative information exploration based on Koestler's concept of bisociation (M. R. Berthold Ed.). *Biosociative knowledge discovery*: Springer.
- Eysenck, M. W. (1993). *Principles of cognitive psychology*: Lawrence Erlbaum Associates, Inc.
- Fauconnier, G., & Turner, M. (2008). *The way we think: Conceptual blending and the mind's hidden complexities*: Basic Books.
- Gabora, L., & Aerts, D. (2002). *Contextualizing Concepts*. Paper presented at the FLAIRS Conference.
- GOLANN, S. E. (1962). The creative motive. *Journal of personality and social psychology*, 30, 588-600.
- Guilford, J. P. (1967). *The nature of human intelligence*: McGraw-Hill.
- Hakak, A. M., Biloria, N., & Rahimi, M. R. (2012). Implementing Unconventional Virtual Environments for Enhancing Creativity in Architecture Pedagogy. *International Journal of Virtual and Personal Learning Environments (IJVPLE)*, 3(4), 41-52.
- Hennessey, B. A., & Amabile, T. M. (1998). Reality, intrinsic motivation, and creativity.

- Johansson, F. (2004). *The medici effect: Breakthrough insights at the intersection of ideas, concepts, and cultures*: Harvard Business review Press.
- Jones, D. (2012). *The Aha! Moment: A Scientist's Take on Creativity*: JHU Press.
- Kenny, D. T., & Ginsberg, R. (1958). The specificity of intolerance of ambiguity measures. *The Journal of Abnormal and Social Psychology*, 56(3), 300.
- Koestler, A. (1964). *The act of creation*: Hutchinson & Co.
- Lubart, T. I., & Sternberg, R. J. (1995). An investment approach to creativity: Theory and data. *The creative cognition approach*, 269-302.
- Maddux, W. W., & Galinsky, A. D. (2009). Cultural borders and mental barriers: the relationship between living abroad and creativity. *Journal of personality and social psychology*, 96(5), 1047.
- Mednick, S. (1962). The associative basis of the creative process. *Psychological review*, 69(3), 220.
- Pereira, F. C., & Cardoso, A. (2002). Conceptual blending and the quest for the holy creative process. Paper presented at the Workshop on Creative Systems. [en línea] <http://eden.dei.uc.pt/~camara/files/Quest-CRC.pdf>.
- Ritter, S. M., Damian, R. I., Simonton, D. K., van Baaren, R. B., Strick, M., Derks, J., & Dijksterhuis, A. (2012). Diversifying experiences enhance cognitive flexibility. *Journal of Experimental Social Psychology*, 48(4), 961-964.
- Ritter, S. M., & Dijksterhuis, A. (2014). Creativity—the unconscious foundations of the incubation period. *Frontiers in human neuroscience*, 8.
- Runco, M. A. (2004). Everyone has creative potential. *Creativity: From potential to realization*, 21-30.
- Runco, M. A. (2014). *Creativity: Theories and themes: Research, development, and practice*. Amsterdam: Elsevier.
- Simonton, D. K. (1999). *Origins of genius: Darwinian perspectives on creativity*: Oxford University Press.
- Stoycheva, K. (2003). Talent, Science and Education: How Do We Cope with Uncertainty and Ambiguities? P. CSERMELY & L. LEDERMAN (Eds), 31-43.
- Taylor, C. W., & Barron, F. E. (1963). *Scientific creativity: Its recognition and development*: John Wiley.
- Tegano, D. W. (1990). Relationship of tolerance of ambiguity and playfulness to creativity. *Psychological Reports*, 66(3), 1047-1056.
- Turner, M. (1998). *The literary mind: The origins of thought and language*: Oxford University Press.
- Wallas, G. (1926). *The art of thought*: Harcourt Brace, New York. .
- Wiggins, G. A., & Bhattacharya, J. (2014). Mind the gap: an attempt to bridge computational and neuroscientific approaches to study creativity. *Frontiers in human neuroscience*, 8.
- Zenasni, F., Besançon, M., & Lubart, T. (2008). Creativity and tolerance of ambiguity: An empirical study. *The Journal of Creative Behavior*, 42(1), 61-73.